

Friggitrice elettrica mod.FT4-44-8-88 & SF9-99

Electric fryer mod.FT4-44-8-88 & SF9-99

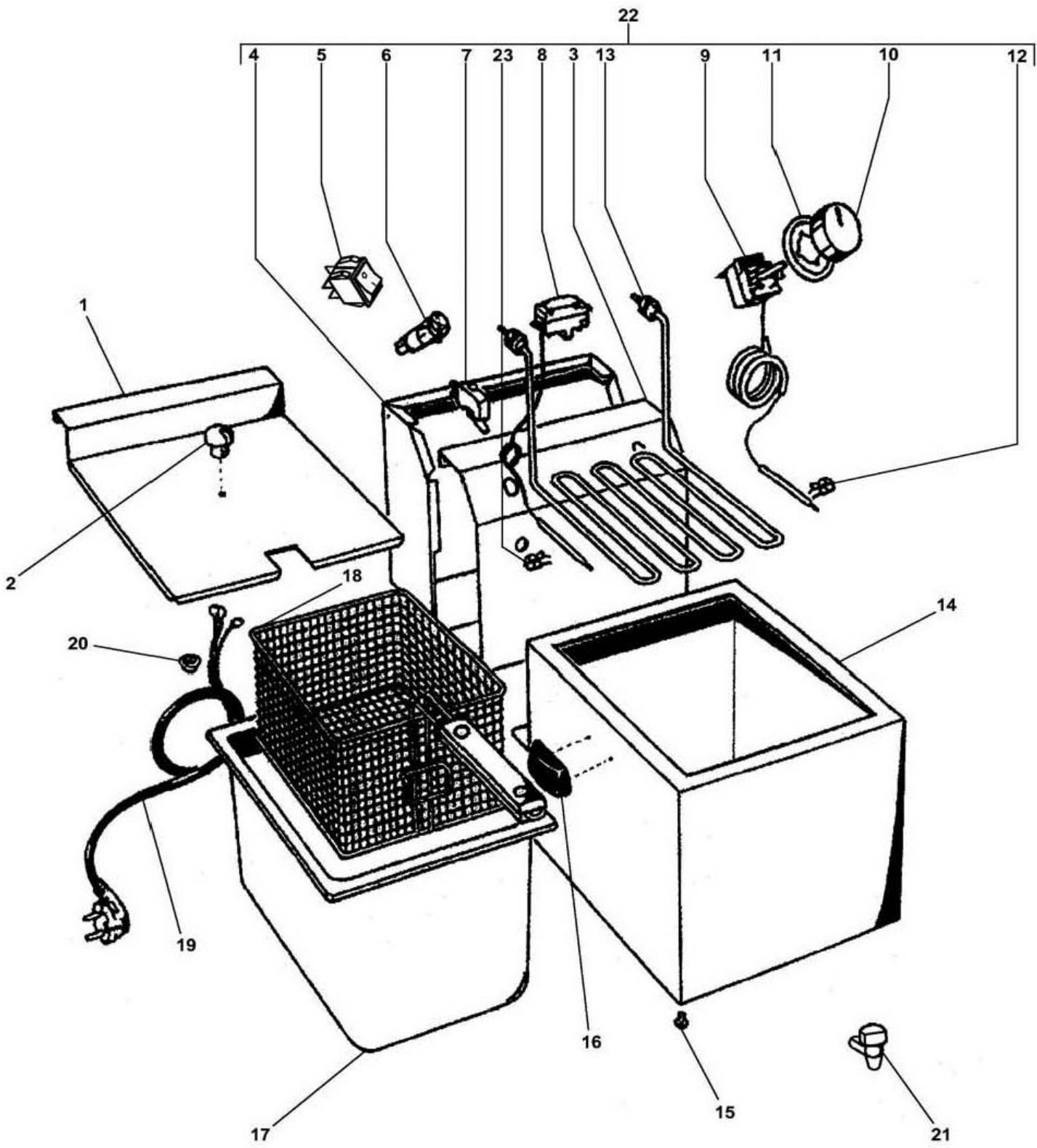

FRIGGITRICE ELETTRICA MOD.FT4-44-8-88 & SF9-99
ELECTRIC FRYER MOD.FT4-44-8-88 & SF9-99

Rif No	Codice Code	Caratteristiche Characteristics	Descrizione Description
1	CO1100	(FT4-44)	Coperchio Cover
1	CO1101	(FT8-88)	Coperchio Cover
1	CO1134	(SF9-99)	Coperchio Cover
2	CO1102		Pomello Knob
3	CO1103	(FT4-44)	Pannello Panel
3	CO1104	(FT8-88)	Pannello Panel
3	CO1140	(SF9-99)	Pannello Panel
4	CO1105	(FT4-44)	Pannello Panel
4	CO1106	(FT8-88)	Pannello Panel
4	CO1141	(SF9-99)	Pannello Panel
5	CO1038	☺	Interruttore Switch
6	CO1108	230V 2W	Lampada Lamp
7	CO1109	☺	Microinterruttore Microswitch
8	CO1110	☺	Termostato Thermostat
9	CO1111	☺	Termostato Thermostat
10	CO1112		Pomello Knob
11	CO1113		Ghiera Locking ring
12	CO1115		Clip Clip
13	CO1116	☺ 230V/1Ph/50-60Hz(FT4-44)	Resistenza Resistance
13	CO1117	☺ 230V/1Ph/50-60Hz(FT8-88/SF9-99)	Resistenza Resistance
14	CO1118	(FT4)	Carcassa Housing
14	CO1119	(FT44)	Carcassa Housing
14	CO1120	(FT8)	Carcassa Housing
14	CO1121	(FT88)	Carcassa Housing
14	CO1142	(SF9)	Carcassa Housing
14	CO1143	(SF99)	Carcassa Housing
15	CO1122		Piedino Foot
16	CO1123		Maniglia Handle
17	CO1124	(FT4-44)	Contenitore Tank
17	CO1125	(FT8-88)	Contenitore Tank
17	CO1144	(SF9-99)	Contenitore Tank
18	CO1126	(FT4-44)	Cestello Basket
18	CO1127	(FT8-88 \ SF9-99)	Cestello Basket
19	SL1671	1Ph+N+Gnd	Cavo elettrico Electric cable
20	CO1129		Pressacavo Cable clamp
21	CO1145	(SF9-99)	Rubinetto Cock
22	CO1132	(FT4-44) Assembly	Resistenza Resistance
22	CO1133	(FT8-88) Assembly	Resistenza Resistance
22	CO1139	(SF9-99) Assembly	Resistenza Resistance
23	CO1175		Clip Clip

(*): fuori produzione / out of production

☺ : ricambio consigliato / spare part suggested