

**SERVICE MANUAL  
FRYMASTER H14 SERIES  
ELECTRIC FRYER**

This equipment chapter is to be installed in the Fryer Section of the *Equipment Manual*.

**FOR YOUR SAFETY**  
Do Not Store or use gasoline or other flammable vapors and liquids in the vicinity of this or any other appliance.

**MANUFACTURED  
BY  
FRYMASTER CORPORATION  
P.O. BOX 51000  
SHREVEPORT, LOUISIANA 71135-1000  
PHONE: 1-318-865-1711  
TOLL FREE: 1-800-551-8633  
1-800-24 FRYER  
FAX: 1-318-862-2394**

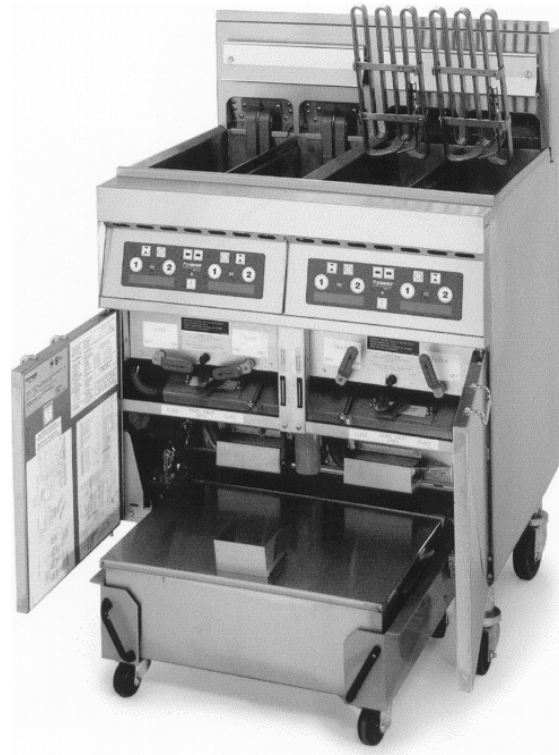

**TABLE OF CONTENTS**

WARRANTY STATEMENT .....Page i  
INTRODUCTION .....Page 1-1  
INSTALLATION INSTRUCTIONS .....Page 2-1  
OPERATING FRYERS WITH M100B COOKING COMPUTERS .....Page 3-1  
OPERATING FRYERS WITH THERMOSTAT CONTROLLERS .....Page 4-1  
OPERATING THE BUILT-IN FILTRATION SYSTEM .....Page 5-1  
PREVENTIVE MAINTENANCE AND TROUBLESHOOTING.....Page 6-1  
SERVICE PROCEDURES AND WIRING DIAGRAMS .....Page 7-1  
PARTS LIST .....Page 8-1

The Frymaster Corporation, 8700 Line Avenue 71106, 5489 Campus Drive 71129  
P.O. Box 51000, Shreveport, Louisiana 71135-1000  
PHONE 318-865-1711 FAX 318-219-7135

## H14 SERIES ELECTRIC FRYERS CHAPTER 8: PARTS LIST

### 8.1 Accessories

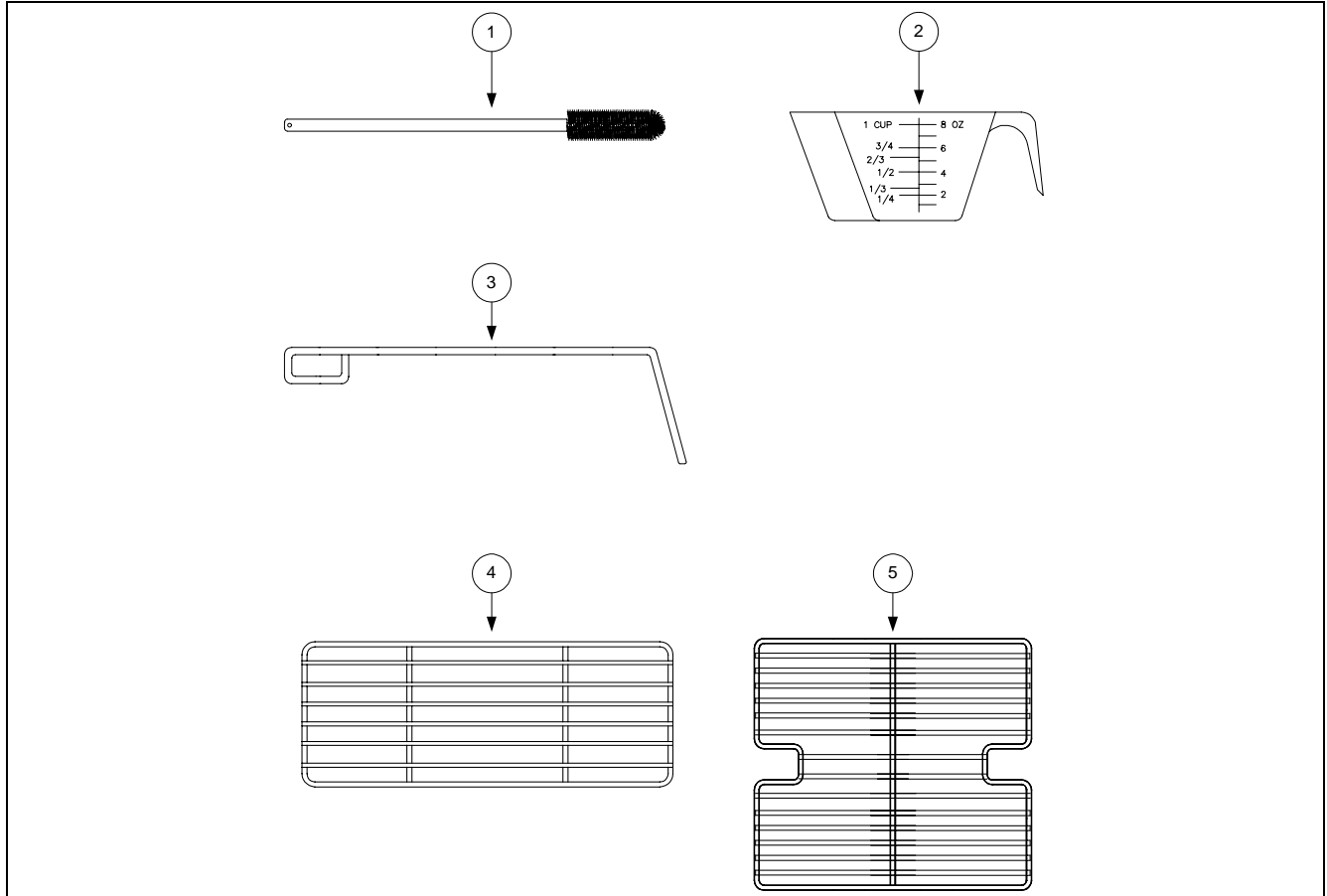

ITEM	PART #	COMPONENT
1	803-0209	Brush, FV/DV Frypot
2	803-0046	Cup, Measuring, Plastic, #1040
3	803-0197	Fryer Friend 27" (Clean-out Rod)
4	803-0106	Rack, Electric Dual-Vat Basket Support
5	803-0132	Rack, H50 Full-Vat With Probe Guard Basket
*	803-0002	Carton, Filter Powder
*	803-0170	Filter Pack- 100 Sheets
*	803-0219	Pad, McDonald's FPIII Universal Filter
*	806-0486	Cover, Frypot

\* Not Illustrated

## 8.2 Cabinet Assemblies and Component Parts

### 8.2.1 MH/BIH114 Cabinet Assembly, Single FootPrint

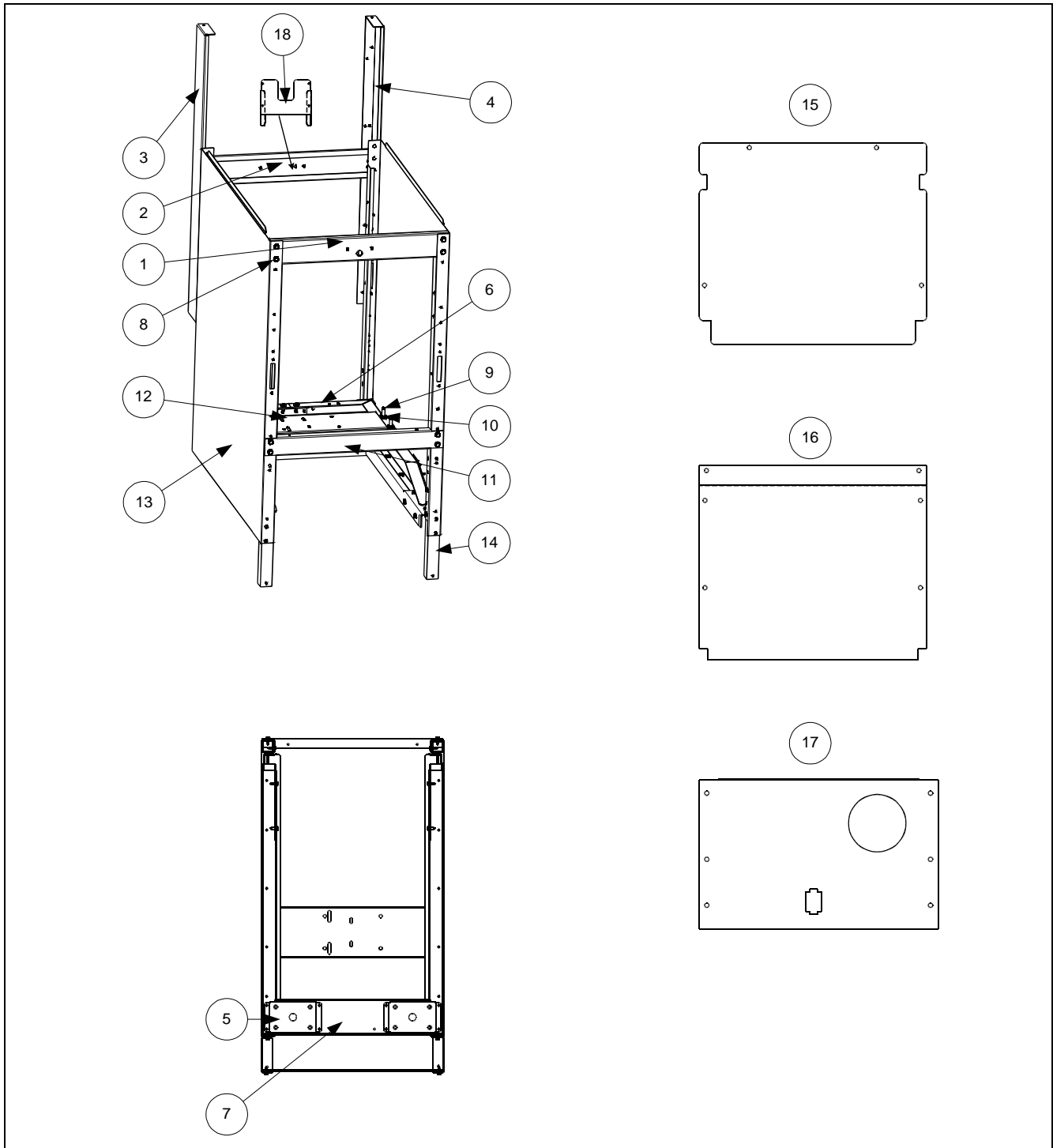

ITEM	PART #	COMPONENT
1	200-0129	Rail, Top Front Single
*	806-4910SP	Rail, Top Front Single (BIH114 prior to 1/99)
2	200-0130	Brace, Rear Horizontal
3	201-0137	Upright- rear enclosure
4	202-0137	Upright- rear enclosure
5	806-8059	Pad, Leg Assembly
6	806-8062	Rail, Pan Filter Assembly
7	806-8935SP	Base Assembly, FM 3-PIECE
	900-5313	Channel, CE FM Single Rear
	901-5316	Channel, CE FM LT Single Side
	902-5316	Channel, CE FM RT Single Side
*	806-7003SP	Base Assembly, Single Common Electric
8	826-1374	Screw, #10-1/2 Hex Head (Qty: 25)
9	826-1334	Bolt, 1/4-20 X 1 1/4 Hex Head (Qty: 5)
10	826-1368	Nut, Flange 1/4-20 Serrated (Qty: 10)
11	900-4391SP	Brace, Cabinet Front
*	900-4393SP	Brace, Cabinet Front (BIH114 prior to 1/99)
*	900-2733	Brace, Contactor Box, Front, N/F
*	900-2734	Brace, Support Contactor Box, Common Electric, N/F
12	900-8582	Mount, Motor Single FootPrint
13	910-2456SP	Side , Cabinet
*	911-9314SP	Side, Cabinet (BIH114 prior to 1/99)
*	912-9314SP	Side, Cabinet (BIH114 prior to 1/99)
14	910-8659	Leg, Cabinet Front, Single FootPrint
*	910-7925	Leg, Cabinet Front (BIH114 prior to 1/99)
15	900-2717SP	Back, Upper Cabinet
*	910-2912	Back, Upper Cabinet (BIH114 prior to 1/99)
16	900-5141	Back, Center Cabinet
17	900-8449	Back, Lower Cabinet
*	910-2911	Back, Lower Cabinet (BIH114 prior to 1/99)
18	900-9585	Heat Shield, Wire, Common Electric

### 8.2.2 MH/BIH214, 314, 414, 514 Cabinet Assemblies

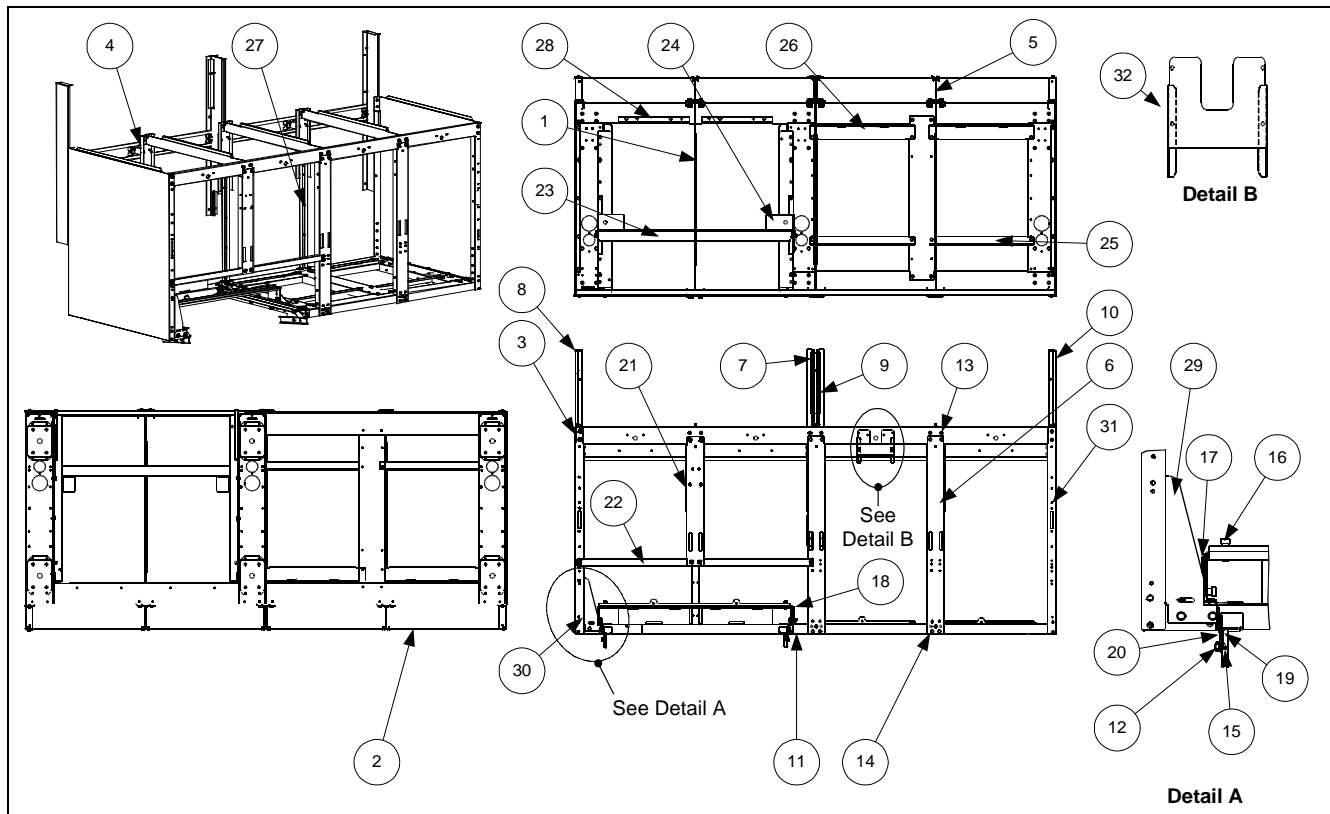

ITEM	PART #	COMPONENT
1	200-0076	Divider, Cabinet, Common Electric
2	200-0084	Brace, Rear Horizontal, 2 Battery (Quad and Double)
*	200-0085	Brace, Rear Horizontal, 3 Battery (Triple)
3	200-0091	Rail, Top- Quad Cabinet
*	200-0072	Rail, Top- Triple Cabinet
*	200-0081SP	Rail, Top- Double Cabinet
4	200-0092	Support, Rear, Common Electric
5	200-0126	Brace, Rear Support
6	200-0138	Door Post, Common Electric (Triple, Quad w/filter; Double, Triple, Quad N/F)
7	201-0093	Enclosure, Rear Upright with Hole (Quad Only)
8	201-0137	Upright, Rear Enclosure, Common Electric
9	202-0093	Enclosure, Rear Upright with Hole (Quad Only)
10	202-0137	Upright, Rear Enclosure, Common Electric
11	806-7005SP	Base, Filter Assembly, Common Electric- Quad
*	806-6513SP	Base, Filter Assembly, Common Electric- Triple
*	806-6511SP	Base, Filter Assembly, Common Electric- Double
*	806-6997SP	Base Assembly, Common Electric N/F- Double
*	806-6999SP	Base Assembly, Common Electric N/F- Triple
*	806-7001SP	Base Assembly, Common Electric N/F- Quad
12	826-1376	Nut, 10-32 (Qty: 10)

ITEM	PART #	COMPONENT
13	826-1374	Screw, #10 1/2-Inch (Qty: 25)
14	809-0413	Spacer, Door Post (Quad and Triple Only)
15	809-0422	Screw, Shoulder- 10-32 x .40
16	809-0538	Bolt, Shoulder- 1/4-20 x 3/8
17	823-2290	Front Bridge Support, Left
18	823-2291	Front Bridge Support, Right
19	900-1957	Lock Filter
20	900-1959	Bracket, Mounting, Filter Lock
21	900-2463	Post, Center Door, Common Electric
22	900-2464SP	Brace, Lower, Front Horizontal, Common Electric
23	900-2514	Bridge, Common Electric
24	900-2653	Plate, Swivel, Common Electric
25	900-2718	Brace, Contactor, Front, Common Electric w/Filter-Quad
*	200-0078	Brace, Contactor, Front, Common Electric [(w/Filter-Triple), N/F- Quad)
*	200-0075	Support, Contactor, Front, Common Electric N/F
26	900-2720	Brace, Contactor, Rear, Common Electric-Quad
*	200-0077	Brace, Contactor, Rear, Common Electric [(w/Filter-Triple), N/F- Quad)
*	200-0074	Support, Contactor, Rear, Common Electric N/F
27	900-2861SP	Support, Bottom, Common Electric
28	900-5988	Support, Rear, Bridge Filter, Common Electric
29	901-1810	Gusset, Cabinet, Left
*	902-1810	Gusset, Cabinet, Right (BIH214 Only)
30	901-1948	Channel, Side Support
31	910-2456SP	Cabinet Side, Common Electric
*	900-8452	Back, Lower Quad
*	900-8451	Back, Lower Triple
*	900-8450	Back, Lower Double
*	900-5145	Back, Center Triple
*	900-5143	Back, Center Double
*	900-2511	Back, Upper Triple
*	900-2465	Back, Upper Double
32	900-9585	Heat Shield, Wire, Common Electric

\* Not Illustrated

### 8.3 Casters, Legs and Associated Hardware

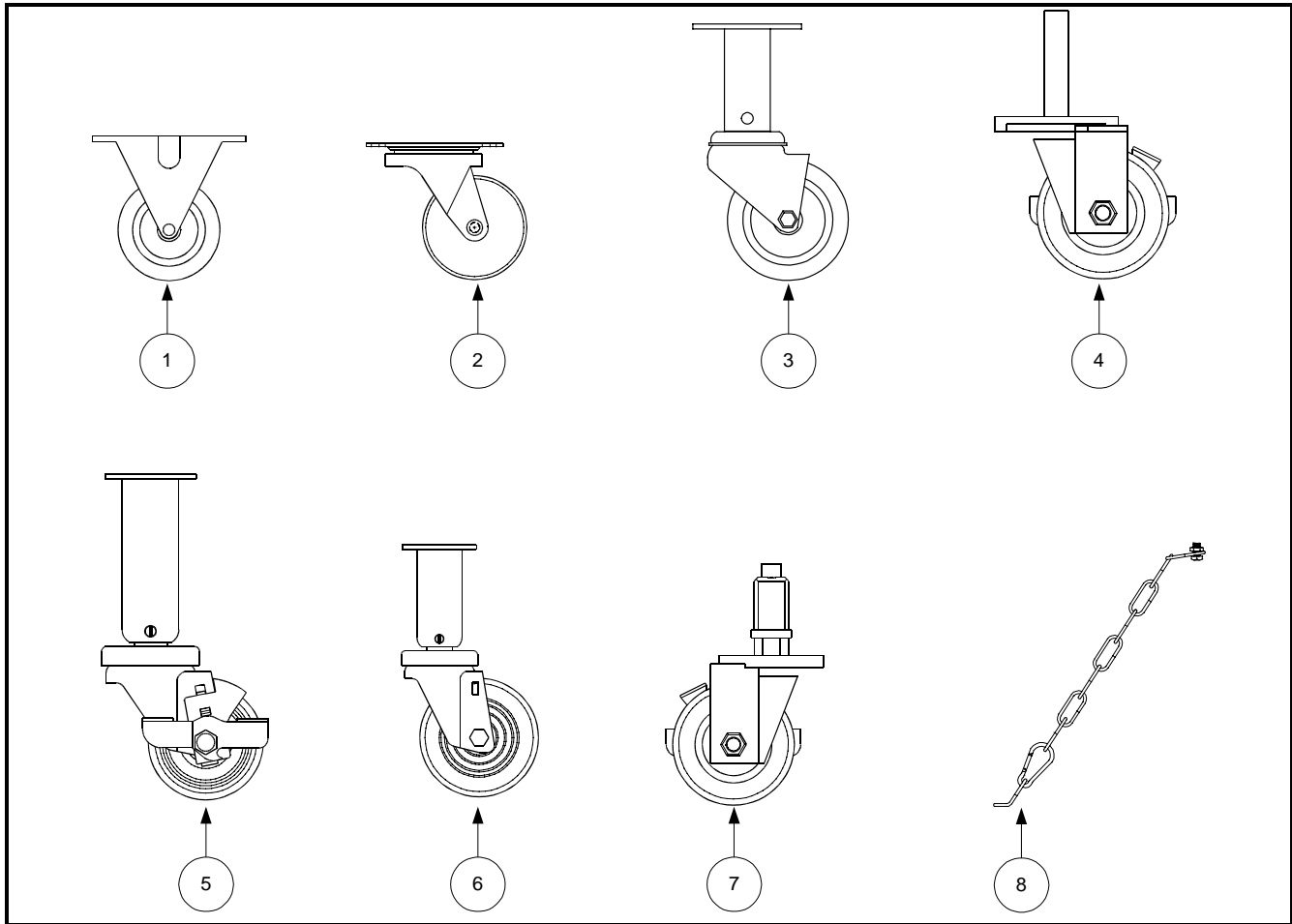

ITEM	PART #	COMPONENT
1	810-0005	Caster, Rigid
2	810-0006	Caster, Swivel-Rokite
3	810-0327	Caster, Adjustable, Without Brake
4	810-1565	Caster, Stud, Single FP 3", With Lock
5	810-0944	Caster, Adjustable 3" With Brake
6	812-1326	Caster W/A, 152-2 Adjustable With Brake
7	823-2844	Caster W/A, Front Common Electric, Single FootPrint
8	826-0900	Chain Restraint Kit (for use on fryers w/casters)

### 8.4 Component Box Assemblies/Associated Component Parts

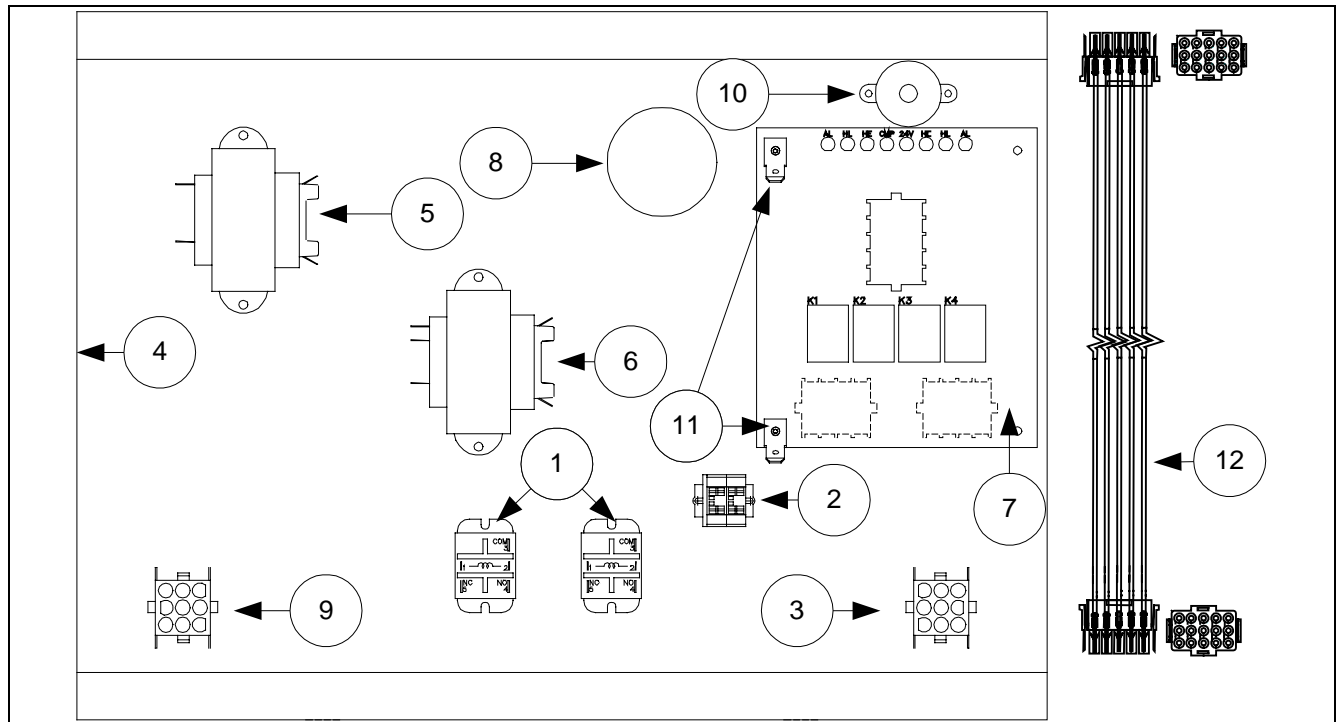

ITEM	PART #	COMPONENT
1	807-1683	Relay, Burnoff (McDonald's CE Models Only)
2	810-1164	Terminal Block Wire Assembly
3	806-6863SP	Wire Assembly, Burnoff, Full-Vat (McDonald's CE only)
3	806-6864SP	Wire Assembly, Burnoff, Dual-Vat (McDonald's CE only)
4	806-8244	Component Box/Stud Assembly
5	807-2191	12 VAC Transformer, 208-240 V
5	807-2192	12 VAC Transformer, 100-120V
6	807-2180	24 VAC Transformer, 208-240 V
6	807-2181	24VAC Transformer, 100-120V
7	806-6336	Interface Board
8	807-1084	Bushing
9	806-6854SP	Wiring Assembly, Transformer
10	806-7179SP	Sound Device
11	826-1337	Terminal Tab (Qty: 5)
12	806-2071	Cable Assembly, Computer/Interface Board



## 8.5 Control Panel Assemblies/Top Caps/Door Assemblies/Related Components

### 8.5.1 Control Panel Assemblies and Top Caps

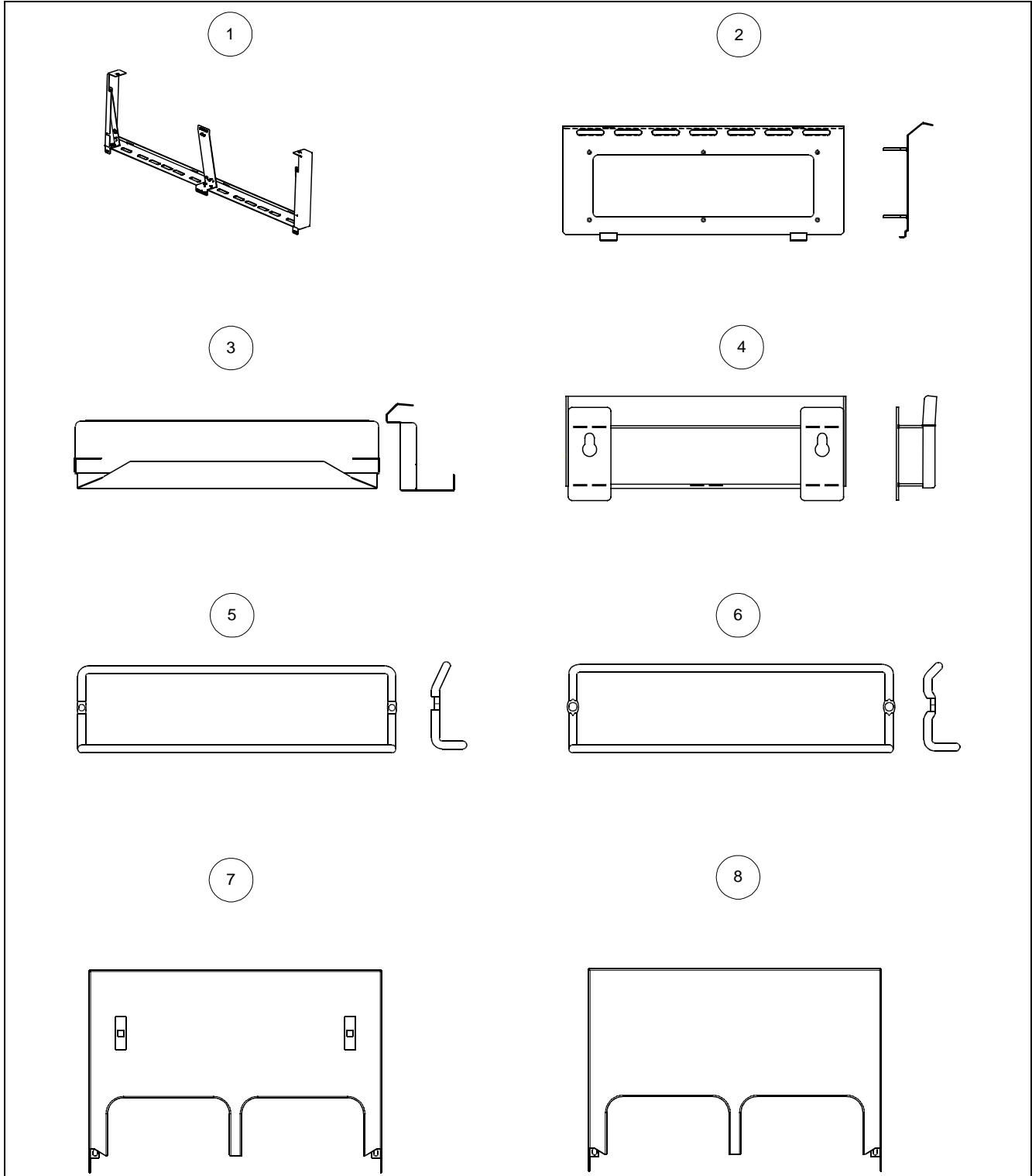

ITEM	PART #	COMPONENT
1		Control Panel Assembly
	806-9821SP	Center Brace, Control Panel (Double, Triple, Quad)
	809-0396	Screw, #6-32 x 3/8 Phillips Pan Head, Type F
	900-2732	Bracket, Control Panel Support
	910-4808	Frame, Control Panel Bottom, Single
	910-7045	Frame, Control Panel Bottom, Double
	910-9256	Frame, Control Panel Bottom, Triple
	910-9419	Frame, Control Panel Bottom, Quad
	911-2730	End, Control Panel (Left)
	912-2730	End, Control Panel (Right)
2	823-2307	Control Panel, with Slot
3	824-0577	Top Cap, Single Fryer
*	824-0575	Top Cap, Two-Fryer Battery
*	824-0576	Top Cap, Three-Fryer Battery
*	824-0578	Top Cap, Four-Fryer Battery
4	823-1618	Basket Hanger, McDonald's
5	810-1401	Basket Hanger, Wire
6	810-1403	Basket Hanger, Wire-Offset
7	824-0532	Housing, MAC114 Tilt w/o cap/splash
*	824-0534	Housing, MAC214 Tilt w/o cap/splash
*	824-0535	Housing, MAC314 Tilt w/o cap/splash
*	824-0536	Housing, MAC414 Tilt w/o cap/splash
*	910-7443	Top Connecting Strip (for fryers w/o cap/splash)
*	910-2420	Strip, MAC114 Electric Hood (for fryers w/o cap/splash)
*	910-2439	Strip, MAC 414 Electric Hood (for fryers w/o cap/splash)
*	910-2440	Strip, MAC 314 Electric Hood (for fryers w/o cap/splash)
*	910-2441	Strip, MAC 214 Electric Hood (for fryers w/o cap/splash)
8	824-0645	Housing, MAC114 HE Tilt with cap/splash
*	824-0647	Housing, MAC214 HE Tilt with cap/splash
*	824-0648	Housing, MAC314 HE Tilt with cap/splash
*	824-0646	Housing, MAC414 HE Tilt with cap/splash
*Not Illustrated		

### 8.5.1 Door Assembly Components

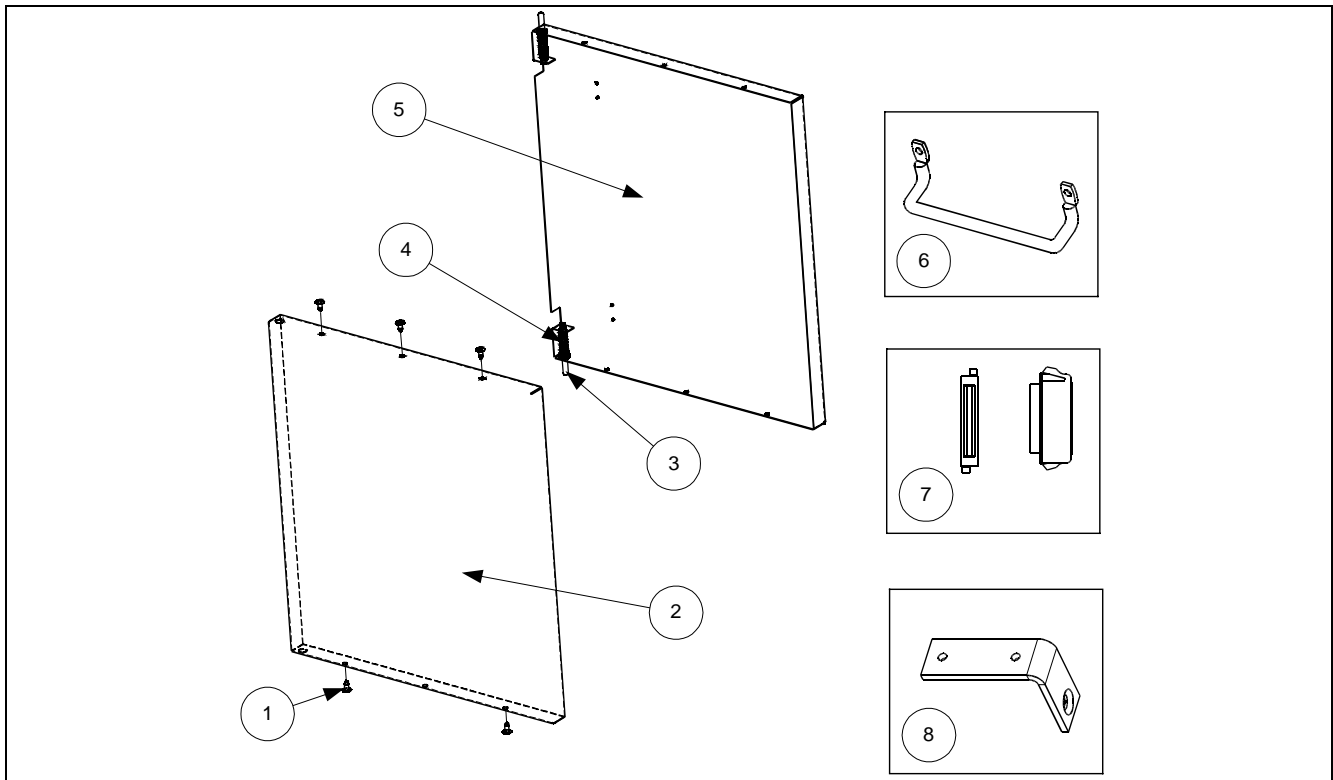

ITEM	PART #	COMPONENT
	806-6545SP	Door Assembly, Universal
1	809-0266	Screw, #10- 1/2-inch
2	824-0137SP	Panel, Door
3	806-4487SP	Door Pin Assembly
*	809-0193	Washer, Flat 1/4-Inch Nylon (Door Pin Bushing)
4	826-1343	Spring, Door Hinge (Qty: 10)
5	900-2485	Liner, Door
6	810-1422	Handle, Wireform, Door
7	810-1105	Magnet, Door
8	810-1508	Hinge, Universal Door
* Not Illustrated		

## 8.6 Controller Assemblies

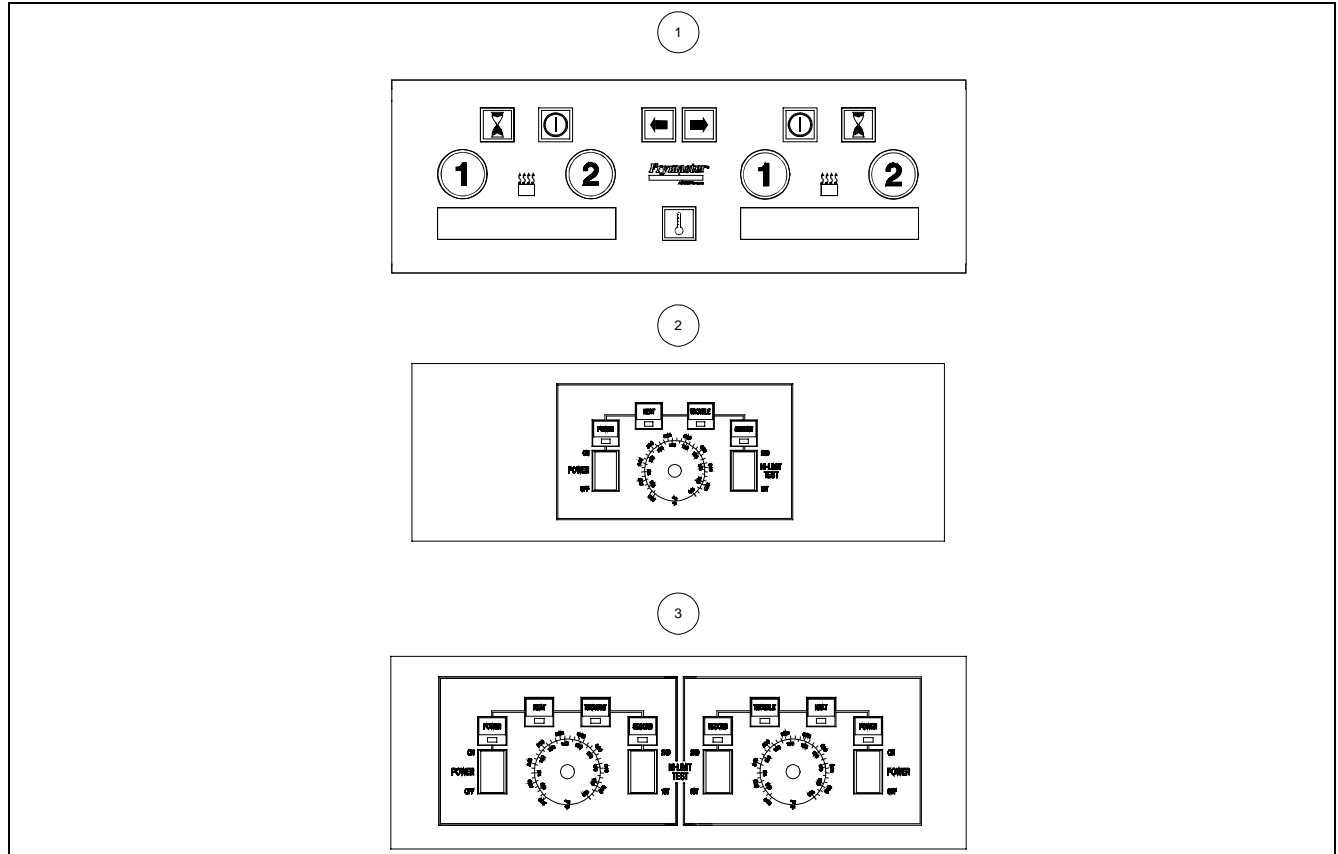

ITEM	PART #	COMPONENT
1	806-7990	Computer, M100B
*	806-8000	Computer, M100B Standard, Electric
*	806-8036	Computer, M100B, International
*	806-8103	Computer, M100B, CE Electric
2	806-7436	Controller, Full-Vat, MH/BIH14
3	806-7437	Controller, Dual-Vat, MH/BIH14
* Not Illustrated		

## 8.7 Drain System Components

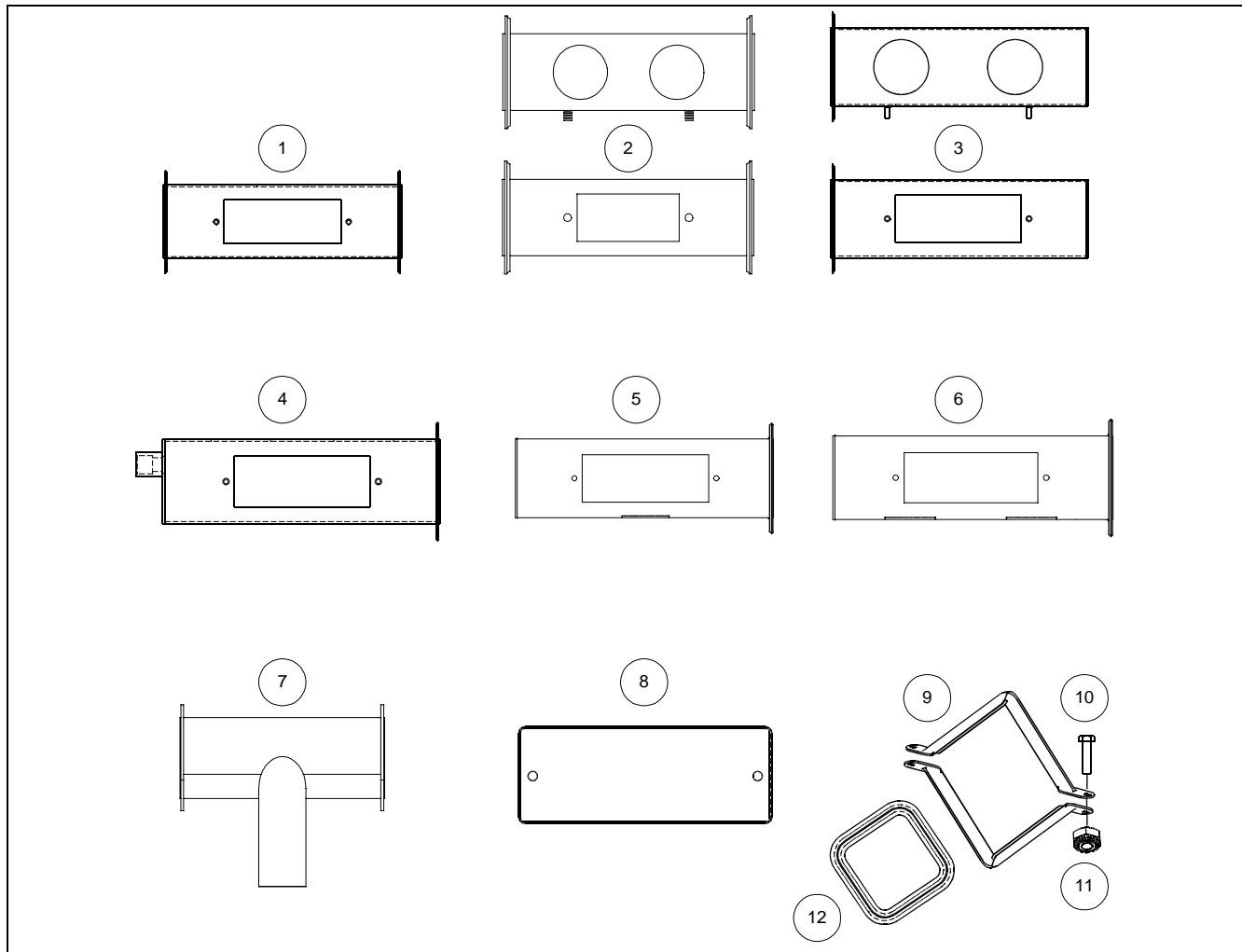

ITEM	PART #	COMPONENT
1	823-0718	Drain Tube, Left End, 2.5 x 8.0"
2	823-0725	Drain Tube, Left End, Dual-Vat, 2.5 x 8.0"
3	823-1551	Drain Tube, Right End, Dual Vat
4	823-2636	Drain Tube, Left End, Dual-Vat
*	823-2637	Drain Tube, Left End, Full-Vat
5	823-1549	Drain Tube, Right End, Full-Vat
6	823-1543	Drain Tube, Right End, Dual-Vat
7	823-2336	Drain, FootPrint
8	826-1348	Cover, Drain Cleanout (Qty: 5)
9	810-0396	Clamp, 2.5" Drain, Filter Magic (Two Required Per Union)
10	826-1375	Screw, 10-32 x 3/4 Hex Trim HD SS (Qty: 5)
11	8261376	Nut, 10-32 Hex (Qty: 10)
12	816-0032	Gasket, Square Drain

\* Not Illustrated

## 8.8 Electrical Components: Contactors, Elements and Related Components

### 8.8.1 Contactors

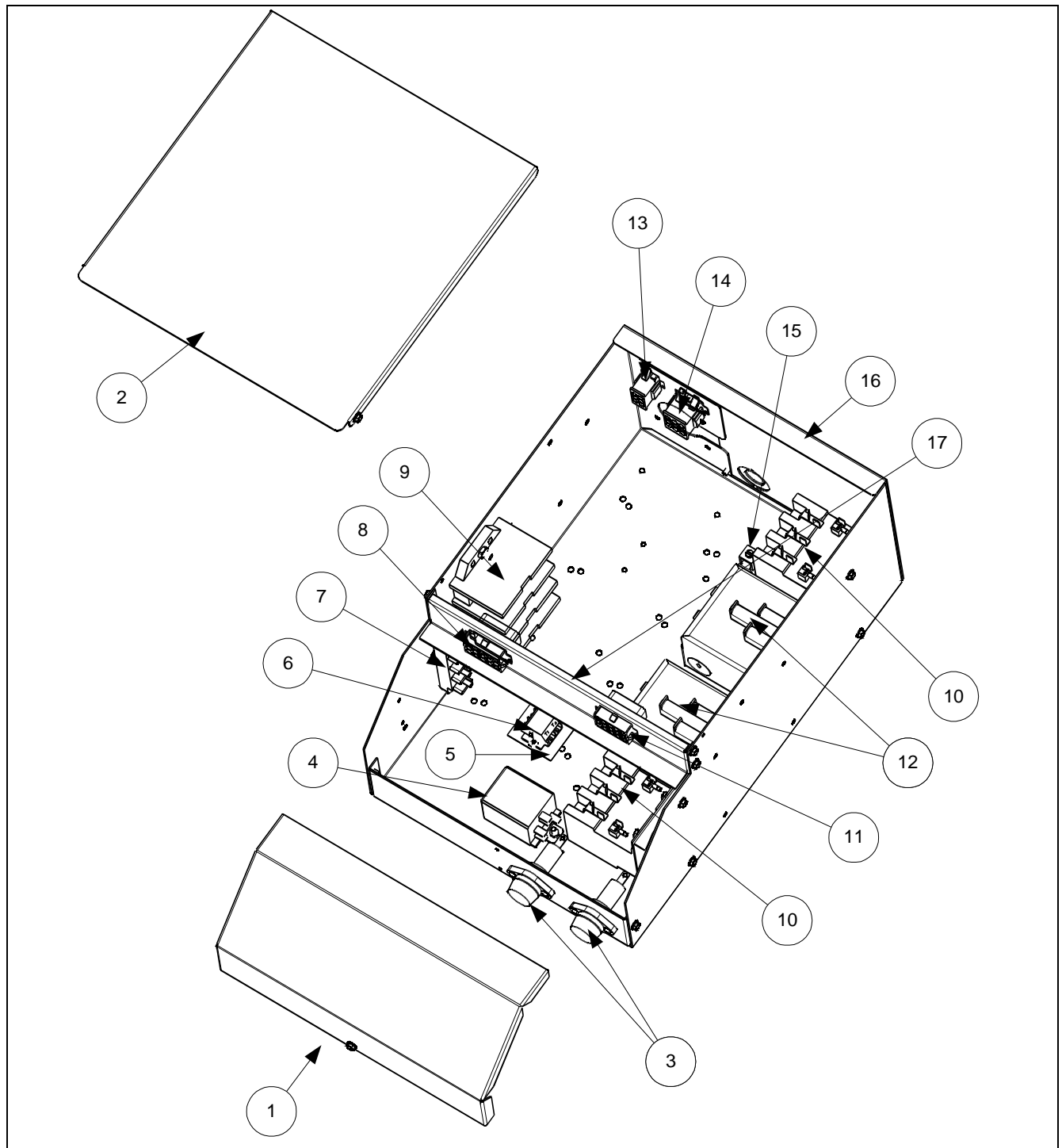

ITEM	PART #	COMPONENT
1	900-5445	Front Cover, Contactor Box
2	900-5446	Top Cover, Contactor Box
3	807-0922	Holder, Buss Fuse
*	807-2278	Fuse, 20 Amp
4	807-2515	Relay, 120V SPDT, 10A
5	816-0217	Paper, Insulating Terminal Block (CE)
6	810-1164	Terminal Block
7	807-1973	Terminal Post
8		C1 Wiring Assembly
	806-7664SP	McDonald's Domestic, Full-vat
	806-7669SP	McDonald's Domestic, Dual-vat
	806-8095SP	McDonald's CSA, Full-vat
	806-8096SP	McDonald's CSA, Dual-vat
	806-7197SP	McDonald's Export, Full-vat
	806-8017SP	McDonald's Export, Dual-vat
9	807-2464	Power Block, Delta
10	810-1202	Contactor, 3-Pole 600V 40 Amp
11		C2 Wiring Assembly
	806-8269	McDonald's Domestic, Full- and Dual-vat
	806-7666SP	McDonald's Export, Full- and Dual-vat
	806-8094	McDonald's CSA, Full- and Dual-vat
12	807-1071	Contactor, Mercury 24 VAC 30 Amp
13	806-7183SP	Wire Assembly, Left, Dual-vat
*	806-7186SP	Wire Assembly, Left, Full-vat
14	806-7185SP	Wire Assembly, Right, Full- and Dual-vat
15	807-0070	Terminal, Ground Lug
16	900-5447	Back Cover, Contactor Box
17	900-5782	Bracket, Connector-Common Electric
* Not Illustrated		

### 8.8.2 Elements and Related Components

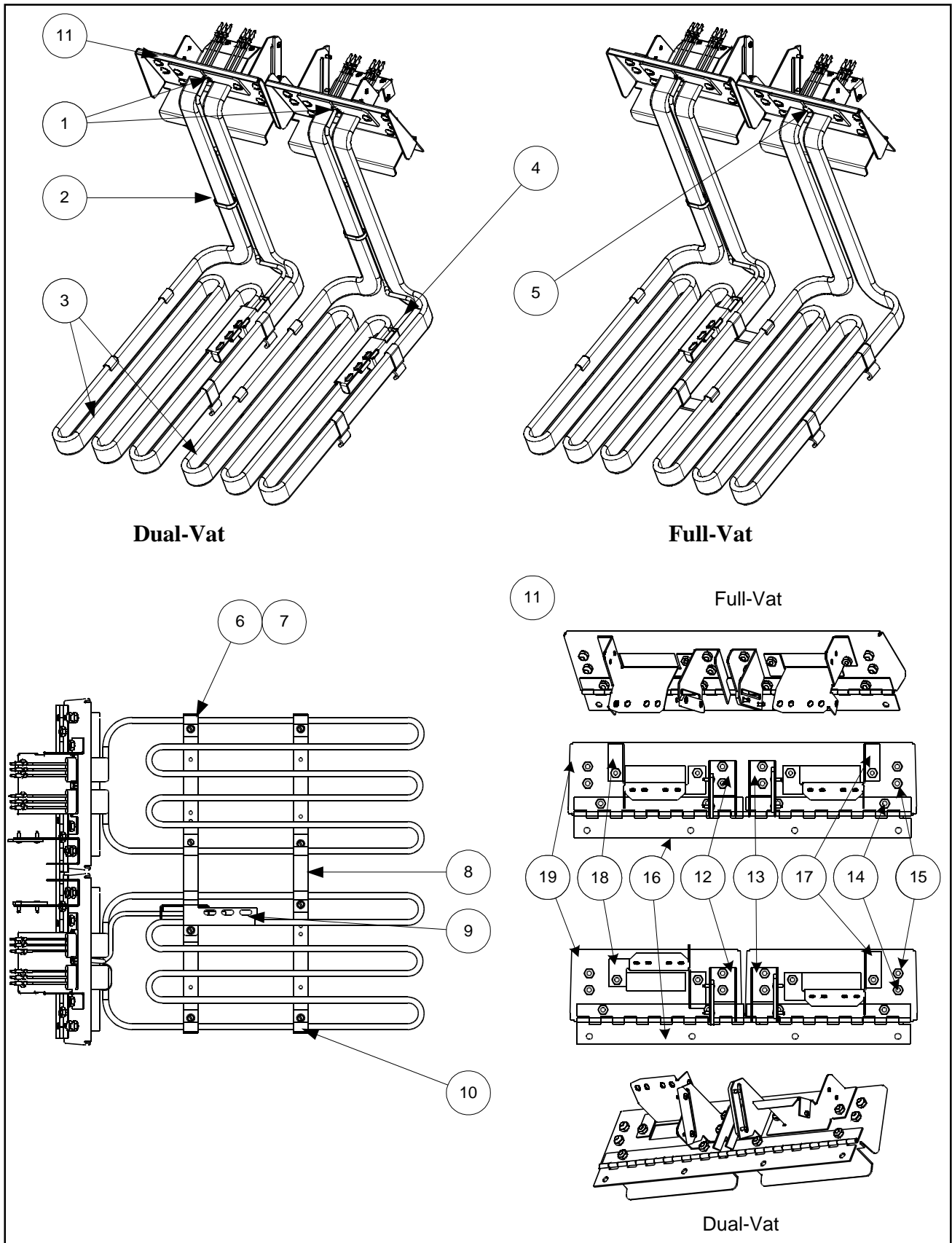



ITEM	PART #	COMPONENT
1	826-1339	Bushing, .375 Split (Qty: 10)
2	809-0567	Ty-Wrap, Metal
3		Heating Element
	807-2639	Heating Element, 208V 7 kW
	807-2641	Heating Element, 220V 8.5 kW
	807-2642	Heating Element, 230V 7 kW
	807-2643	Heating Element, 230V 8.5 kW
	807-2644	Heating Element, 240V 7 kW
	807-2645	Heating Element, 240V 8.5 kW
	807-2651	Heating Element, 480V 7 kW
	806-8474SP	Heating Element Assembly, 240V 14 kW Full-Vat
	806-8520SP	Heating Element Assembly, 230V 15.6 kW Full-Vat
	806-8523SP	Heating Element Assembly, 230V 17 kW Dual-Vat
4	807-2478	Temperature Probe
5	816-0480	Dome Plug, .375 OD. (Full-Vat Only)
6	809-0518	Screw #8 32 x 3/8-inch
7	910-2042	Clamp, Element
8	910-3681	Element Support, Full-Vat
*	910-5214	Element Support, Dual-Vat
9	910-5022	Bracket, Temperature Probe
10	910-5213	Clamp, H14/H17 Element
11	106-0003SP	Tilt Plate Assembly, Full-vat
*	106-0004SP	Tilt Plate Assembly, Dual-vat
		Tilt Plate Assembly, Individual Components
12	806-8285SP	Spring Slot Bracket Assembly, Right
13	806-8286SP	Spring Slot Bracket Assembly, Left
*	810-0297	Spring, Element
14	826-1330	Screw, 10-32 x 3/8 (Qty: 25)
15	826-1376	Nut, 10-32 (Qty: 10)
16	810-0035	Hinge, Stainless Steel Split—14-Inch
17	901-8509	Bracket, Element Support, Left
18	902-8509	Bracket, Element Support, Right
19	910-9640	Plate, Tilt, Full-Vat (1 Required)
19	910-9641	Plate, Tilt, Dual-Vat (2 Required)
* Not Illustrated		

### 8.8.3 Hood Relay Box, Power Cords and Hood Cords

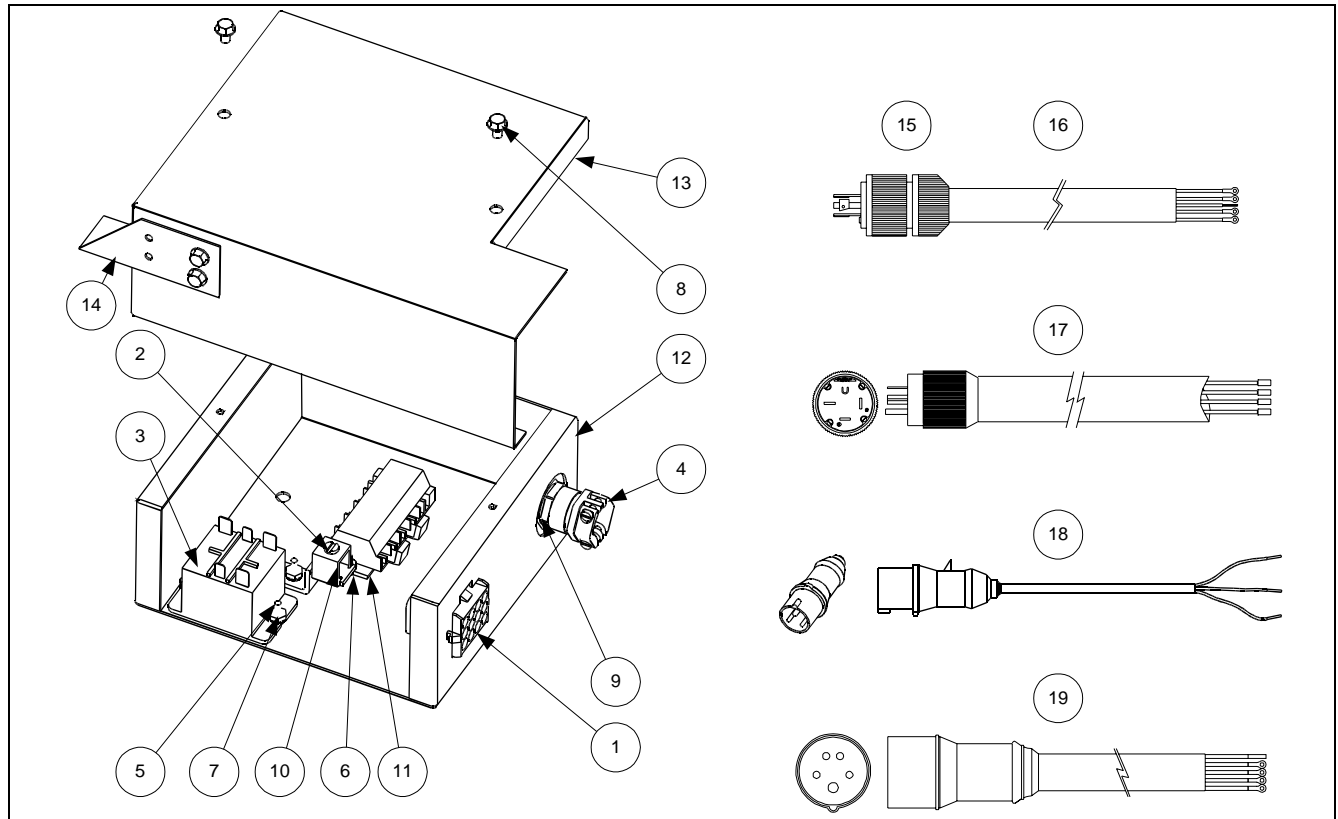

ITEM	PART #	COMPONENT
1	806-9381SP	Wire Assembly, CE Mac
*	806-9389SP	Wire Assembly, Non-CE Mac
2	807-0070	Terminal, Ground Lug
3	807-1683	Hood Relay, 12VDC
4	807-1694	Strain Relief, HE
5	826-1363	Screw, #8- 32 x 1/2 (Qty: 25)
6	809-0238	Nut, 4-40 Hex
7	809-0247	Nut, 8-32 Hex
8	809-0359	Screw, #8- 32 x 1/4 Hex-slotted
9	809-0492	Nut, Lock
10	809-0656	Screw, 4-40 x 3/8 Round-slotted
11	810-1163	Terminal Block, Screwless
*	807-1973	Terminal, Post (Non-CE)
12	900-8024	Box, Control Cord, CE Mac
13	900-8025	Cover, Control Cord Box
14	901-1530	Bracket, Attaching, Control Panel
15	807-1558	Plug, 4 Pole 5 Wire 20A
16	806-5229	Cordset, 120V 5 Wire (Plug not included)
17	807-2392	Cordset, Power, 3 Phase, 4-Wire w/Plug
18	807-1696	Cordset, Power, Europe, 3-Wire w/Plug
19	806-8164SP	Cordset, Power, Full-vat Export

## 8.9 Filter Base/Pan Assemblies

### 8.9.1 Filter Base Assemblies

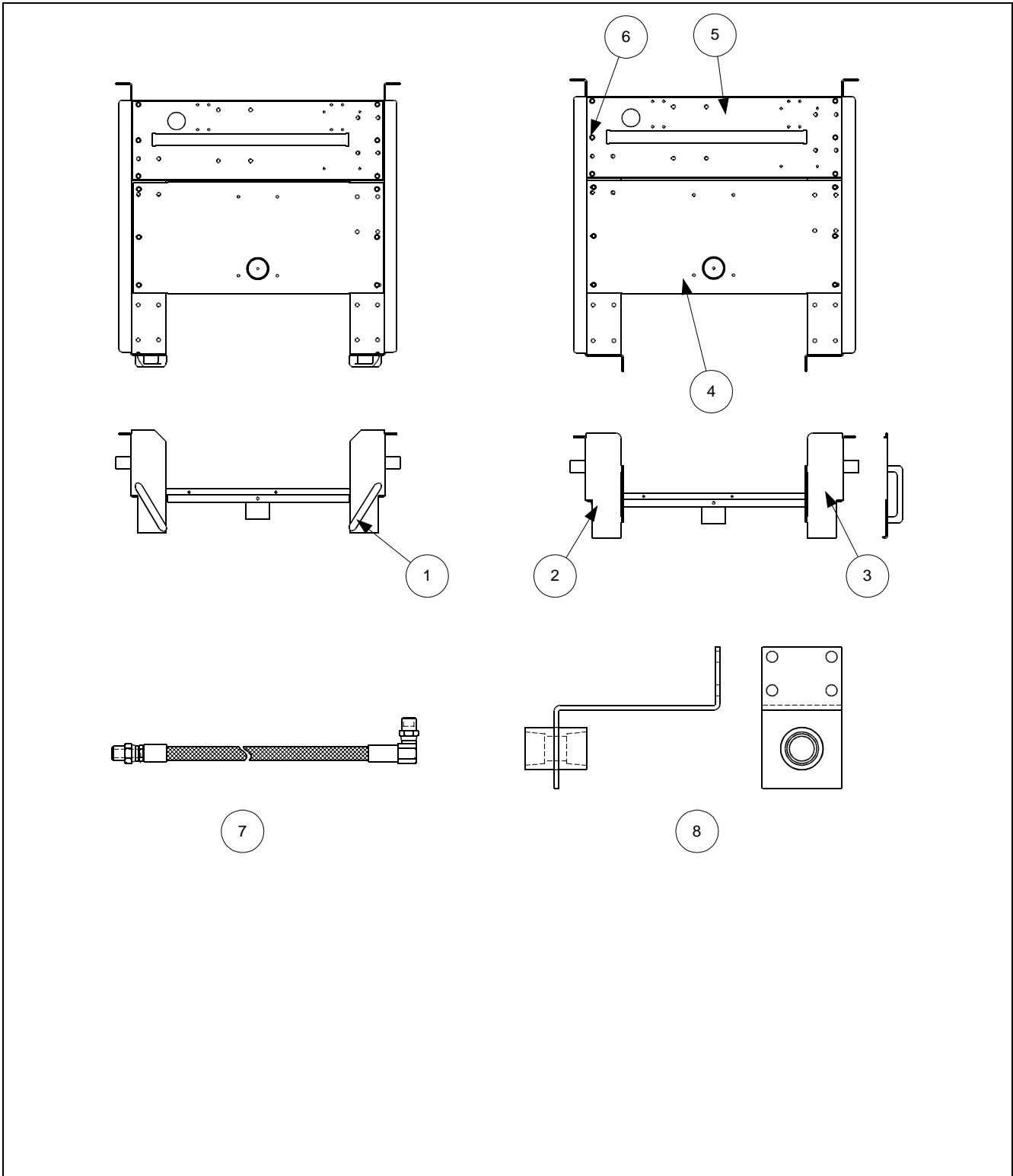

ITEM	PART #	COMPONENT
	806-8648SP	Filter Base Assembly, FootPrint III
1	810-0180	Handle, Filter Base Assembly
*	826-1360	Screw, #10-24 x 5/16 [Qty: 25 (to attach P/N 810-0180)]
2	901-8542	Filter Base, Left Side
3	902-8542	Filter Base, Right Side
4	823-2289	Filter Pan Support
5	900-5396	Motor Support
6	826-1374	Screw, #10-1/2 Hex Head (Qty: 25)
*	900-5477	Cover, Motor (August 1997 and later)
*	824-0558	Cover, Motor (Prior to August 1997)
*	900-1949	Standoff, Filter Wiring Box
7	810-1423	Hose, Oil Return
8	823-2638	Bracket, Oil Return Hose
<p>NOTE: P/N 810-0180 (Pull Handle) is available as a replacement for damaged handles on base assemblies manufactured from 8/97 to 8/99, If damaged filter bases need replacement, they must be replaced with P/N 901-8542 and 902-8542, in which includes handles. Filter bases with replaceable handles are no longer available.</p>		
<p>*Not Illustrated</p>		

### 8.9.2 Filter Pan Assemblies

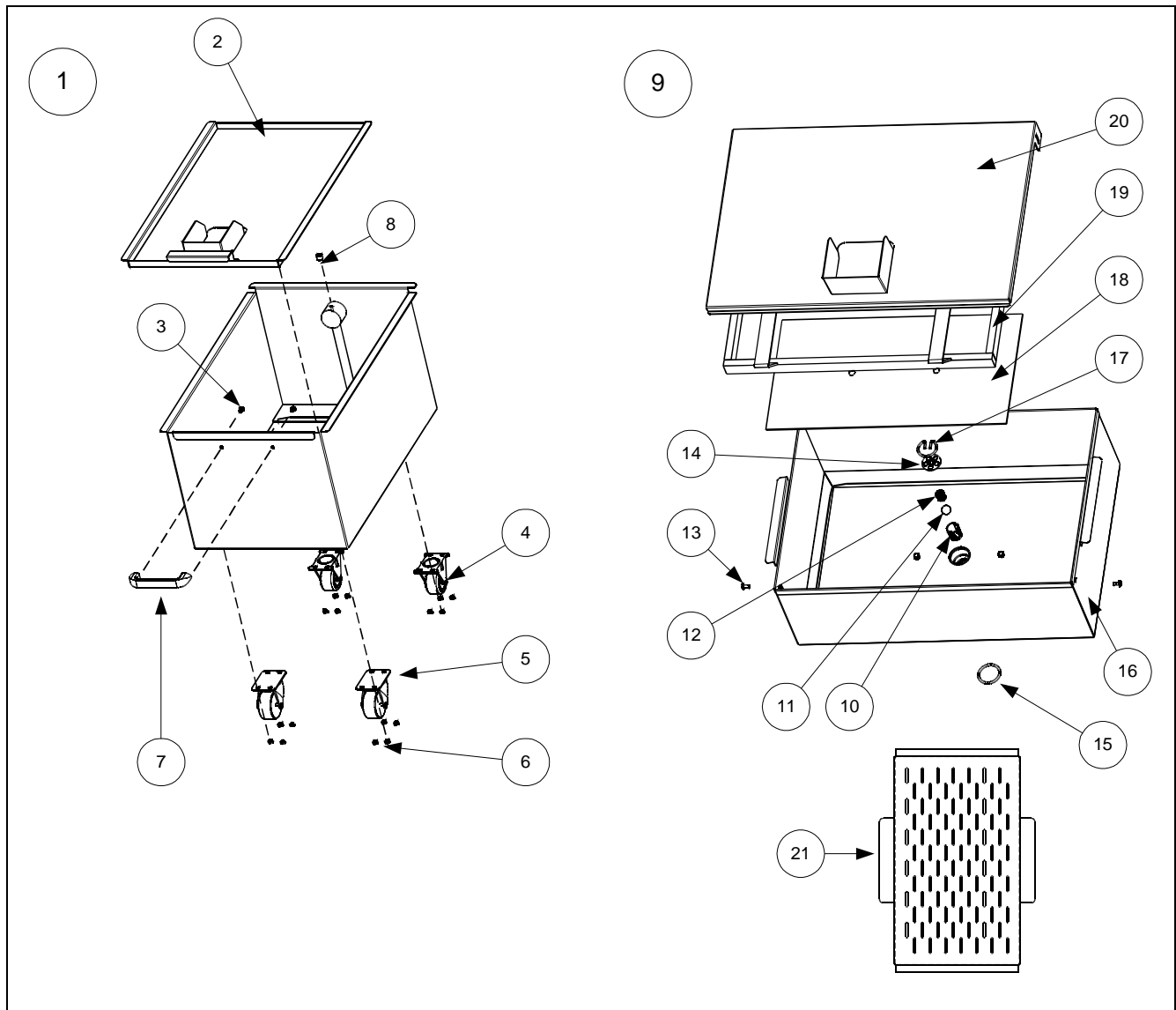

ITEM	PART #	COMPONENT
1	806-9546SP	Filter Pan Assembly, Single FootPrint
2	806-9547SP	Cover Assembly, Filter Pan
*	809-0045	Nut, 10-32
*	809-0117	Screw, 10-32 x 3/8 SS
*	809-0185	Washer, Flat #10
*	910-1816	Handle, Filter Pan, Single FootPrint
3	826-1360	Screw, 10-24 x 5/16 (Qty: 25)
4	810-0005	Caster, Rigid
5	810-0006	Caster, Swivel
6	826-1376	Nut, 10-32 (Qty: 10)
7	810-0180	Handle, Door
8	813-0411	Plug, Pipe-1/8 Internal Hex
9	806-6423SP	Filter Pan Assembly, FootPrint III
10	810-1388	Tube, Check Valve
11	810-0948	Ball, Check Valve
12	810-0946	Spring, Check Valve
13	809-0422	Screw, Shoulder 10-32 x 7/16
14	900-5448	Strain Plate, Check Valve
15	816-0181	O-Ring, Check Valve
16	823-2234SP	Filter Pan
17	810-1387	Retainer, Check Valve
18	900-8818	Screen
19	810-1405	Hold-down Ring
20	823-2027	Cover, Filter Pan
21	824-0430	Crumb Screen
*Not Illustrated		

### 8.10 Filter Pump and Motor Assemblies

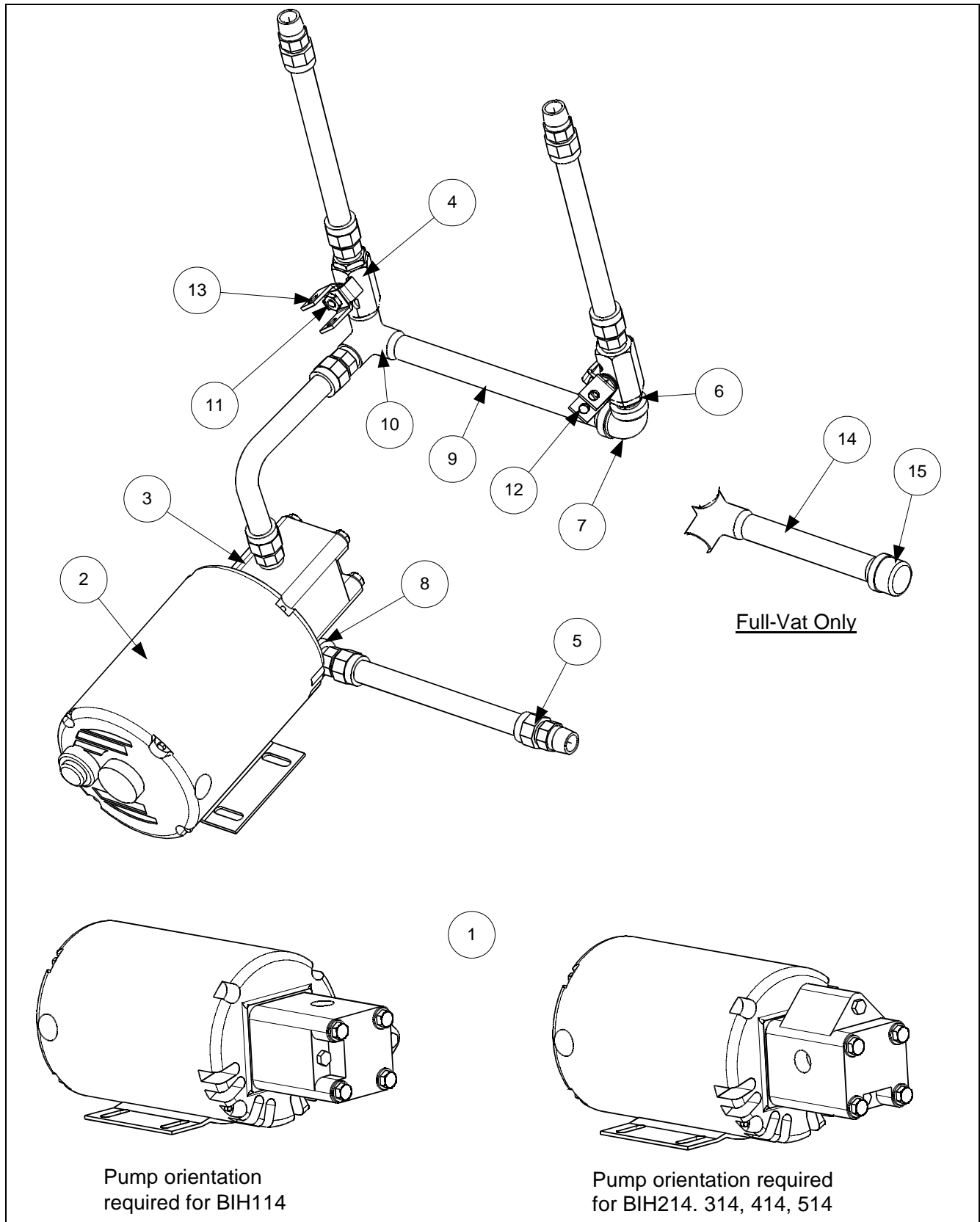

ITEM	PART #	COMPONENT
1	806-6118SP	Pump and Motor Assembly, 250V 50/60 Hz
2	826-1269	Motor and Gasket Kit, 230V 50/60 Hz
*	826-1266	Motor and Gasket Kit, 208V 50/60 Hz
3	807-1995	Pump, Viking 4 GPM
*	809-0514	Cap Screw, 5/16-18 Hex Head
*	809-0194	Washer, Flat 5/16-inch
*	816-0093	Gasket, Pump/Motor
4	810-0278	Gemini Valve without Handle
5	810-1067	Flex Line, Oil Return, 11-inch
6	813-0022	Nipple, 1/2-inch x Close (Dual-Vat Configuration)
7	813-0062	Elbow, 1/2-inch 90 Degree (Dual-Vat Configuration)
8	813-0165	Elbow, 1/2 x 1/2-inch 90 Degree
9	813-0253	Nipple, 1/2 x 10-inch (Dual-Vat Configuration)
10	813-0331	Elbow, 1/2-inch, With Side Outlet
11	900-2935	Nut, Retainer; Oil Return Valve
12	901-2772	Handle, Valve, Rearflush Left (Dual-Vat Configuration)
13	902-2772	Handle, Valve, Rearflush Right
14	813-0098	Nipple, 1/2 x 6.5-inch
15	813-0469	Cap, Pipe 1/2-inch
* Not Illustrated		



## 8.11 Filtration Systems: Oil Return Plumbing and Linkage Assemblies

### 8.11.1 Oil Return Plumbing Assemblies and Components

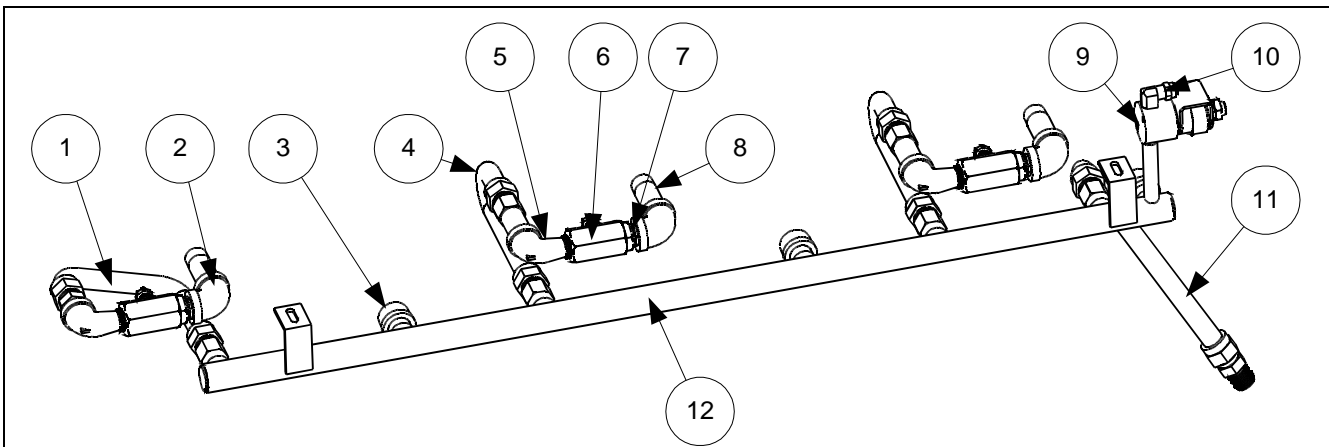

Manifold assembly for all H214, 314 and 414 fryers manufactured after 9/99.  
Multiple-battery fryers of five or more require a special one-piece manifold

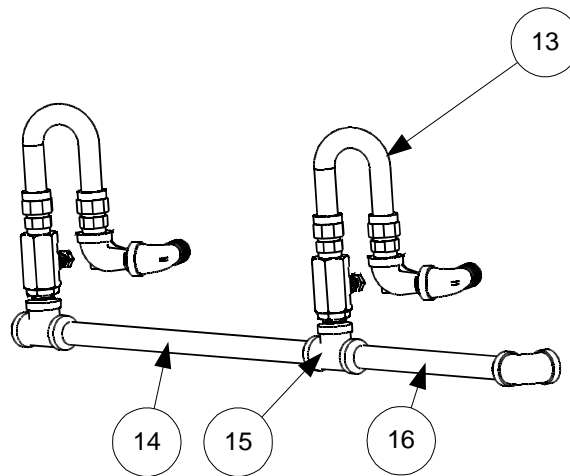

Manifold components for all H214, 314, 414 and 514 fryers  
manufactured before 9/99.

ITEM	PART #	COMPONENT
1	106-0002SP	Flex Line Assembly, With Male/Female Ends
2	813-0062	Elbow, ½-inch 90°
3	813-0469	Cap, Pipe ½-inch
4	106-0054SP	Flex Line Assembly, With Female Ends
5	813-0165	Elbow, Street, ½ x ½-inch 90°
6	810-0278	Gemini Valve, Without Handle
7	813-0022	Nipple, ½-inch Close NPT
8	813-0265	Nipple, ½ x 2.5-inch NPT
9	807-2484	Vent Valve, Solenoid ¼-inch NPT
*	812-1322SP	Vent Tube, Teflon 3/8-inch OD
10	810-1372	Fitting, 90°, ¼-inch NPT: 3/8 Tube
11	806-9439SP	Flex Line Assembly, 14-inch with Male/Female Ends
12	810-1517	Manifold, Oil Return, RF H314/17/22
*	810-1516	Manifold, Oil Return, RF H214/17/22
*	810-1518	Manifold, Oil Return, RF H414/17/22
13	810-1067	Flex Line, Oil Return, 11-inch
14	813-0509	Nipple, ½ x 14.5-inch NPT
15	813-0003	Tee, ½ x ½ x ½-inch
16	813-0275	Nipple, ½ x 9-inch NPT
*	813-0093	Nipple, ½ x 4-inch NPT
* Not Illustrated		

### 8.11.2 Oil Return Linkage Assemblies and Components

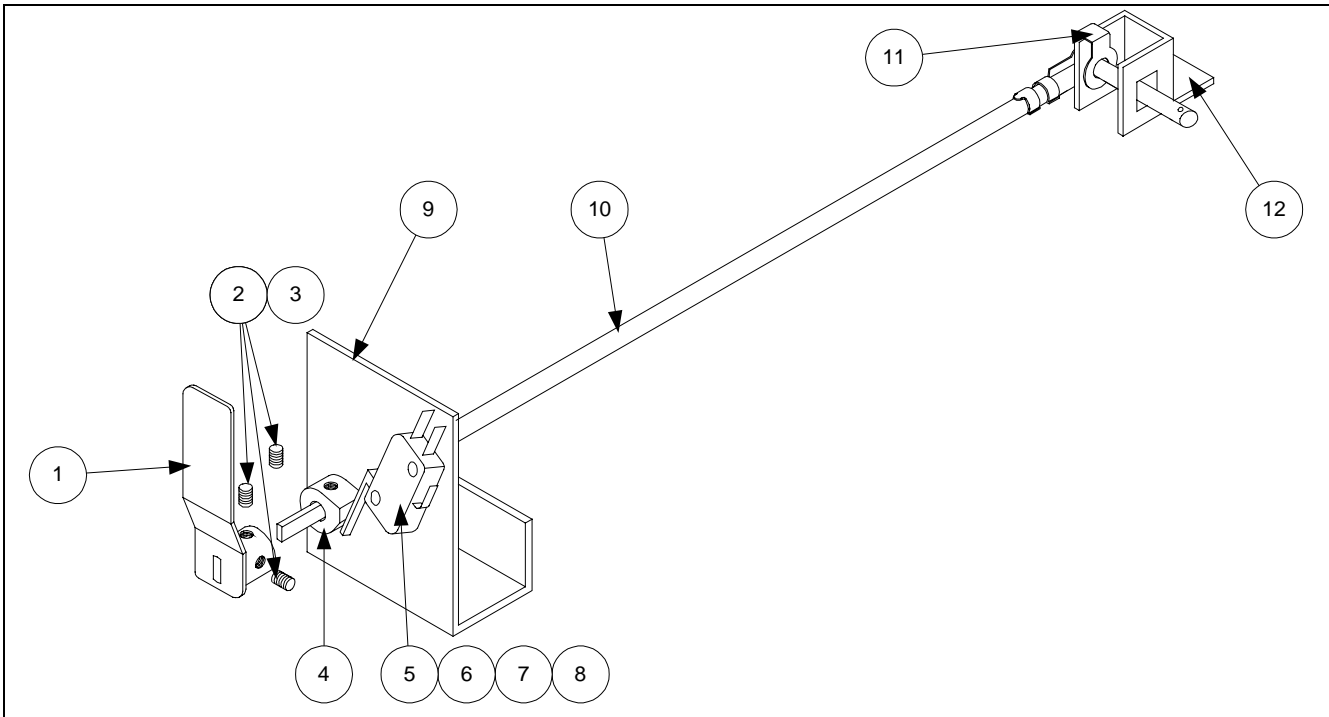

ITEM	PART #	COMPONENT
1	823-2337	Handle, Oil Return, Left
*	823-2338	Handle, Oil Return, Right
2	826-1377	Screw, Set 10-32 x 1/4 (Qty: 25)
3	815-0789	Loctite® Threadlocker 242
4	810-1186	Cam, Microswitch
5	807-2103	Microswitch
6	816-0220	Insulation, Microswitch/Bracket
7	826-1359	Screw, 4-40 x 3/4-inch (Qty: 25)
8	826-1366	Nut, 4-40 Hex with External Tooth (Qty: 25)
9	900-2571	Bracket, Microswitch
10	810-1180	Shaft, Rotating Arm
11	809-0601	Clip, Clevis 5/16-inch
12	901-2772	Handle, Valve, Rear Flush, Left
12	902-2772	Handle, Valve, Rear Flush, Right

\* Not Illustrated

### 8.12 Frypot Assemblies and Drain Valve Components

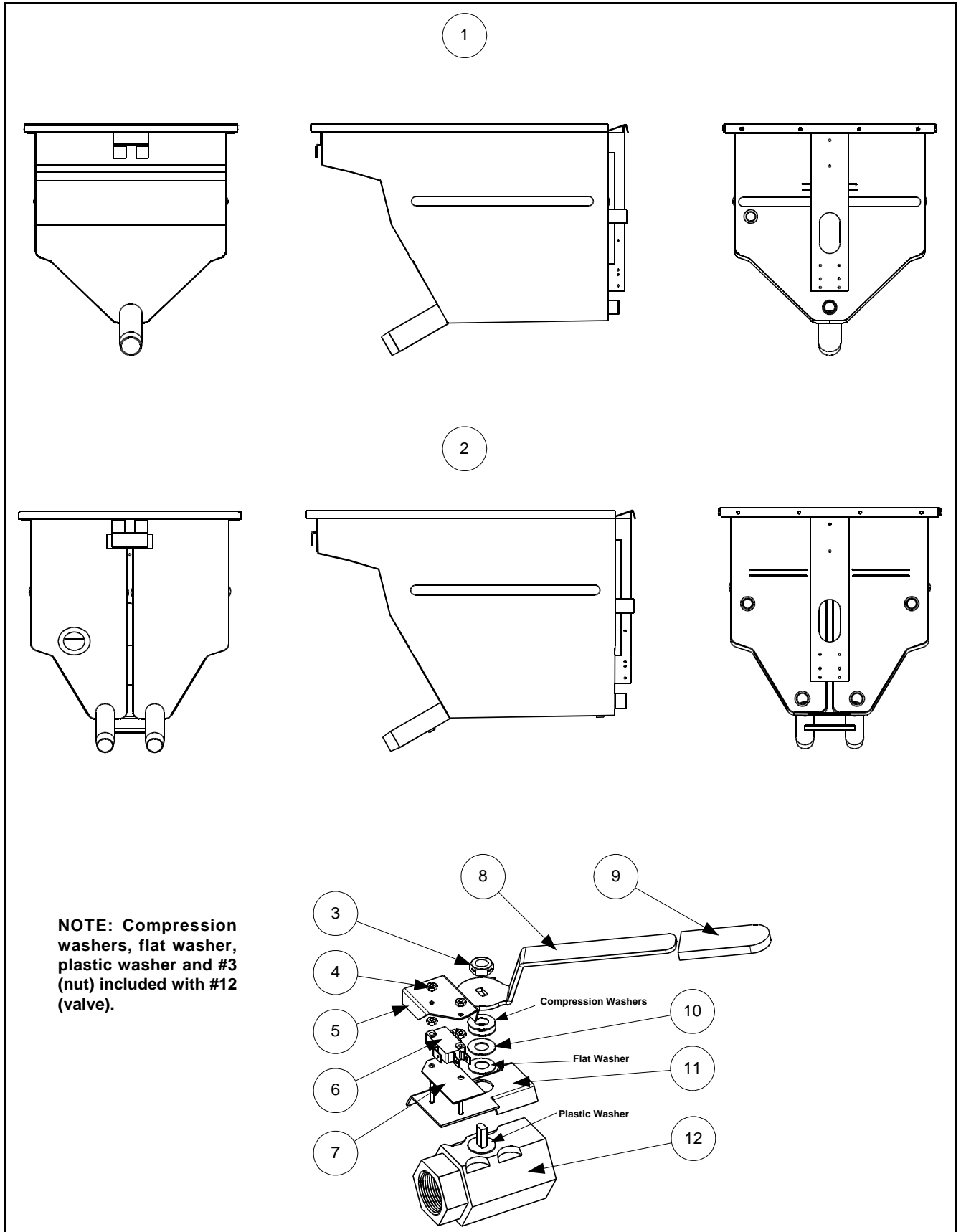

ITEM	PART #	COMPONENT
1	823-2454SP	Frypot Assembly, Full-Vat
2	823-2460SP	Frypot Assembly, Dual-Vat
		Drain Valve Assembly, Dual-Vat
3	809-0539	Nut, 3/8-16 2-Way Lock
4	826-1366	Nut, 4-40 Hex (Qty: 25)
5	901-2348	Cover, Safety Switch, Left DV
*	902-2348	Cover, Safety Switch, Right DV
6	807-2104	Microswitch
7	816-0220	Insulation, Microswitch/Bracket
8	900-2607	Drain Valve Handle, Left DV
*	900-2608	Drain Valve Handle, Right DV
9	814-0047	Sleeve, Valve Handle, Red with Logo
10	810-1165	Washer, Teflon
11	806-8194	Bracket, Microswitch, Left DV
*	806-8195	Bracket, Microswitch, Right DV
12	810-1338	Valve, 1 Inch Universal
*	806-7434SP	Drain Valve Assembly, Full-Vat
		Drain Valve Components, Full-Vat
3	809-0540	Nut, 2-Way Lock
4	826-1366	Nut, 4-40 Hex (Qty: 25)
5	900-2841	Cover, Safety Switch
6	807-2103	Microswitch
7	816-0220	Insulation, Microswitch/Bracket
8	900-2609	Drain Valve Handle
9	814-0047	Sleeve, Valve Handle, Red with Logo
10		<i>Not used on Full-vat Drain Valve Assemblies</i>
11	806-8137	Bracket, Microswitch
12	810-1020	Valve, Gemini 1-1/4-inch
* Not Illustrated		

### 8.13 Thermostats and Related Components

ITEM	PART #	COMPONENT
*	806-8035	High-Limit Thermostat (Dual-vat; Coded Red)
*	806-7543	High-Limit Thermostat (Full-vat; Coded Black)
*	806-8132	High-Limit Thermostat [All European Community (CE); Coded Yellow]
* Not Illustrated		