



Beginning with Series Code AN

**H14/H17/H22 SERIES  
ELECTRIC FRYERS  
Service & Parts Manual**



Frymaster, a member of the Commercial Food Equipment Service Association, recommends using CFESA Certified Technicians.

**24-Hour Service Hotline 1-800-551-8633**

**AUG 2005**

\* 8195 / 94 \*

## H14/H17/H22 SERIES ELECTRIC FRYERS CHAPTER 2: PARTS LIST

### 2.1 Accessories

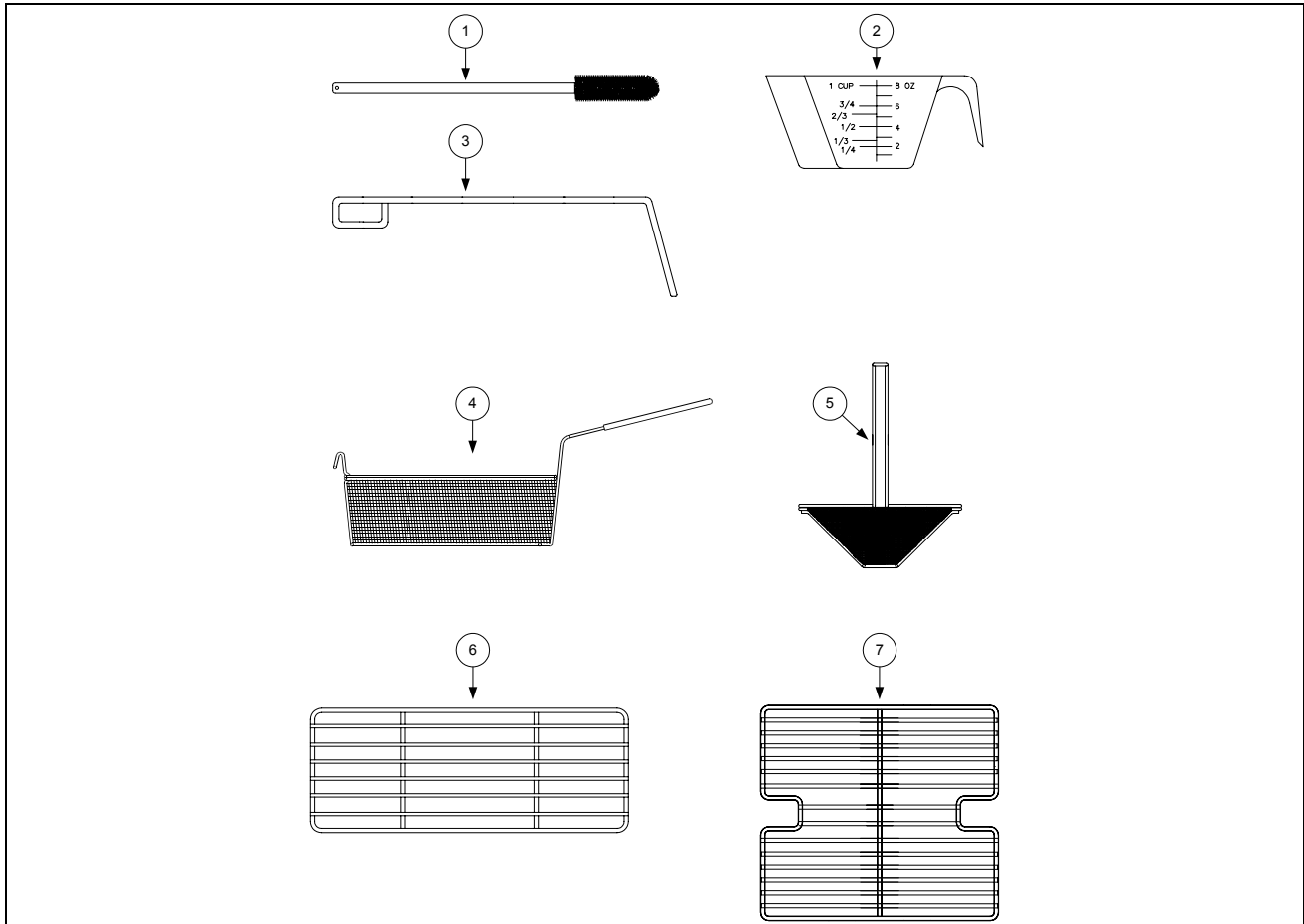

ITEM	PART #	COMPONENT
1	803-0209	Brush, FV/DV Frypot
2	803-0046	Cup, Measuring, Plastic, #1040
3	803-0197	Fryer Friend 27-inch (Clean-out Rod)
4	803-0099	Basket, Full-vat
*	803-0271	Basket, Dual-vat
5	803-0113	Sediment Tray, Full-vat
*	803-0122	Sediment Tray, Dual-vat, Left
*	803-0123	Sediment Tray, Dual-vat, Right
6	803-0106	Rack, Electric Dual-Vat Basket Support
7	803-0132	Rack, H50 Full-Vat With Probe Guard Basket
*	803-0002	Carton, Filter Powder
*	803-0170	Filter Pack– 100 Sheets
*	806-3068	Cover, Full Vat Frypot
*	806-3071	Cover, Dual Vat Frypot

\* Not illustrated.

## 2.2 Basket Lift Assemblies and Component Parts

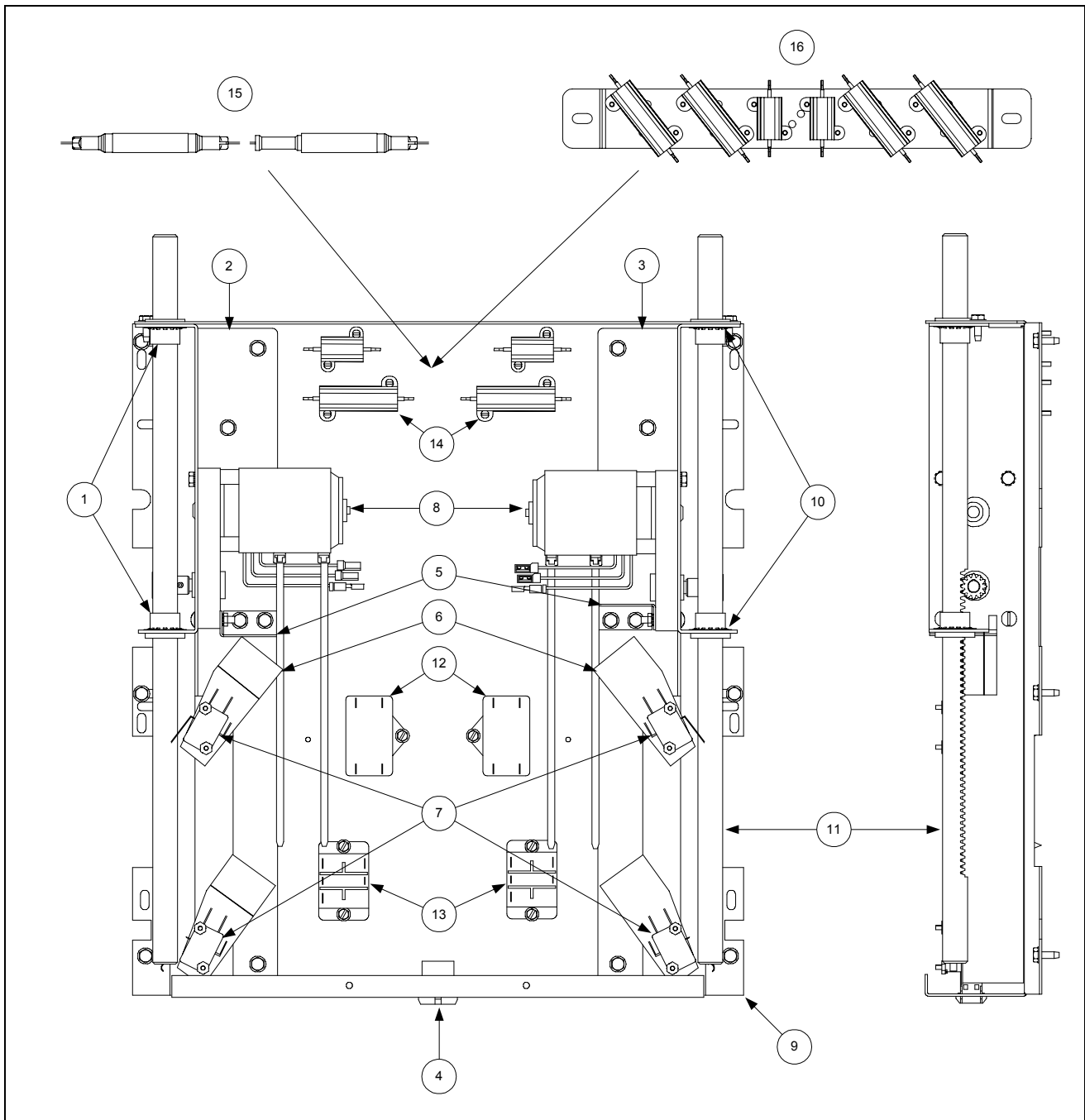

ITEM	PART #	COMPONENT
		<b>Common Components</b>
1	813-0035	Bushing, Bronze, .640-inch ID
2	901-8499	Chassis, Modular Basket Lift, Left
3	902-8499	Chassis, Modular Basket Lift, Right
4	807-0158	Connector, 6-Pin Female, Panel Mount
5	900-5529	Gusset, Modular Basket Lift Motor
6	812-0442	Insulation, Microswitch
7	807-2572	Microswitch
8	806-5964SP	Motor Assembly, Modular Basket Lift
9	200-2942	Mount, MBL (for old mount w/6-pin plug use 900-7655)
10	809-0082	Ring, Retaining – Truarc
11	810-1012	Rod, Modular Basket Lift
*	823-2704	Left Basket Lift Arm
*	823-2705	Right Basket Lift Arm
12	807-2133	Capacitor, 12.5 $\mu$ Farad, 250VAC Motor
		<b>Resistors</b>
13	807-1683	Relay, 12V (All Basket Lifts w/Relays)
14	806-9185	Resistor Assembly, Modular Basket Lift (used in 806-8532SP)
15	806-8530	Resistor Assembly, Modular Basket Lift (used in 806-8531SP)
16		Resistor Assembly, Modular Basket Lift (see <b>NOTE</b> below)
	106-2770	200-220V (used in 806-8086SP and 806-8685SP)
	106-2771	230-250V (used in 806-8087SP and 806-8686SP)
		<b>Wire Assemblies</b>
	WIR00482	For 106-1807SP (for 6-pin MBL assembly 806-8531SP, use WIR0073SP)
	WIR0292	For 806-8532SP
	WIR0166	For 806-8086SP & 806-8087SP
	806-8555SP	For 6-pin assemblies 806-8685SP & 806-8686SP
	106-1804SP	For 12-pin assemblies 106-1809SP & 106-1810SP
		<b>Complete Assemblies</b>
	106-1807SP	100/120V w/o Relay (for 6-pin assembly, use 806-8531SP)
	106-1808SP	100/120V w/Relay (for 6-pin assembly, use 806-8532SP)
	106-1809SP	200/208/220V w/o Relay (for 6-pin assembly, use 806-8685SP)
	106-1805SP	200/208/220V w/Relay (for 6-pin assembly, use 806-8086SP)
	106-1810SP	230/240/250V w/o Relay (for 6-pin assembly, use 806-8686SP)
	106-1806SP	230/240/250V w/Relay (for 6-pin assembly, use 806-8087SP)

\* Not illustrated.

**NOTE:** Item 16 replaces all previous resistors and resistor assemblies used in 200-250V modular basket lifts.

## 2.3 Cabinet Assemblies and Component Parts

### 2.3.1 H114/117/122 Cabinet Assembly, Single FootPrint and Non-Filter

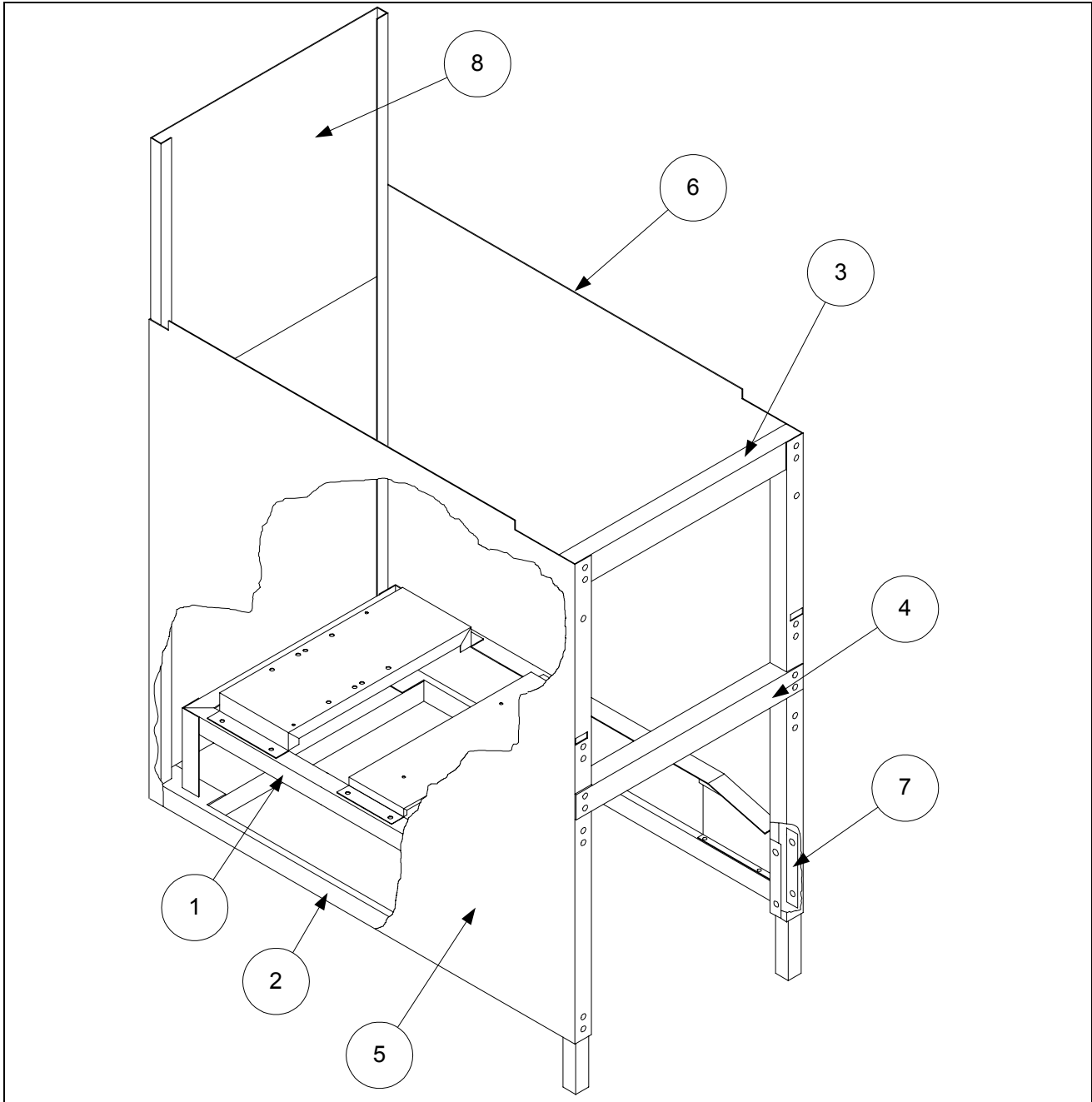

ITEM	PART #	COMPONENT
1	806-4910SP	Rail Assembly, Single FootPrint
*	200-0129	Rail, Top Front Single Common Electric N/F
2	806-4897SP	Base, Single FootPrint
*	806-7003SP	Base Assembly, Single Common Electric, N/F
3	900-4393SP	Brace, Top, Single FootPrint
4	900-4391SP	Brace, Cabinet Front
*	900-2733	Brace, Contactor Box, Front, N/F
*	900-2734	Brace, Support Contactor Box, Common Electric, N/F
*	200-0130	Brace, Rear Horizontal, Common Electric, N/F
*	201-0137	Upright- rear enclosure, Common Electric, N/F
*	202-0137	Upright- rear enclosure, Common Electric, N/F
5		Side, Cabinet – Left Side
	911-9314	Stainless Steel
	901-9314	Enameled Steel
6		Side, Cabinet – Right Side
	912-9314	Stainless Steel
	902-9314	Enameled Steel
*	910-2456SP	Cabinet Side, Common Electric N/F
7	900-1621	Plate, Rail Mount
8	910-2912	Back, Upper Cabinet, Single FootPrint
*	900-5204	Back, Cabinet, 22kW Single FP
*	900-4412	Bracket, Component, 22kW Single FP
*	900-2717SP	Back, Upper Cabinet, Common Electric, N/F
*	900-5141	Back, Center Cabinet, MH114
*	900-8449	Back, Lower Cabinet with U-shaped Cutout
*	200-4581	Back, Lower Cabinet without U-shaped Cutout
*	910-7925	Leg, Cabinet, Front Filter
*	900-9585	Heat Shield, Wire, Common Electric
*	826-1374	Screw, #10-1/2 Hex Head (Pkg. of 25)
*	826-1389	Screw, 1/4-20 x 3/4 Hex Head (Pkg. of 10)
*	826-1334	Bolt, 1/4-20 X 1 1/4 Hex Head (Pkg. of 5)
*	826-1368	Nut, Flange 1/4-20 Serrated (Pkg. of 10)
*	809-0070	Nut, Hex 1/4 x 20 SS
*	809-0191	Washer, Lock, 1/4-inch

\* Not illustrated.

**2.3.2 H114/117/122 Cabinet Assembly, Battered Option—Filter Ready**

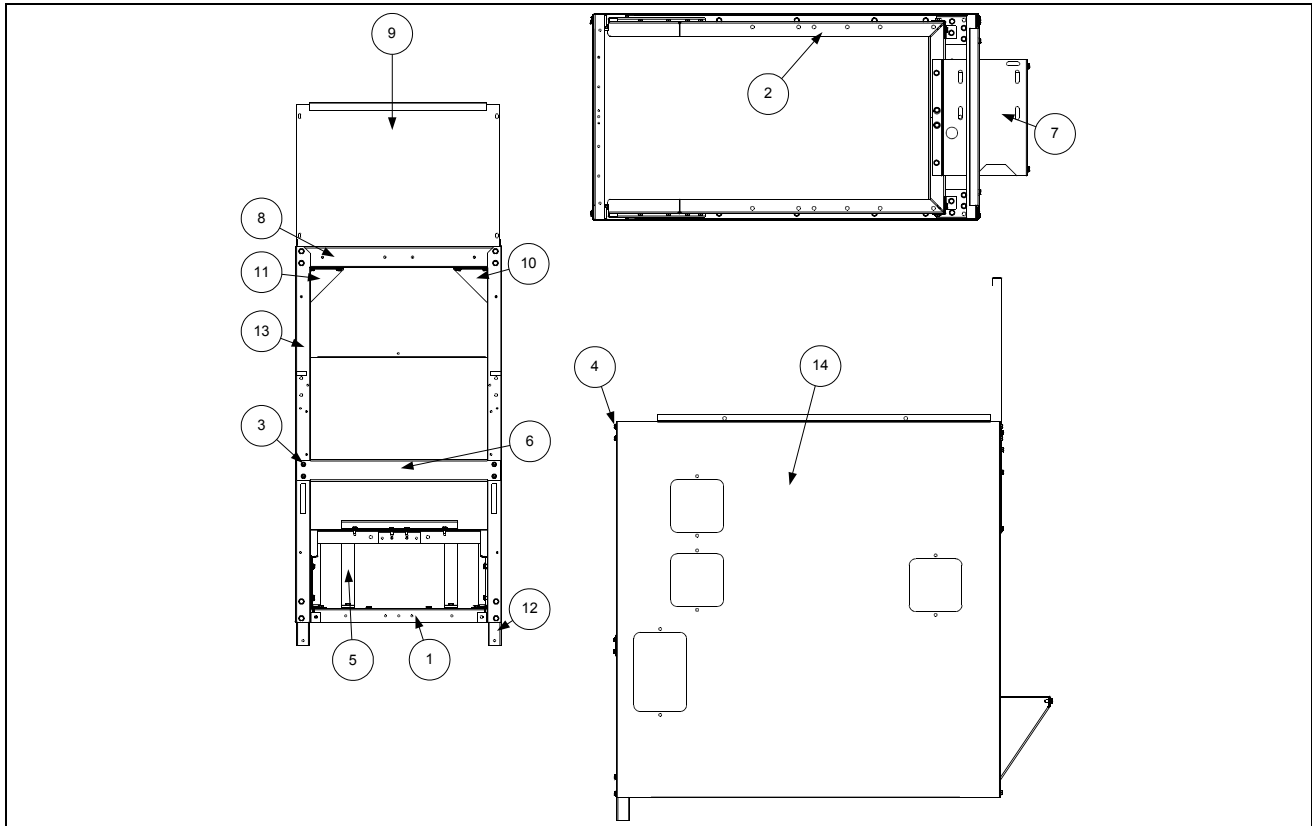

ITEM	PART #	COMPONENT
1	806-4897	Base, Single FP
2	806-5317	Filter Rail Assembly, Single FP
3	809-0361	Screw, 8 x 1/2 Hex
4	809-0412	Screw, #10-1/2 Hex
5	900-1786	Motor Mount, Cantilever Bracket
6	900-4391	Brace, Cabinet Front
7	900-4551	Motor Mount, Single FootPrint
8	900-4813	Brace, Cabinet Top Single
9	900-7448	Back, Top, FPH 50
10	901-1405	Gusset, Cabinet FP-TCF Left
11	902-1405	Gusset, Cabinet FP-TCF Right
12	910-8673	Leg, Front Filter w/Swivel Caster
13		Side, Cabinet, Left
	911-9324	Side, Stainless Steel
	901-9324	Side, Cold Rolled Steel
14		Side, Cabinet, Right
	912-9324	Side, Stainless Steel
	902-9324	Side, Cold Rolled Steel
*	910-0889	Cover, 4" x 4" S/S (for enameled steel, use 900-0889)
*	910-0890	Cover, 4" x 6" S/S (for enameled steel, use 900-0890)
*	809-0359	Screw, #8 x 1/4" Hex Washer Head

\* Not illustrated.

2.3.3 Filter Magic Under-Counter Cabinetry (after 8/2000)

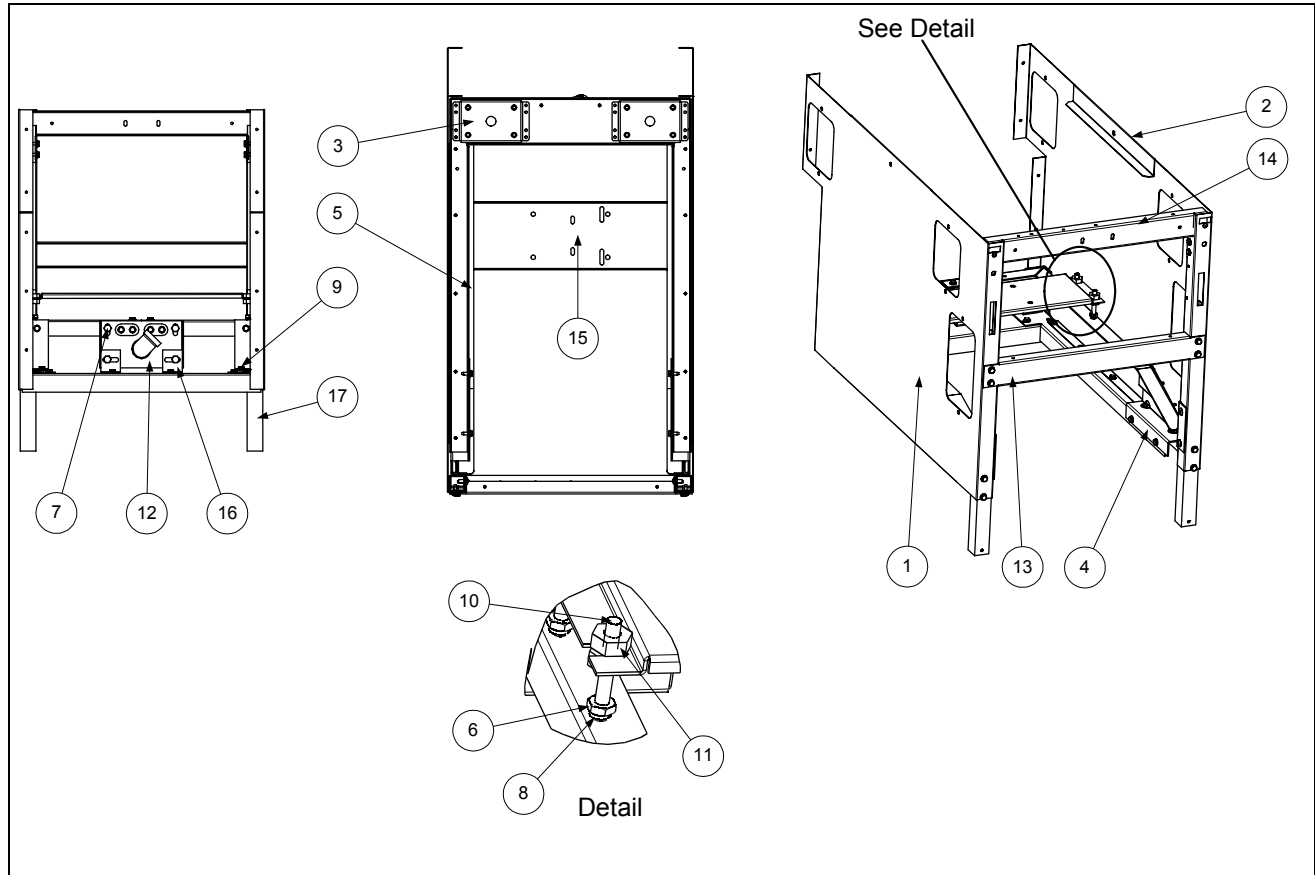

ITEM	PART #	COMPONENT
1	201-0483	Side, Cabinet U/C Enameled – Left
2	202-0483	Side, Cabinet U/C Enameled – Right
*	211-0483	Side, Cabinet U/C Stainless Steel – Left
*	212-0483	Side, Cabinet U/C Stainless Steel – Right
3	806-8059	Leg Pad Assembly
4	806-8062SP	Filter Rail Assembly, Common Electric FM
5	806-8935SP	Base Assembly, FM 3-Piece
6	826-1362	Nut, ¼ - 20 Hex (Pkg. of 10)
7	826-1389	Screw, Hex Head ¼ -20 x ¾ (Pkg. of 10)
8	809-0191	Washer, ¼ Lock
9	826-1374	Screw, #10- ½ Hex Head (Pkg. of 25)
10	809-0429	Bolt, ¼ -20 x 2
11	810-0665	Nut, Leveling
12	823-2827	Mount (Weld Assembly), Common Electric Single FP
13	900-4391	Brace, Cabinet Front
14	900-4785	Brace, Cabinet – Top and Center
15	900-8582	Mount, Motor Single FP Common Electric
16	900-8591	Bracket, Mount Common Electric Single FP
17	910-8659	Leg, Cabinet Front Common Electric Single FP

\* Not illustrated.



### 2.3.4 FootPrint III, Filter Magic II and Non-Filter Options

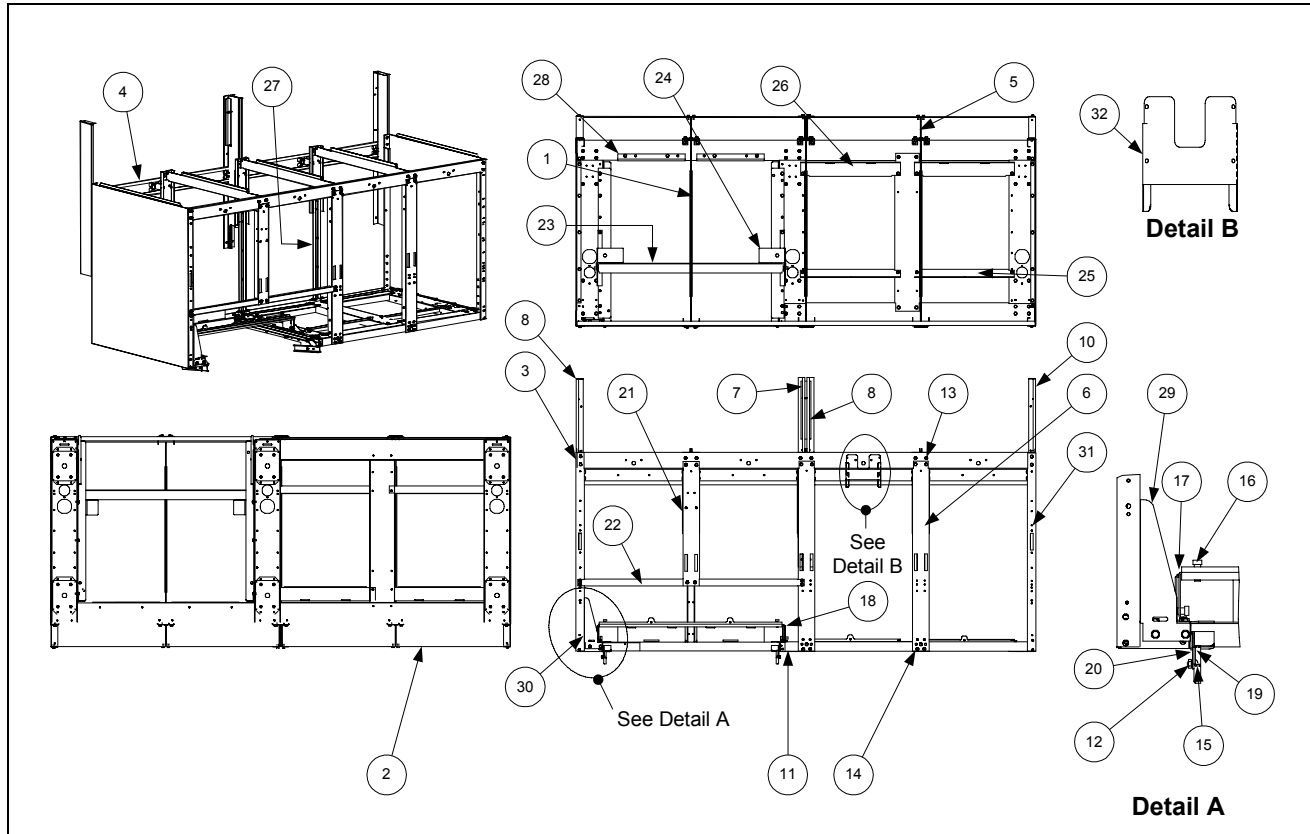

ITEM	PART #	COMPONENT
1	200-0076	Divider, Cabinet, Common Electric
2	200-0084	Brace, Rear Horizontal, 2 Battery (Quad and Double)
*	200-0085	Brace, Rear Horizontal, 3 Battery (Triple)
3	200-0091	Rail, Top- Quad Cabinet
*	200-0072	Rail, Top- Triple Cabinet
*	200-0081SP	Rail, Top- Double Cabinet
4	200-0092	Support, Rear, Common Electric
5	200-0126	Brace, Rear Support
6	200-0138	Door Post, Common Electric
7	201-0093	Enclosure, Rear Upright with Hole (Quad Only)
8	201-0137	Upright, Rear Enclosure, Common Electric
9	202-0093	Enclosure, Rear Upright with Hole (Quad Only)
10	202-0137	Upright, Rear Enclosure, Common Electric
11	806-7005SP	Base, Filter Assembly, Common Electric- Quad
*	806-6513SP	Base, Filter Assembly, Common Electric- Triple
*	806-6511SP	Base, Filter Assembly, Common Electric- Double
*	806-6997SP	Base Assembly, Common Electric N/F- Double
*	806-6999SP	Base Assembly, Common Electric N/F- Triple
*	806-7001SP	Base Assembly, Common Electric N/F- Quad
12	826-1376	Nut, 10-32 (Pkg. of 10)
13	826-1374	Screw, #10 1/2-Inch (Pkg. of 25)

Continued on following page.

ITEM	PART #	COMPONENT
14	809-0413	Spacer, Door Post (Quad and Triple Only)
15	809-0422	Screw, Shoulder- 10-32 x .40
16	809-0538	Bolt, Shoulder- ¼-20 x 3/8
17	823-2290	Front Bridge Support, Left
18	823-2291	Front Bridge Support, Right
19	900-1957	Lock Filter
20	900-1959	Bracket, Mounting, Filter Lock
21	900-2463	Post, Center Door, Common Electric
22	900-2464SP	Brace, Lower, Front Horizontal, Common Electric
23	900-2514	Bridge, Common Electric
24	900-2653	Plate, Swivel, Common Electric
25	900-2718	Brace, Contactor, Front, Common Electric w/Filter-Quad
*	200-0078	Brace, Contactor, Front, Common Electric [(w/Filter-Triple), N/F- Quad]
*	200-0075	Support, Contactor, Front, Common Electric N/F
26	900-2720	Brace, Contactor, Rear, Common Electric-Quad
*	200-0077	Brace, Contactor, Rear, Common Electric [(w/Filter-Triple), N/F- Quad]
*	200-0074	Support, Contactor, Rear, Common Electric N/F
27	900-2861SP	Support, Bottom, Common Electric
28	900-5988	Support, Rear, Bridge Filter, Common Electric
29	901-1810	Gusset, Cabinet, Left
*	902-1810	Gusset, Cabinet, Right
30	901-1948	Channel, Side Support
31	910-2456SP	Side, Cabinet – Stainless Steel, Common Electric
*	900-2456SP	Side, Cabinet – Enameled Steel, Common Electric
*	901-2843SP	Side, FM Common Electric w/Cut-out Left Cabinet, Enameled Steel
*	902-2843SP	Side, FM Common Electric w/Cut-out Right Cabinet, Enameled Steel
*	911-2843SP	Side, FM Common Electric w/Cut-out Left Cabinet, Stainless Steel
*	912-2843SP	Side, FM Common Electric w/Cut-out Right Cabinet, Stainless Steel
*	900-8451	Back, Lower Triple
*	900-8450	Back, Lower Double
*	900-5145	Back, Center Triple
*	900-5143	Back, Center Double
*	900-9635	Back, Upper Triple
*	900-9637	Back, Upper Double
32	900-9585	Heat Shield, Wire, Common Electric

\* Not illustrated.

### 2.3.5 Common Electric Filter Magic Unitary Cabinetry (after 8/2000)

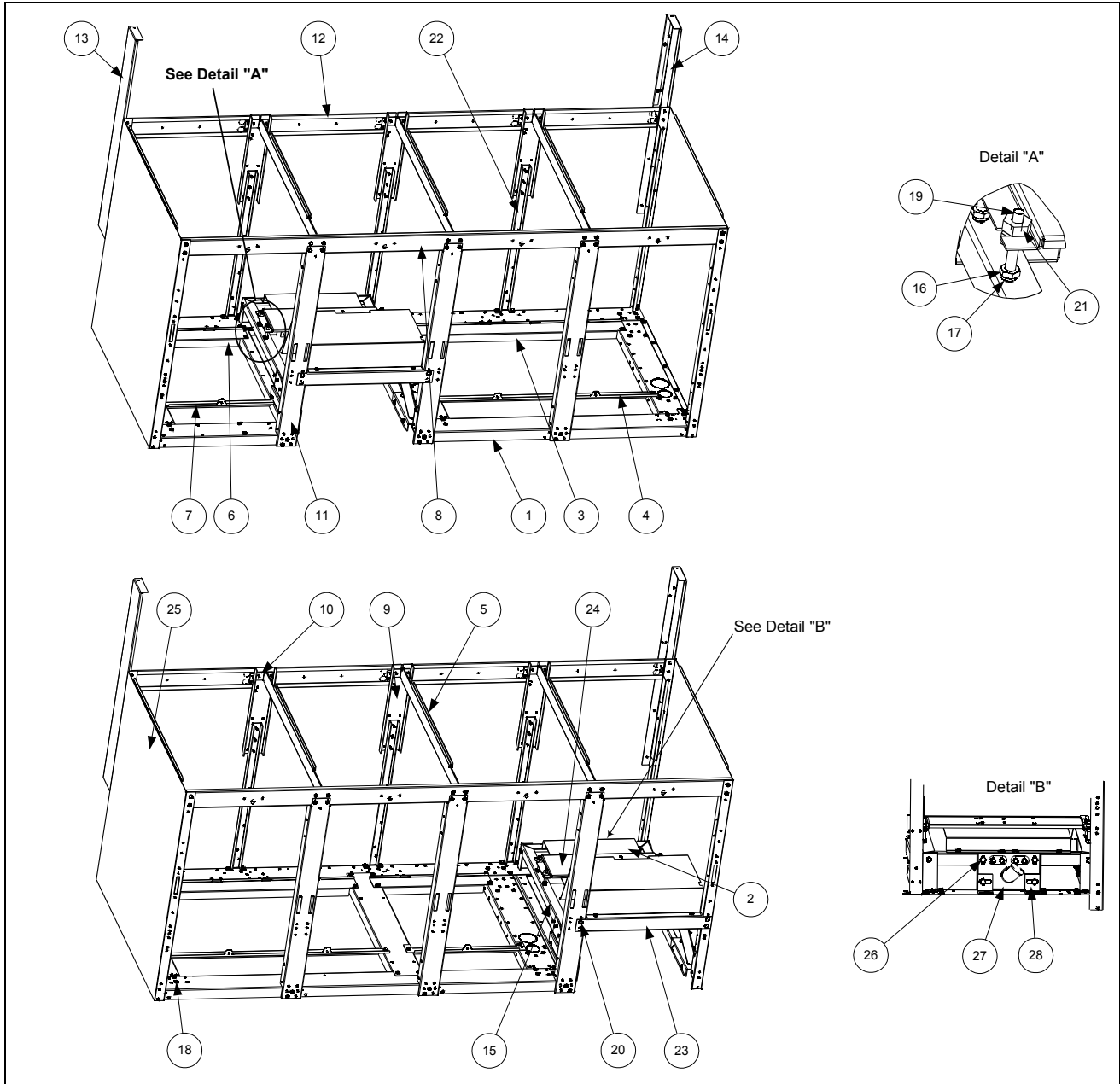

ITEM	PART #	COMPONENT
1	106-0215	Base Assembly, Quad—FM Common Electric (1F24)
*	106-0217	Base Assembly, Quad—FM Common Electric (31F2)
*	106-0218	Base Assembly, Quad—FM Common Electric (531F)
*	106-0220	Base Assembly, Quad—FM Common Electric (F246)
*	106-0214	Base Assembly, Triple—FM Common Electric (1F2)
*	106-0216	Base Assembly, Triple—FM Common Electric (31F)
*	106-0219	Base Assembly, Triple—FM Common Electric (F24)
*	106-0221	Base Assembly, Double—FM Common Electric (F2)
*	106-0222	Base Assembly, Double—FM Common Electric (1F)
2	200-0020	Shield, Filter Magic Pan CE
3	200-0074	Support, Rear Contactor Box
4	200-0075	Support, Front Contactor Box
5	200-0076	Divider, Cabinet Common Electric
6	200-0077	Brace, Rear Contactor Box
7	200-0078	Brace, Front Contactor Box Common Electric
8	200-0091	Brace (Rail), Top Quad Common Electric
*	200-0072	Brace (Rail), Top Triple Common Electric
*	200-0081SP	Brace (Rail), Top Double Common Electric
9	200-0092	Support, Rear Common Electric
10	200-0126	Brace, Rear Support
11	200-0138	Doorpost, Common Electric
12	200-0343	Brace, Rear Horizontal-Quad Common Electric
*	200-0085	Brace, Rear Horizontal-Triple Common Electric
*	200-0084	Brace, Rear Horizontal-Double Common Electric
13	201-0137	Upright, Rear Enclosure, Left, Common Electric
14	202-0137	Upright, Rear Enclosure, Right, Common Electric
15	806-8062SP	Filter Rail Assembly, Common Electric FM
16	826-1362	Nut, ¼ - 20 Hex (Pkg. of 10)
17	809-0191	Washer, ¼ Lock
18	826-1374	Screw, #10 - ½ Hex (Pkg. of 25)
19	809-0429	Bolt, ¼ - 20 x 2
20	826-1379	Screw, #10 x ½ Phillips (Pkg. of 10)
21	810-0665	Leveling Nut
22	900-2861SP	Support, Bottom Common Electric
23	900-4391SP	Brace, Cabinet Front
24	900-8582	Mount, Motor- Single FP Common Electric
25	910-2456SP	Side, Cabinet—Stainless Steel Common Electric
*	900-2456SP	Side, Cabinet—Cold Rolled Steel Common Electric
26	826-1389	Screw, Hex Head— ¼-20 x ¾ (Pkg. of 10)
27	823-2827	Mount (Weld Assembly) Common Electric Single FP
28	900-8591	Bracket, Mount – Common Electric Single FP

\* Not illustrated.

## 2.4 Casters, Legs and Associated Hardware

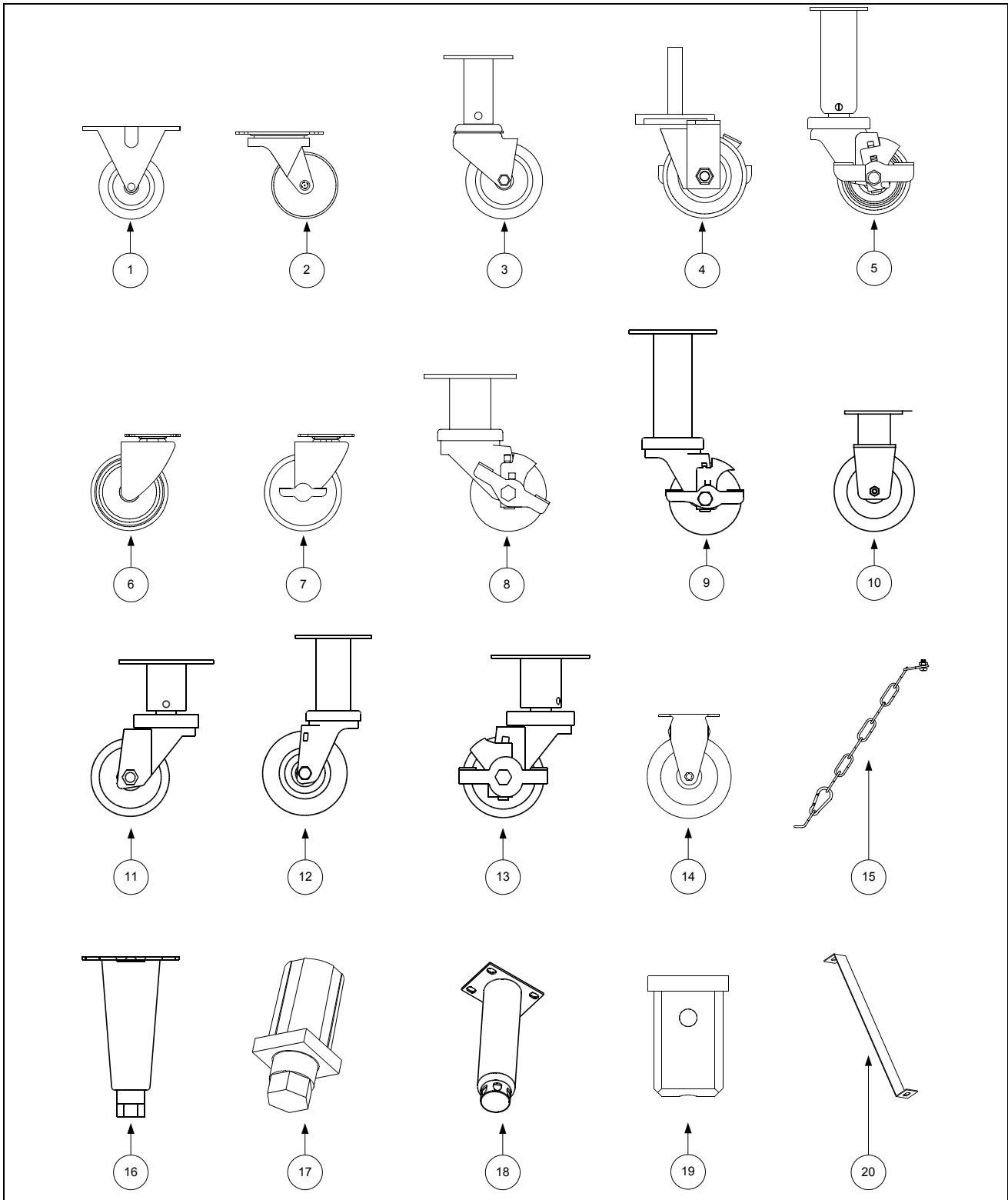

ITEM	PART #	COMPONENT
1	810-0005	Caster, Rigid
2	810-0006	Caster, Swivel-Rokite
3	810-0327	Caster, Adjustable, Without Brake
4	810-1565	Caster, Stud, Single FP 3-inch, With Lock
*	823-2844	Caster, With Brake – Single FP Electric
5	810-0944	Caster, Adjustable 3-inch With Brake
6	810-0356	Caster, 5-inch Wheel Without Brake
7	810-0357	Caster, 5-inch Wheel With Brake
8	810-0651	Caster w/Brake –FootPrint II
9	810-1239	Caster, 8.5-inch Swivel w/Brake <i>(for Cracker Barrel units, use 810-2737)</i>
10	810-1242	Caster, 8.5-inch Rigid
11	810-1367	Caster, Adjustable 3-inch w/o Brake
12	810-1494	Caster, 8.5-inch Swivel w/o Brake <i>(for Cracker Barrel units, use 810-2738)</i>
13	810-1365	Caster, Adjustable 3-inch w/Brake
14	810-0378	Caster, Stationary Rigid, 5-inch Wheel
15	826-0900	Chain Restraint Kit (for use on fryers w/casters)
16	806-3811	Leg, Package (4 per set)
17	810-0007	Leg, Adjustable (For 1 ¼-inch square tubing)
18	826-1234	Leg, Adjustable, 8.5-inch (with hardware)
19	810-1414	Insert, Square Leg, Baby FootPrint
*	910-7925	Leg ,Single FootPrint w/Caster Front Filter
*	910-1601	Leg, Square, Filter Cabinet Front
*	910-8659	Leg, Cabinet Front— Common Electric Single FootPrint
20	900-2941	Strap, Anchor—Common Electric
*	900-1835	Strap, Anchor—Single Fryers with Legs

\* Not illustrated.

## 2.5 Component Box Assemblies and Associated Hardware

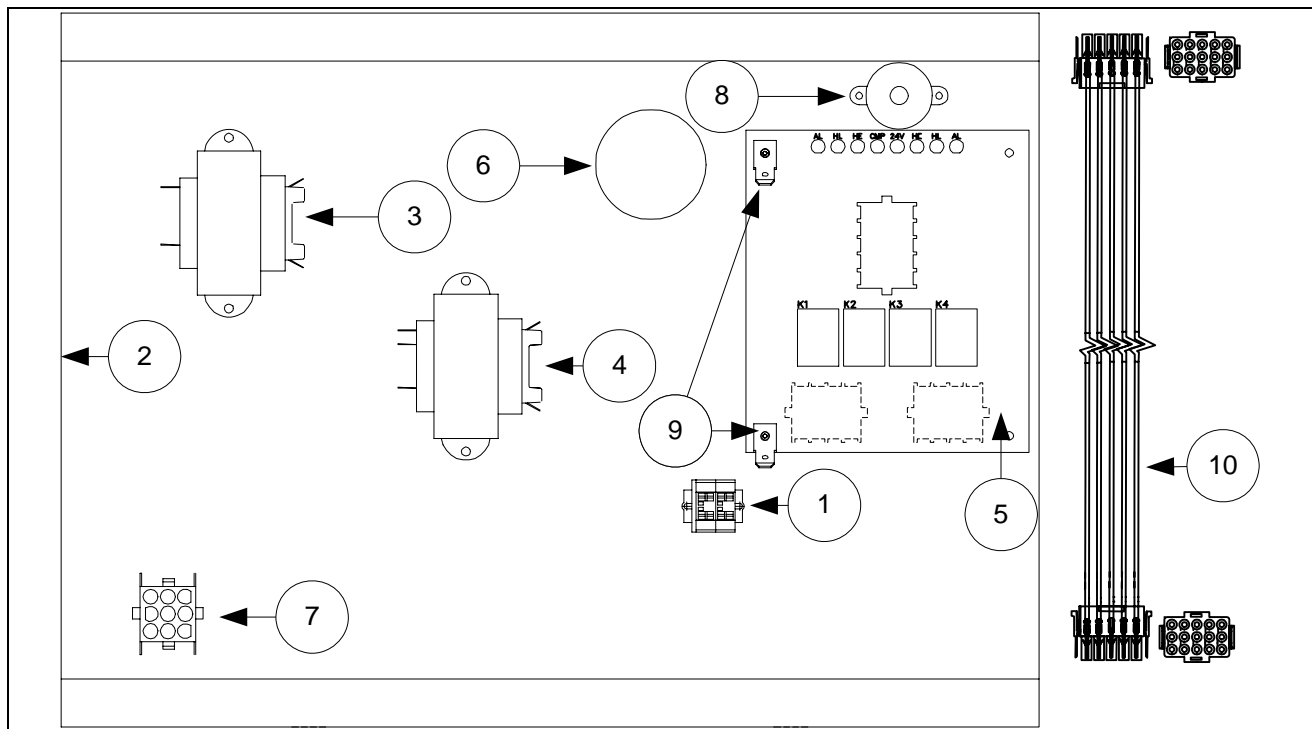

ITEM	PART #	COMPONENT
1	810-1164	Terminal Block Wire Assembly
2	806-8244	Component Box/Stud Assembly
3		Transformer, 12VAC
	807-2191	208-240 V
	807-0979	208-240V
	807-2192	100-120V
	807-0855	120V, 20VA
4		Transformer, 24VAC
	807-0680	208-240 V (without fuse)
	807-2180	208-240 V (with fuse)
	807-2181	100-120V, 62VA (with wires)
	807-0800	120V, 50VA (without wires)
*	807-1999	12/24 VAC Transformer, 208/220/230/240, 20/50 VA (Single FootPrint)
5		Interface Board
	806-6336	Standard Models
	806-3850	HE EF Models w/Rear Probe
	806-6347	Solid State (Triac) Models
	106-2982	Fast Computer
*	807-3932	Relay, Heat/Latch 12VDC SPDT 12A
6	807-1084	Bushing
7	806-6854SP	Wiring Assembly, Transformer
8	806-7179SP	Sound Device
9	826-1337	Terminal Tab (Pkg. of 5)
10	806-2071	Cable Assembly, Computer/Interface Board

\* Not illustrated.

## 2.6 Control Panel Assemblies, Doors, and Related Components

### 2.6.1 Control Panel Assemblies, Top Caps, and Associated Components

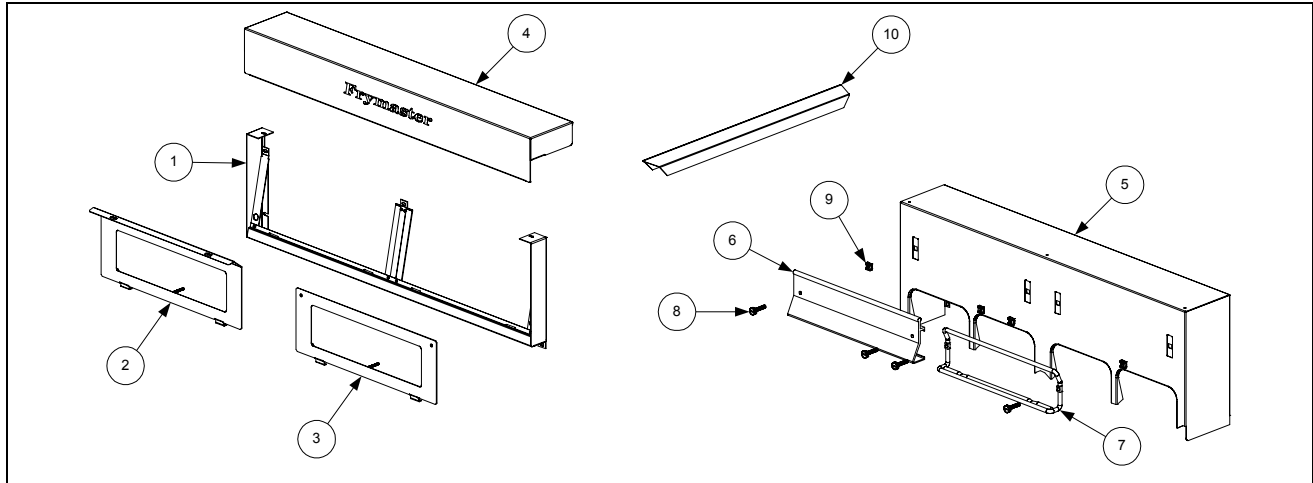

ITEM	PART #	COMPONENT
1		Control Panel Assembly
	806-7171SP	Single Fryer
	806-7172SP	Two-Fryer Battery
	806-7173SP	Three-Fryer Battery
	806-7174SP	Four-Fryer Battery
	106-2171SP	Five-Fryer Battery
	106-2324SP	Applebee's Fryer with Dump Station on Left
	106-2325SP	Applebee's Fryer with Dump Station on Right
2	823-2307	Control Panel Bezel, with Slot
3	823-0768	Control Panel Bezel, without Slots (for Digital and Analog Controllers)
4		Topcap
	106-3034SP	Single Non-Filter
	824-0409	Single FootPrint ( <i>requires Item 9 also</i> )
	106-3033SP	Double
	106-3035SP	Triple
	106-3036SP	Quad Common Electric
	824-1037	5-Battery ( <i>requires Item 9 also</i> )
	824-1047	Applebee's Fryer with Dump Station on Left ( <i>requires Item 9 also</i> )
	824-1048	Applebee's Fryer with Dump Station on Right ( <i>requires Item 9 also</i> )
5		Tilt Housing
	824-0791	Single
	824-0789	Double
	824-0798	Triple
	824-0799	Quad
	824-0852	5-Battery
6		Basket Hanger, Aluminum (No longer available, use Item 7)
7	810-1403	Basket Hanger, Wire
8	809-0171	Screw, Basket Hanger
9	826-1351	Cage Nut (Pkg. of 10) (receives Basket Hanger Screw)
10	823-1885	Top Connecting Strip



### 2.6.2 Door Assembly Components

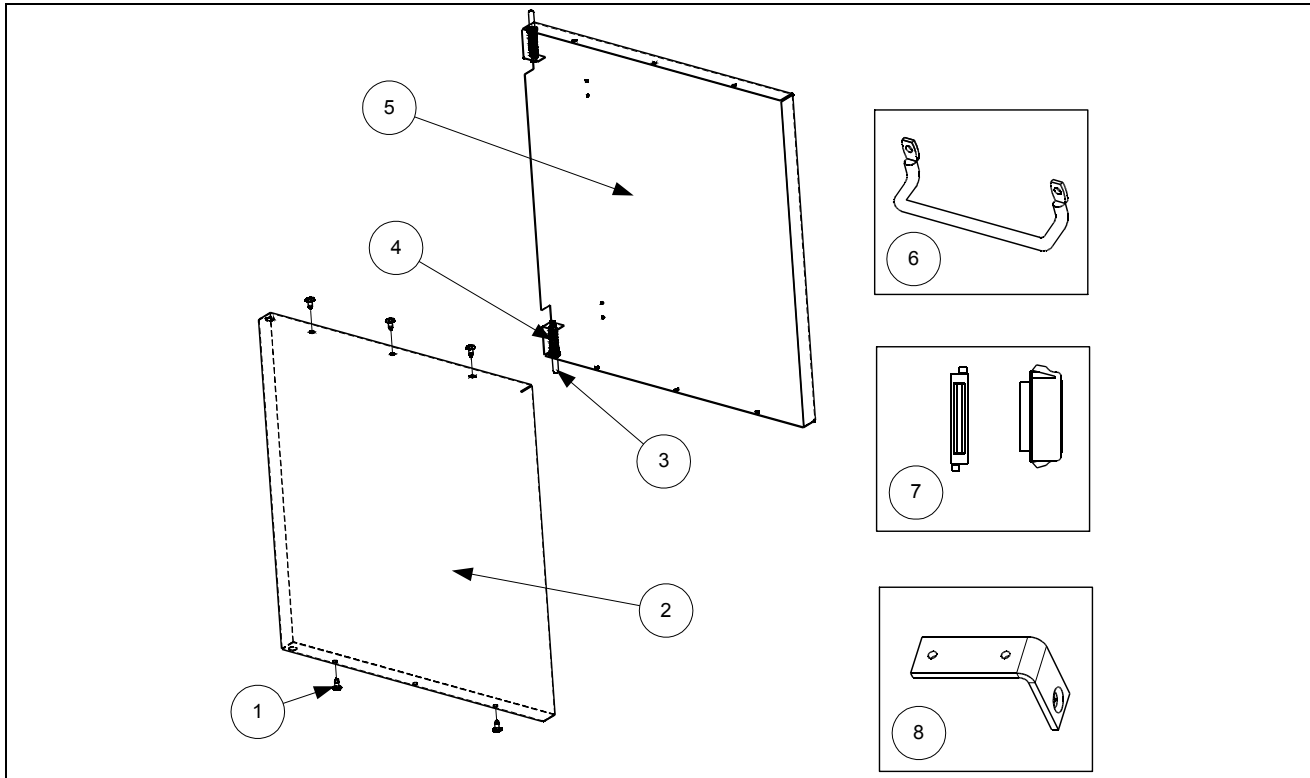

ITEM	PART #	COMPONENT
	806-6545SP	Door Assembly, Universal
1	809-0266	Screw, #10- 1/2-inch
2	824-0137SP	Panel, Door
3	806-4487SP	Door Pin Assembly
*	809-0193	Washer, Flat 1/4-Inch Nylon (Door Pin Bushing)
4	826-1343	Spring, Door Hinge (Pkg. of 10)
5	900-2485	Liner, Door
6	810-1422	Handle, Wireform, Door
7	810-1105	Magnet, Door
8	810-1508	Hinge, Universal Door

\* Not illustrated.

## 2.7 Controller Assemblies

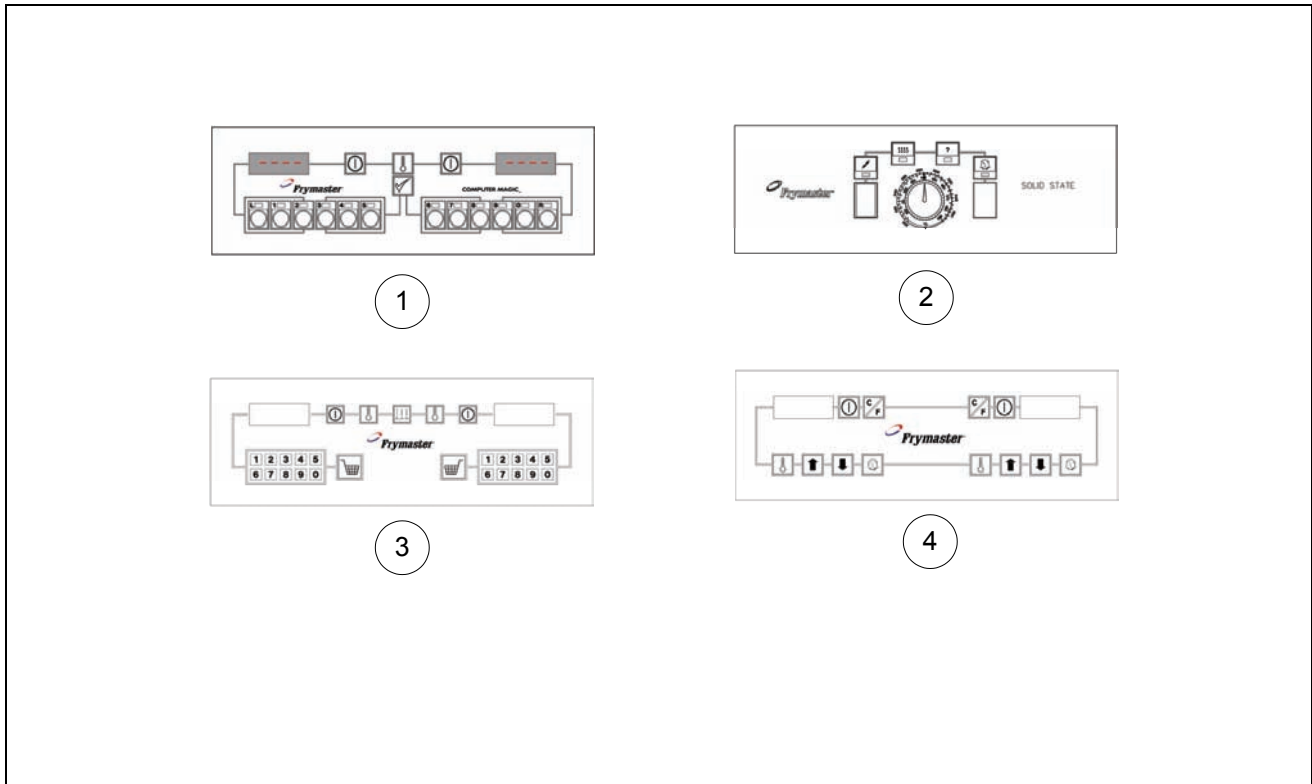

ITEM	PART #	COMPONENT
1		<b>Computer Magic III</b>
	106-1193	Full-vat (CE)
	106-1194	Dual-vat (CE)
	806-7158	Full-vat (Domestic)
	806-7159	Dual-vat (Domestic)
	806-7162	Full-vat (Triac/Solid-State)
	806-7163	Dual-vat (Triac/Solid-State)
2		<b>Analog Controller</b>
	806-7422	Full-vat
	806-7423	Dual-vat
3		<b>Basket Lift Timer</b>
	106-2090SP	Full-vat (CE)
	106-2091SP	Dual-vat (CE)
	106-2088SP	Full-vat (Domestic)
	106-2076SP	Dual-vat (Domestic)
4		<b>Digital Controller</b>
	106-1507	Full-vat (CE)
	106-1508	Dual-vat (CE)
	106-1503	Full-vat (Domestic)
	106-1952	Dual-vat (Domestic)

## 2.8 Electrical Components

### 2.8.1 Contactor Box Components, Mercury Contactor

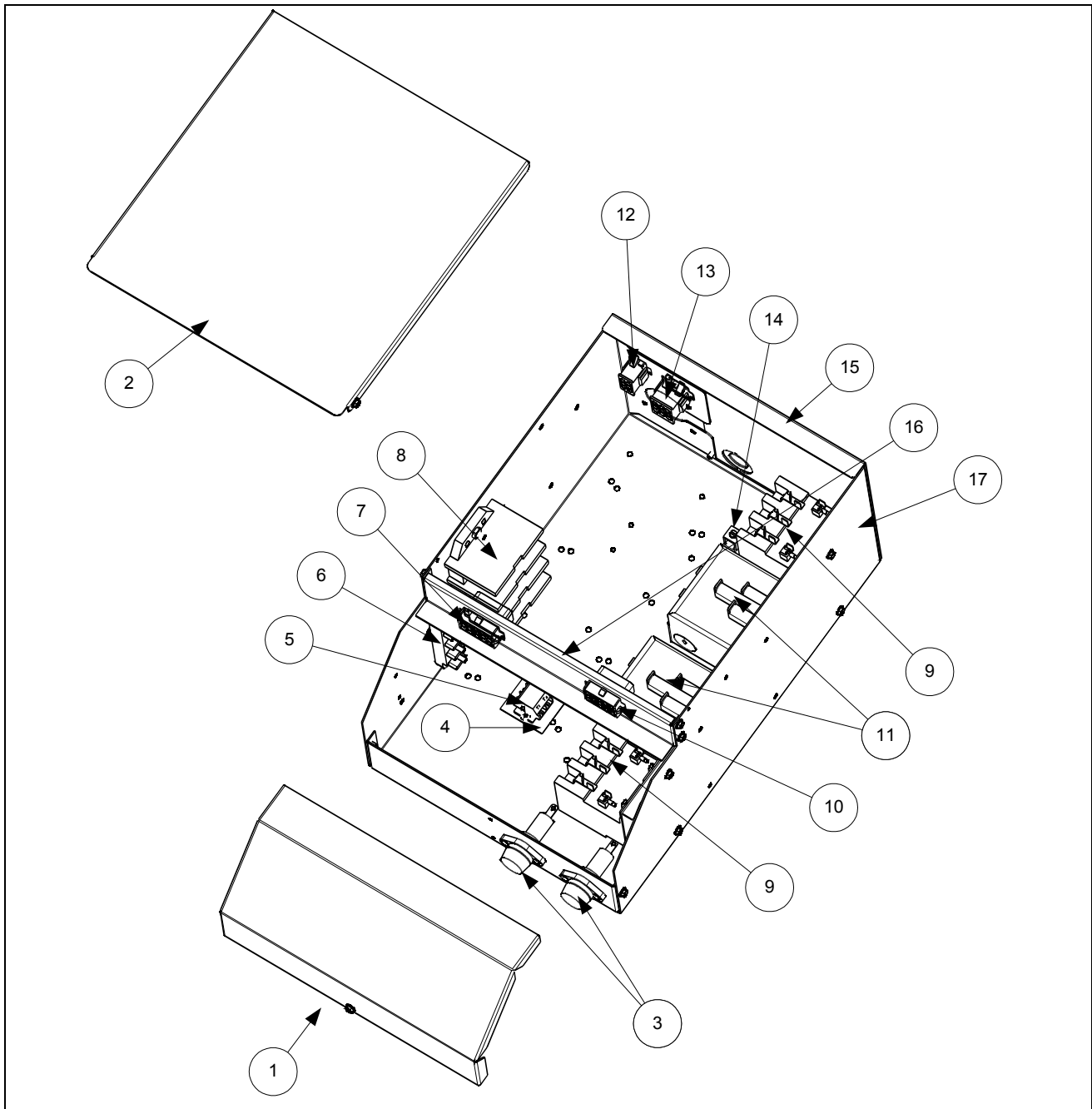

ITEM	PART #	COMPONENT
1	900-5445	Front Cover, Contactor Box
2	900-5446	Top Cover, Contactor Box
3	807-0922	Holder, Buss Fuse
*	807-2278	Fuse, 20 Amp
*	807-2279	Fuse, 15 Amp
*	807-0501	Fuse Block 3-Pole Buss (22kW)
*	807-2240	Fuse 60 Amp (22kW)
*	807-2865	Block Support, Fuse (22kW)
4	816-0217	Paper, Insulating Terminal Block (CE)
5	810-1164	Terminal Block
6	807-1973	Terminal Post
7		C1 Wiring Assembly
	806-7198SP	For Dual-vat Applications
	806-7199SP	For Full-vat Applications
8	807-2464	Power Block, Delta
*	807-2465	Power Block, WYE
9	810-1202	Contactor, 3-Pole 600V 40 Amp
10		C2 Wiring Assembly
	806-7191SP	Dual- and Full-vat
11	807-1071	Contactor, Mercury 24 VAC 30 Amp
*	807-0884	Contactor, Mercury 24 VAC 50 Amp (See <b>NOTE</b> )
12	806-7183SP	Wire Assembly, Left, Dual-vat
*	806-7186SP	Wire Assembly, Left, Full-vat
*	807-2136	Connector, 6-Pin Female
*	807-2135	Connector, 6-Pin Male
13	806-7185SP	Wire Assembly, Right (Full- and Dual-vat)
*	807-2138	Connector, 9-Pin Female
*	807-2137	Connector, 9-Pin Male
14	807-0070	Terminal, Ground Lug
15	900-5447	Back Cover, Contactor Box
16	900-5782	Bracket, Connector Common Electric
17	900-5444	Box, Contactor Common Electric

\* Not illustrated.

**NOTE:** For H22 Models using 208-240V, but not 480V.

### 2.8.2 Contactor Box Components, Solid State Relays (Triac)

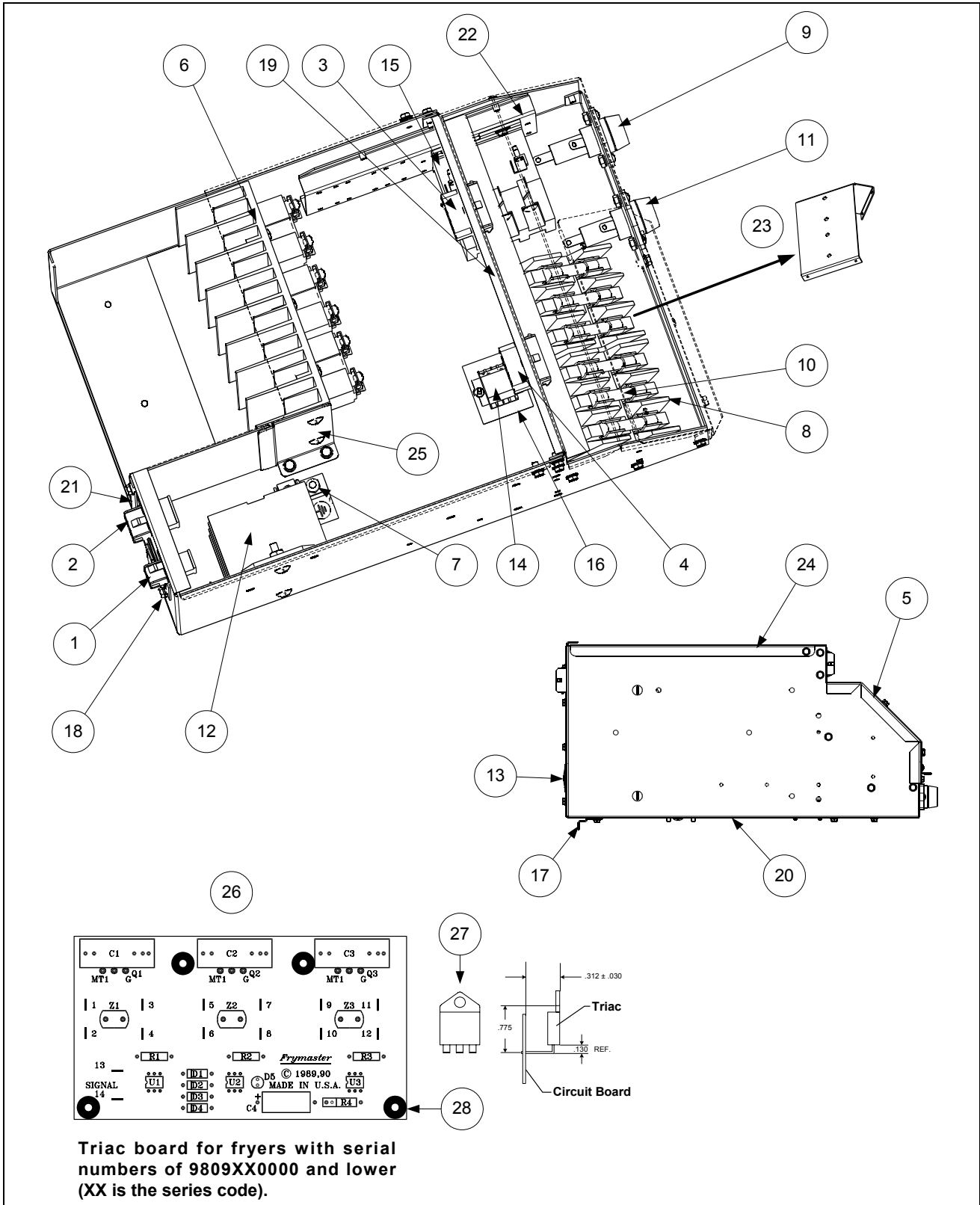

ITEM	PART #	COMPONENT
1	806-7185SP	Wire Assembly, HV Right Contactor
*	806-7184SP	Wire Assembly, HV Right FV H22 Contactor
2	806-7186SP	Wire Assembly, HV Left FV Contactor
*	806-7188SP	Wire Assembly, HV Left FV H22 Contactor
*	806-7183SP	Wire Assembly, HV Left DV Contactor
3	806-7191	C2 Wire Assembly, Common Electric
4	806-7198	C1 Wire Assembly, Dual-vat Common Electric
*	806-7199	C1 Wire Assembly, Full-vat Common Electric
5	806-8589	Front Assembly, Fuse Contactor Box Common Electric
6	806-8673	Heat Sink Assembly, Full-vat Solid State Relay
*	806-8674	Heat Sink Assembly, Dual-vat Solid State Relay
*	826-1562	Kit, 40A 280V Relay w/Heat Sink Compound
7	806-0070	Terminal, Ground Lug
8	807-0501	Fuse Block, Buss #2968 3-Pole
9	807-0922	Holder, Buss Fuse HPS
10	807-2240	Fuse, Buss 60 Amp 300 VAC
11	807-2278	Fuse, 20 Amp
12	807-2464	Power Block, Delta Common Electric
*	807-2465	Power Block, WYE Common Electric
*	806-9124	Filter Assembly (WYE Solid-State/Triac Contactor Box Only)
13	810-0743	Button, Plug 3/4-inch
14	810-1164	Terminal Block, 1 PLC Screwless
*	807-0064	Transformer-150VA, 480V Applications, w/o Basket Lift
*	807-0331	Transformer-250VA, 480V Applications, w/Basket Lift
15	810-1202	Contactor, 3-Pole 600V 40 Amp
16	816-0217	Paper, Insulating Terminal Block CE
17	900-2519	Hinge, Control Box Common Electric
18	900-2752	Plate, Cordset Common Electric
19	900-5782	Bracket, Connector Common Electric Box
20	900-5784	Box, Contactor Common Electric
21	900-5785	Rear, Triac Contactor Box Common Electric
22	900-5786	Rail, 2-Contactor Common Electric
23	900-5797	Support, Fuse Block Common Electric
24	900-5895	Top, Triac Contactor Box Common Electric
25	900-8239	Rear, Split Triac Contactor Box
26	806-5072	Triac Board Assembly (2 required for Dual-vat Applications)
*	812-1283	Heat Sink, Triac Board
27	807-1276	Triac 600/40A TO-218
*	815-0554	Heat Sink Compound (required for installing Triac Board to Heat Sink)
28	807-1337	Standoff, Triac Board

\* Not illustrated.

### 2.8.3 Elements and Related Components

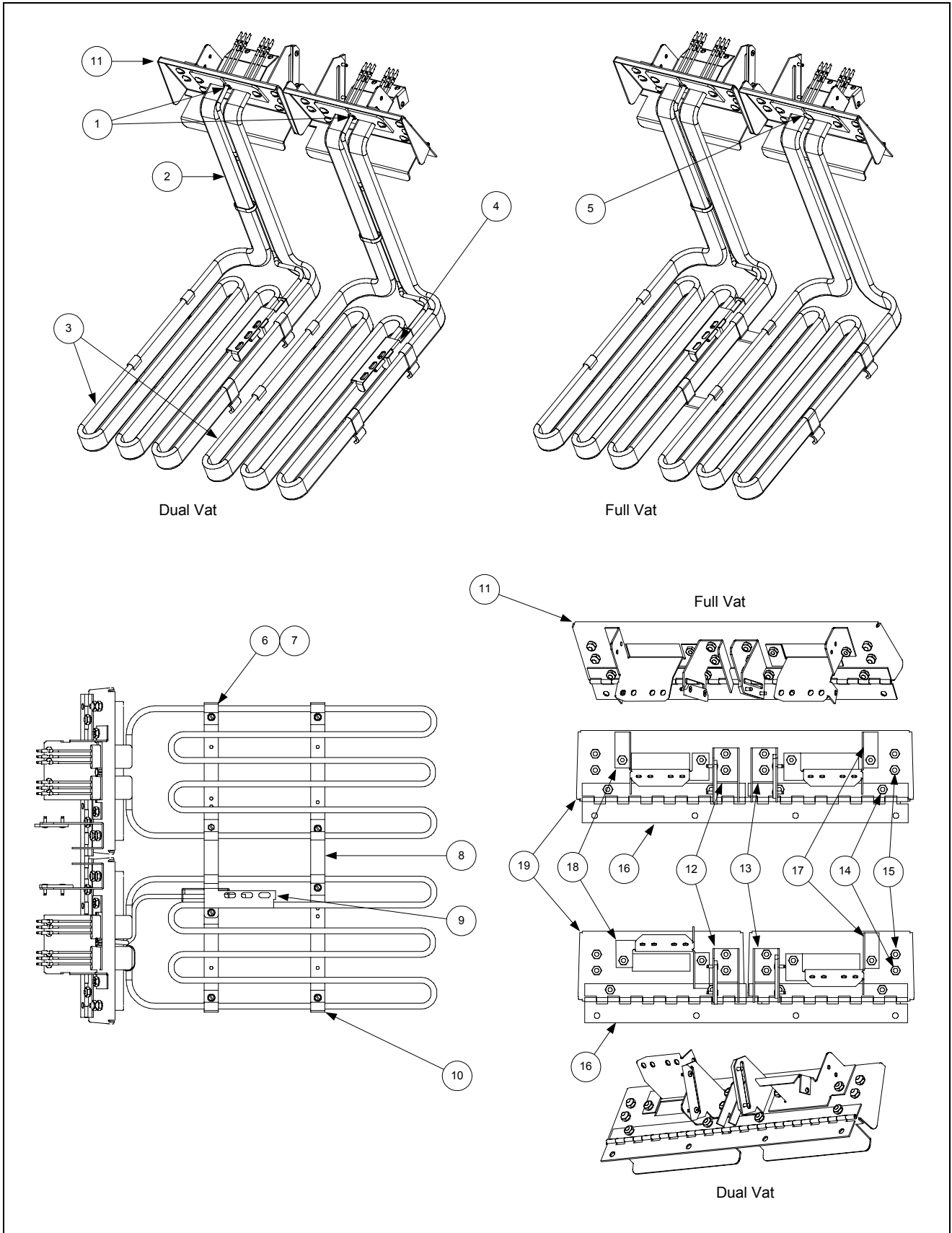

ITEM	PART #	COMPONENT
1	826-1339	Bushing, .375 Split (Pkg. of 10)
2	809-0567	Ty-Wrap, Metal
3		Heating Element
	807-2639	208V 7 kW
	807-2640	208V 8.5 kW
	807-2641	220V 8.5 kW
	807-2642	230V 7 kW
	807-2643	230V 8.5 kW
	807-2644	240V 7 kW
	807-2645	240V 8.5 kW/ 220V 7 kW
	807-2646	200V 8.5 kW
	807-2647	380V 7 kW
	807-2648	380V 8.5 kW
	807-2649	440V 7 kW
	807-2650	440V 8.5 kW
	807-2651	480V 7 kW
	807-2652	480V 8.5 kW
	807-2653	400V 8.5 kW
	807-3171	220V 11 kW
	807-3172	230V 11 kW
	807-3173	240V 11 kW
	807-3174	200V 11 kW
	807-3175	380V 11 kW
	807-3176	440V 11 kW
	807-3177	480V 11 kW
	807-3178	400V 11 kW
	807-3237	208V 11 kW
*		Heating Element Assemblies
	806-3141SP	208V, 14kW Full-vat
	806-3142SP	240V 7kW Dual-vat
	806-8474SP	240V 14 kW Full-vat
	806-7887SP	230V H22, Dual-vat
	806-8497SP	440V H14/17, Full-vat
	806-8677SP	In-N-Out 208V 22kW
4	807-2478	Temperature Probe
5	816-0480	Dome Plug, .375 OD. (Full-vat Only)
6	809-0518	Screw #8 32 x 3/8-inch
7	910-2042	Clamp, Element
8	910-3681	Element Support, Full-vat
*	910-5214	Element Support, Dual-vat
9	910-5022	Bracket, Temperature Probe
10	910-5213	Clamp, H14/H17 Element
11	106-0003SP	Tilt Plate Assembly, Full-vat
*	106-0004SP	Tilt Plate Assembly, Dual-vat
12	106-0573SP	Spring Slot Bracket Assembly, Right
13	106-0572SP	Spring Slot Bracket Assembly, Left
*	810-0297	Spring, Element (14 and 17kW only)

Continued on following page.



ITEM	PART #	COMPONENT
*	810-1546	Spring, Element (22kW only)
		Tilt Plate Assembly, Individual Components
14	826-1330	Screw, 10-32 x 3/8 (Pkg. of 25)
15	826-1376	Nut, 10-32 (Pkg. of 10)
16	810-0035	Hinge, Stainless Steel Split—14-Inch
17	901-8509	Bracket, Element Support, Left
18	902-8509	Bracket, Element Support, Right
19	910-9640	Plate, Tilt, Full-vat (1 Required)
19	910-9641	Plate, Tilt, Dual-vat (2 Required)
*	826-1061	Tilt Switch, Mercury Non-CE (Full-Vat requires one switch and Dual-Vat requires two.)
*	826-2228	Tilt Switch, CE (Full-Vat requires one switch and Dual-Vat requires two.)

\* Not illustrated.

**THIS PAGE INTENTIONALLY LEFT BLANK**

## 2.9 Filter Base/Pan Assemblies

### 2.9.1 Filter Base Assemblies and Components, FootPrint III

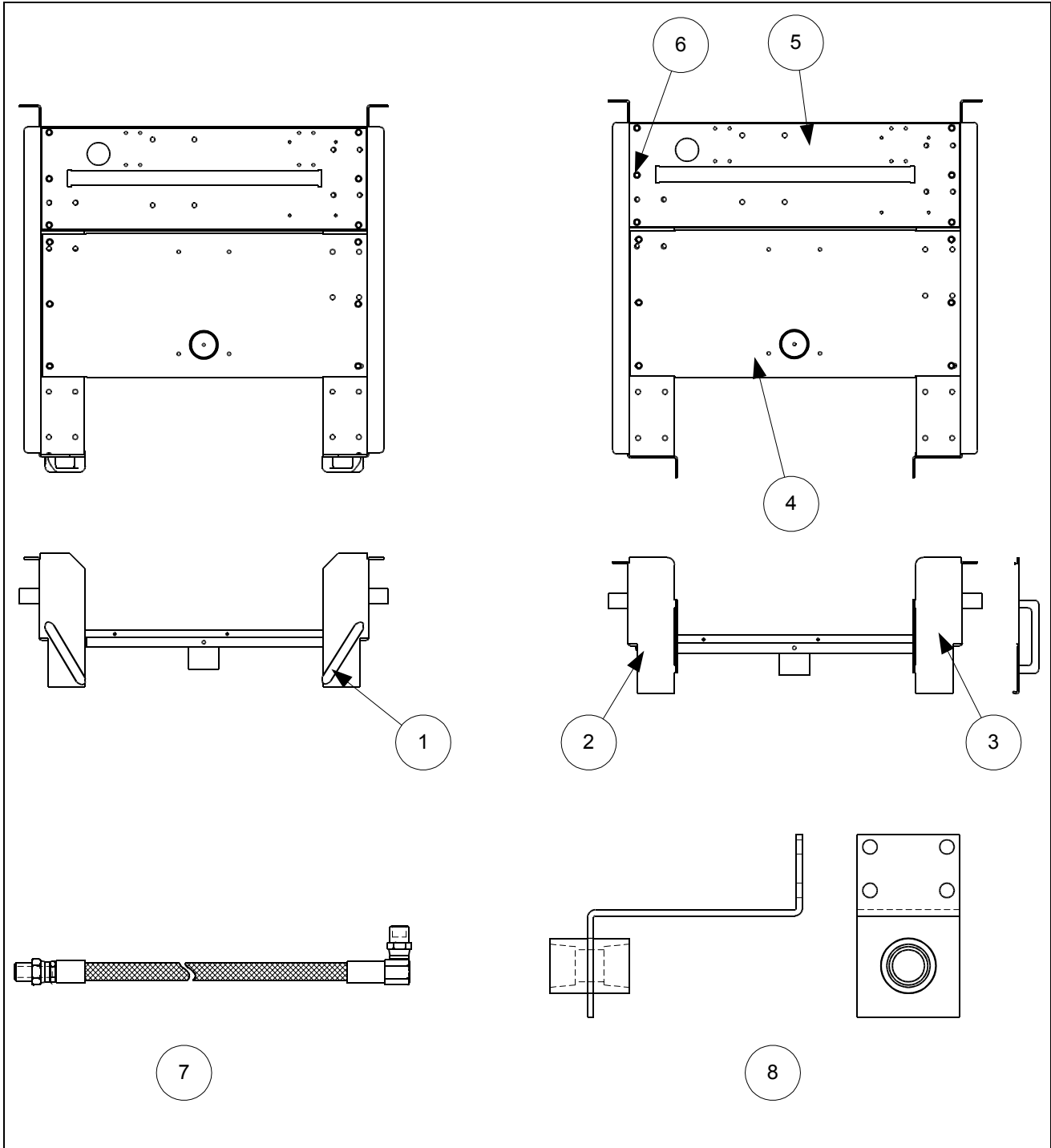

ITEM	PART #	COMPONENT
	806-8648SP	Filter Base Assembly, FootPrint III (After 8/97)
	806-5985SP	Filter Base Assembly, FootPrint III w/Casters (Before 8/97)
1	810-0180	Handle, Filter Base Assembly
*	826-1360	Screw, #10-24 x 5/16 [Pkg. of 25 (to attach P/N 810-0180)]
2	901-8542	Filter Base, Left Side
3	902-8542	Filter Base, Right Side
4	823-2289	Filter Pan Support
5	900-5396	Motor Support
6	826-1374	Screw, #10-1/2 Hex Head (Pkg. of 25)
*	900-5477	Cover, Motor (August 1997 and later)
*	824-0558	Cover, Motor (Prior to August 1997)
*	900-1949	Standoff, Filter Wiring Box
7	810-1423	Hose, Oil Return
8	823-2638	Bracket, Oil Return Hose

\* Not illustrated.

**NOTE:** Item 1 (P/N 810-0180 Handle, Filter Base Assembly) is available as a replacement for damaged handles on base assemblies manufactured from 8/97 to 8/99. If damaged filter bases need replacement, they must be replaced with P/N 901-8542 and 902-8542, which include handles. Filter bases with replaceable handles are no longer available.

### 2.9.2 Filter Pan Assemblies, Single FootPrint and FootPrint III

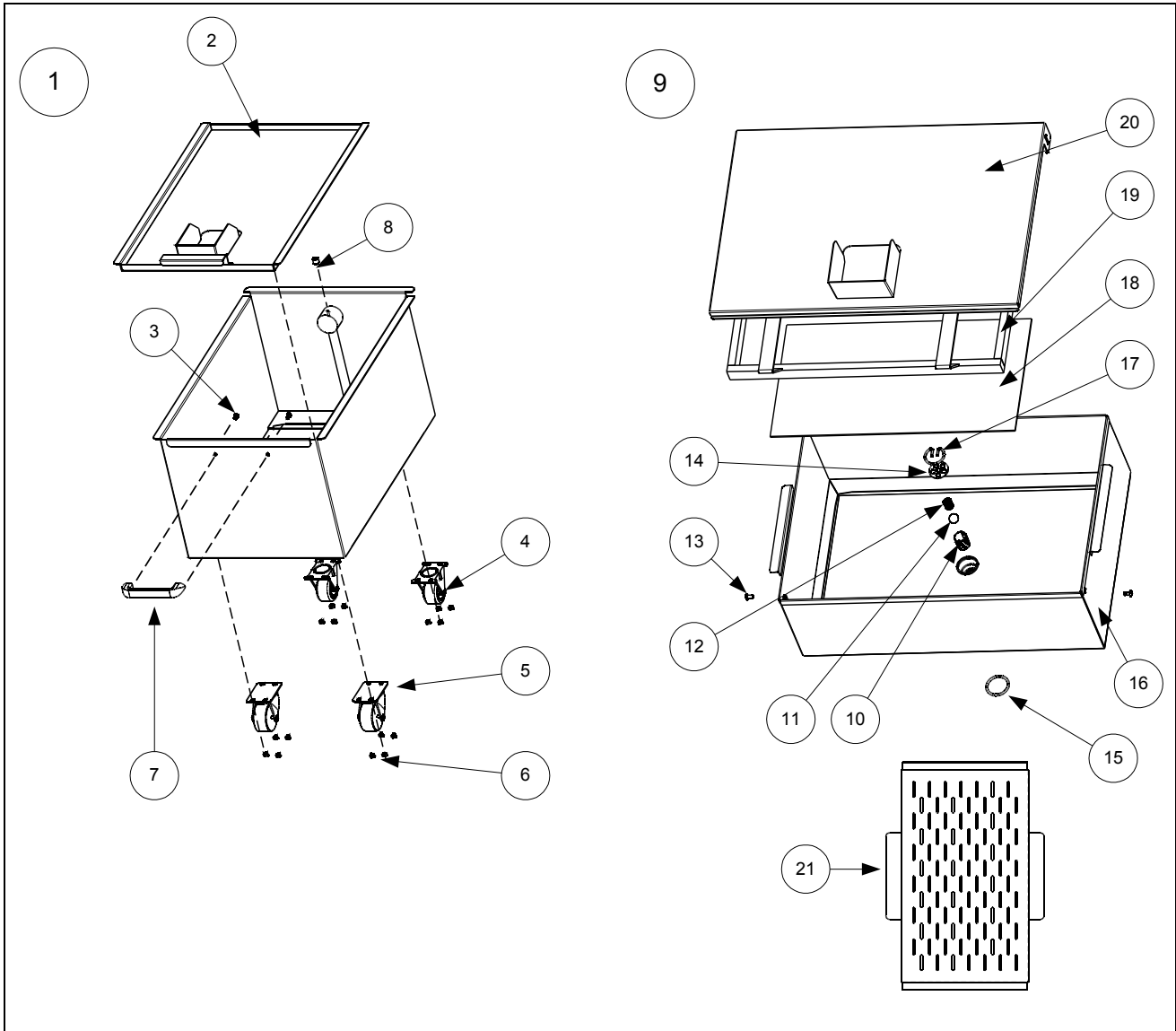

ITEM	PART #	COMPONENT
1	806-9546SP	Filter Pan Assembly, Single FootPrint [See Section 2.9.3 Filter Magic II (Before 2/99)] for filter screen, crumb screen and other inner-pan components)
*	823-2828	Filter Pan
2	806-9547SP	Cover Assembly, Filter Pan
*	809-0045	Nut, 10-32
*	809-0117	Screw, 10-32 x 3/8 SS
*	809-0185	Washer, Flat #10
*	910-1816	Handle, Filter Pan, Single FootPrint
3	826-1360	Screw, 10-24 x 5/16 (Pkg. of 25)
4	810-0005	Caster, Rigid
5	810-0006	Caster, Swivel
6	826-1376	Nut, 10-32 (Pkg. of 10)
7	810-0180	Handle, Door
8	813-0411	Plug, Pipe-1/8 Internal Hex
9	806-5618SP	Filter Pan Assembly, FootPrint III
10	810-1388	Tube, Check Valve
11	810-0948	Ball, Check Valve
12	810-0946	Spring, Check Valve
13	809-0422	Screw, Shoulder 10-32 x 7/16
14	900-5448	Strain Plate, Check Valve
15	816-0181	O-Ring, Check Valve
16	823-1979SP	Filter Pan
17	810-1387	Retainer, Check Valve
18	900-8819	Screen, Filter
19	810-1405	Hold-down Ring
20	823-2027	Cover, Filter Pan
21	824-0430	Screen, Crumb
*	826-1490	Kit, Filter Pan Check Valve Service (Items 10, 11, 12, 14, 15, and 17)

\* Not illustrated.

### 2.9.3 Filter Pan Assemblies, Filter Magic II (Before 2/99)

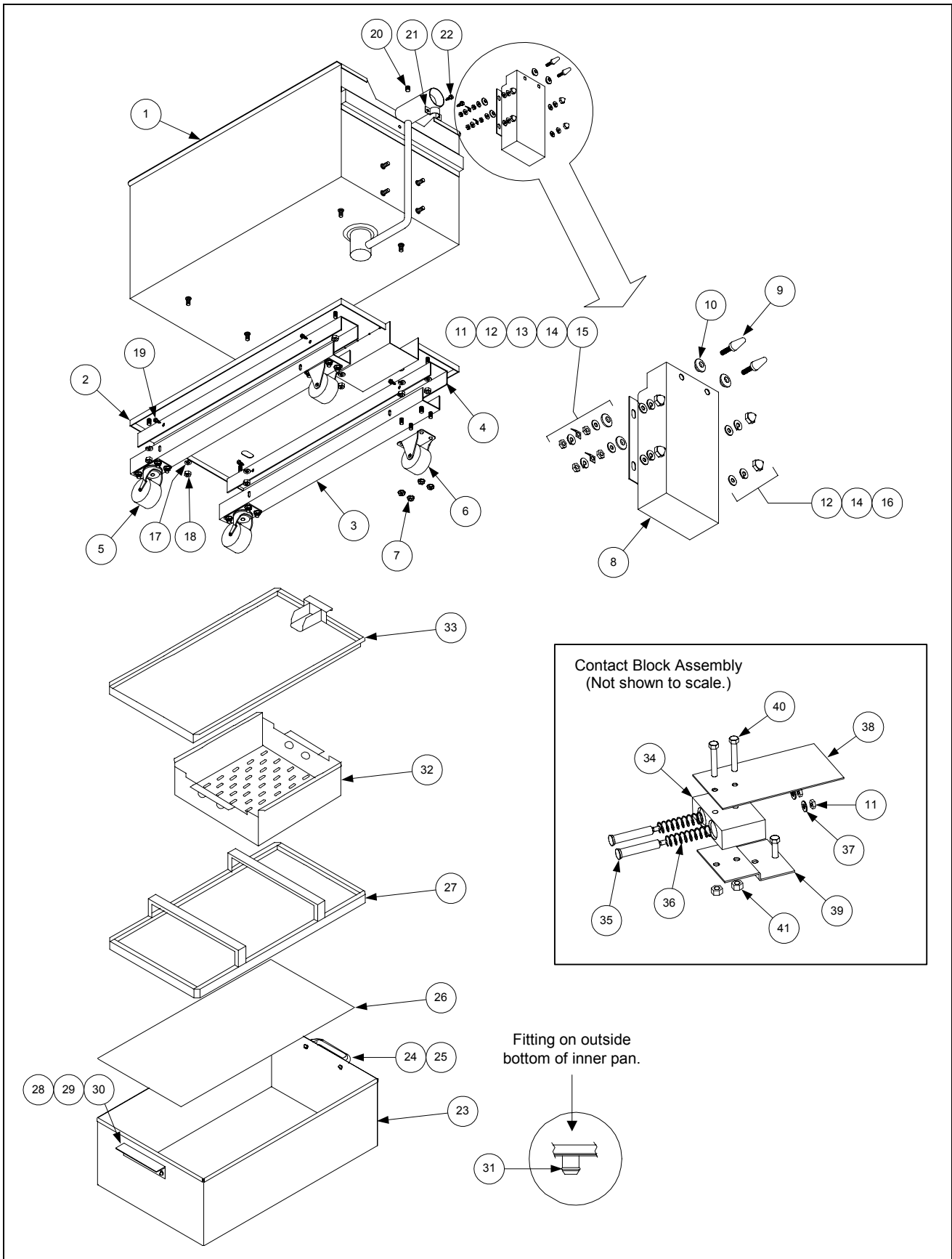

ITEM	PART #	COMPONENT
	<b>806-7411SP</b>	<b>Outer Pan Assembly (Includes Items 1-22)</b>
1	823-1360SP	Outer Pan
2	823-2332	Base, Filter Pan Assembly
3	806-9471	Channel, Caster Mounting
4	900-2805	Channel, Caster Lift Base
5	810-0006	Caster, Swivel
6	810-0005	Caster, Rigid
7	826-1376	Nut, 10-32 Hex Keps (Pkg. of 10)
8	824-0291	Cover, Suction Tube
9	810-0695	Contact, Pan
10	807-1270	Washer, Insulated Shoulder
11	809-0053	Nut, 10-32 Hex
12	809-0184	Washer, #10 Lock
13	826-1337	Tab, Terminal (Pkg. of 5)
14	809-0185	Washer, #10 Flat
15	807-1367	Washer, Non-Conductive Flat
16	809-0020	Nut, 10-24 Cap
17	809-0189	Washer, 1/4-inch Flat
18	826-1362	Nut, 1/4-20 Hex (Pkg. of 10)
19	826-1374	Screw, #10 X 1/2-inch Hex Washer Head (Pkg. of 25)
20	813-0411	Plug, 1/8-inch Hex Head Pipe
*	806-4373	Heater Strip Assembly, 24V 25W
*	811-0861	Insulation, Foam (Heater Strip)
*	811-0746	Tape, Aluminum (50-yard Roll)
*	810-0441	Clamp, Heater (Aluminum)
21	910-1350	Clamp, Suction Tube
22	826-1371	Screw, #8 X 1/2-inch Hex Head Drill Point (Pkg. of 25)
	<b>806-5282SP</b>	<b>Inner Pan Assembly (Includes Items 23-31)</b>
23	823-1731SP	Inner Pan
24	810-0180	Handle, Filter Pan
25	809-0024	Screw, 10-24 X 5/16-inch Slotted Round Head
26	900-8827	Screen, Filter (SanaGrid)
27	810-1406	Ring, Hold Down
28	910-1366	Handle, Filter Pan
29	809-0117	Screw, 10-32 X 5/16-inch Slotted Truss Head
30	809-0045	Nut, 10-32 Hex Cap
31	816-0117	O-Ring
32	824-0416	Screen, Crumb
33	823-1390	Cover, Filter Pan
	<b>806-4694SP</b>	<b>Contact Block Assembly (Includes Items 11 and 34-41)</b>
34	810-0694	Block, Contact
35	810-0693	Pin, Contact
36	810-0696	Spring, Contact Pin
37	809-0185	Washer, #10 Flat
38	816-0126	Insulator, Contact Block
39	900-1521	Bracket, Contact Block
40	809-0291	Screw, 1/4-20 X 1.5-inch
41	826-1372	Nut, 1/4-20 Hex Grip (Pkg. of 10)

\* Not Illustrated.



### 2.9.4 Filter Pan Assembly, Filter Magic II One-Piece

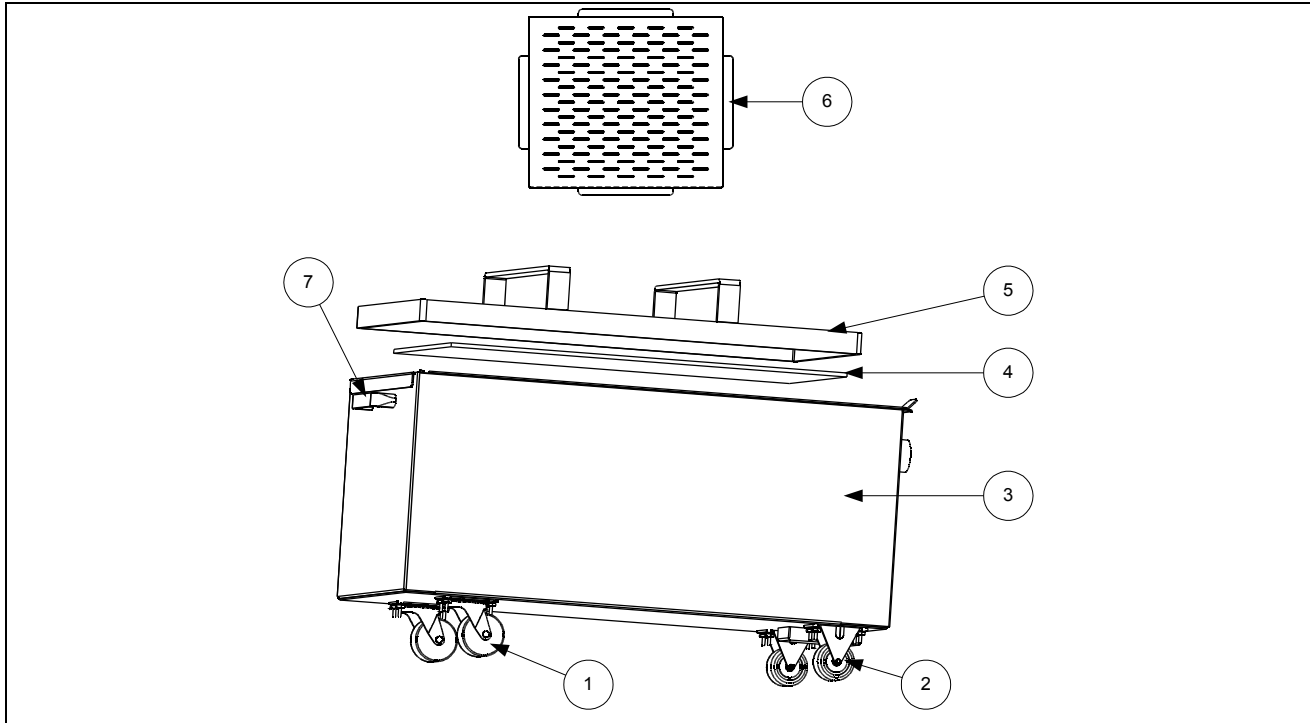

ITEM	PART #	COMPONENT
		Complete Pan Assemblies
	106-0361SP	After July 2000
	806-9449SP	Between March 1999 and July 2000
	106-0090SP	Carl's Jr. w/Magnasol Filter
1	810-0006	Caster, Swivel
2	810-0005	Caster, Rigid
3		Pan, Filter
	823-2828SP	Used with Filter Pan Assembly 106-0361SP
	823-2751SP	Used with Filter Pan Assembly 806-9449SP
	823-2951SP	Used with Filter Pan Assembly 106-0090SP
4		Screen, Filter (SanaGrid)
	900-8933	Used with Filter Pan Assembly 106-0361SP
	900-8827	Used with Filter Pan Assembly 806-9449SP
5		Ring, Hold Down
	823-2899	Used with Filter Pan Assembly 106-0361SP
	810-1406	Used with Filter Pan Assembly 806-9449SP
6	824-0416	Screen, Crumb
7	810-0180	Handle, Filter Pan
*	826-1360	Screw, 10-24 X 5/16-inch Slot Head

\* Not illustrated.

## 2.10 Filter Pump and Motor Assemblies and Associated Hardware.

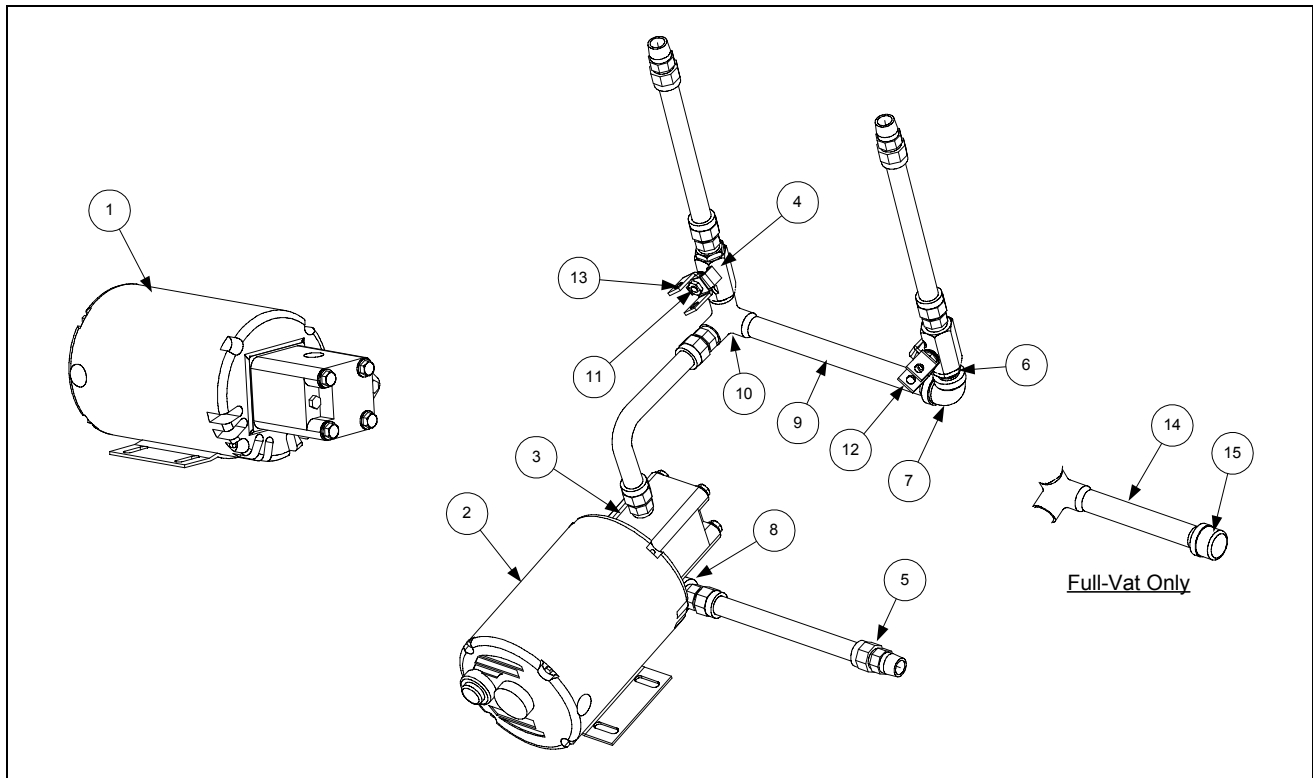

ITEM	PART #	COMPONENT
1		Pump and Motor Assembly (Illustration Purposes Only)
2	826-1270	Motor and Gasket Kit, 230V-250V 50/60 Hz
*	826-1756	Motor and Gasket Kit, 208V 50/60 Hz
*	826-1712	Motor and Gasket Kit, 100V-115V 60 Hz
3	826-1264	Kit—Pump and Gasket
*	807-1995	Pump, Viking 4 GPM
*	809-0514	Cap Screw, 5/16-18 Hex Head
*	809-0194	Washer, Flat 5/16-inch
*	816-0093	Gasket, Pump/Motor
4	810-0278	Gemini Valve w/o Handle
5	810-1067	Flex Line, Oil Return, 11-inch
6	813-0022	Nipple, 1/2-inch x Close (Dual-vat Configuration)
7	813-0062	Elbow, 1/2-inch 90° (Dual-vat Configuration)
8	813-0165	Elbow, 1/2 x 1/2-inch 90° Street
9	813-0253	Nipple, 1/2 x 10-inch (Dual-vat Configuration)
10	813-0331	Elbow, 1/2-inch, With Side Outlet
11	900-2935	Nut, Retainer; Oil Return Valve
12	901-2772	Handle, Valve, Rear Flush Left (Dual-vat Configuration)
13	902-2772	Handle, Valve, Rear Flush Right
14	813-0098	Nipple, 1/2 x 6.5-inch
15	813-0469	Cap, Pipe 1/2-inch

\* Not illustrated.

## 2.10 Filter Pump and Motor Assemblies and Associated Hardware (cont.)

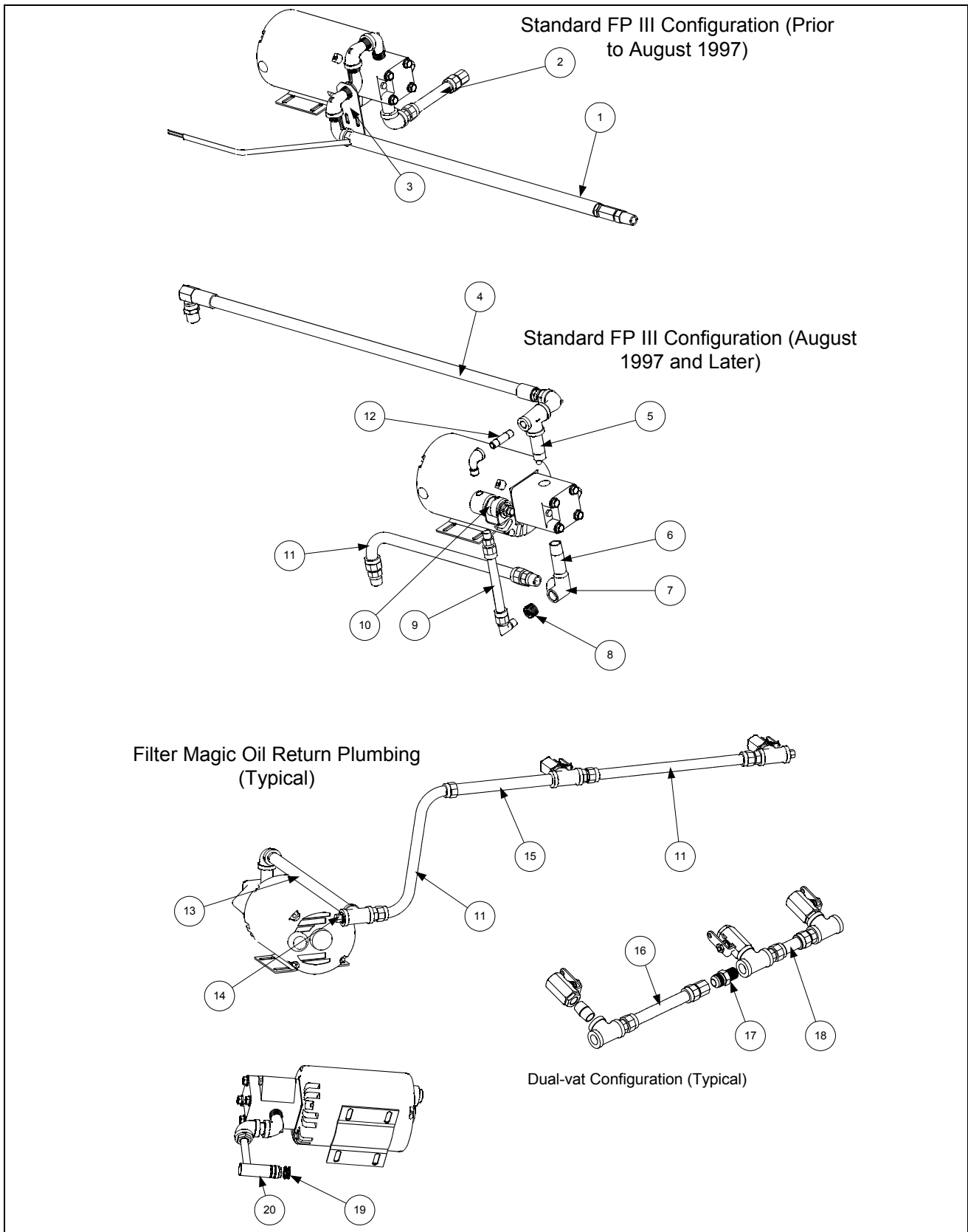

ITEM	PART #	COMPONENT
1		<b>Hose, Heated Oil Return</b>
	810-0945	120VAC
	810-1037	208-250VAC
2	810-1159	Flexline, 7½-inch (19cm) Oil Return
3	900-1958	Support, Oil Return
4	810-1404	Flexline, Oil Return (pump to rear manifold)
5	813-0265	Nipple, ½-inch x 2 ½-inch
6	813-0460	Nipple, ½-inch x 3-inch
7	813-0331	Elbow, ½-inch 3-way
8	813-0304	Bushing, ½-inch to ¼-inch Reducer
9	810-1373	Flexline, Pump Bypass
10	807-2484	Valve, Solenoid Vent
11	810-1057	Flexline, 15½-inch (39.4 cm) Oil Return
12	813-0537	Nipple, ¼-inch x 2-inch
13	813-0368	Nipple, ½-inch x 16-inch
14	813-0156	Pipe Plug, ½-inch
15	813-0275	Nipple, ½-inch x 9-inch
16	810-1488	Flexline, 7-inch (17.8 cm) Oil Return
17	810-1668	Adapter, ½-inch, Female to Female (Used with Item #11, #16 and #18)
18	810-1160	Flexline, 5½-inch (14 cm) Oil Return
19	826-1392	O-Ring (2 required) (Pkg. of 5)
20	823-1356	Disconnect Fitting
*	816-0102	Grommet, Disconnect Fitting
*	900-1472	Diverter, Oil
*	910-1627	Bracket, Disconnect Fitting Support
*	826-1668	Kit, 100V-120V Heater Tape Replacement
*	826-1669	Kit, 108V-250V Heater Tape Replacement
*	811-0746	Aluminum Tape
*	811-0861	Foam Tape
*	811-0208	Spaghetti Insulation

\* Not illustrated.

### 2.10.1 Filter Pump Boxes and Components

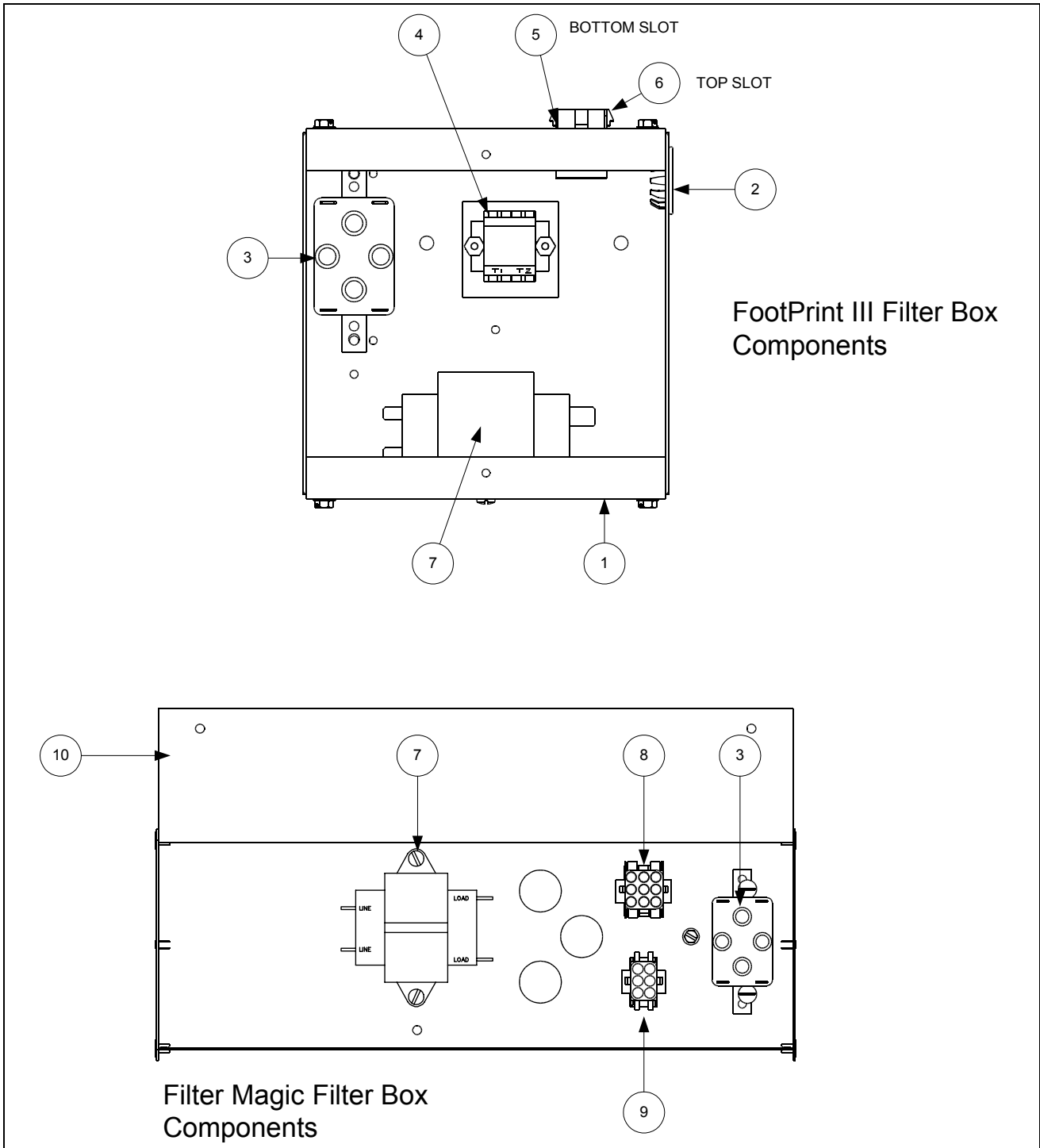

ITEM	PART #	COMPONENT
1	900-5250	Box, Filter FP III
2	810-0044	Plug Button .875, #SS48155 K1110
3		Relay
	807-2434	18A 1/3 HP 24V Coil (before 09/2000)
	807-0012	18A 1/3 HP 24V Coil (after 08/2000)
4	810-1164	Terminal Block, 1 PLC Screwless
*	810-1168	Terminal, Block Screwless End (230V, 50 Hz Filter Magic)
*	807-0276	Block, UL Male 12 Pin Terminal
*	816-0217	Paper, Insulating Terminal Block CE
5	806-7494	Plug Assembly, FPIII Non-Reversing
6	806-8021	Plug Assembly, Filter Box
7		Transformer
	807-0800	120V/24VAC, 50/60 Hz, 50VA
	807-0680	208/240/24VAC, 50/60 Hz, 43VA
	807-1238	105V/24VAC, 50/60 Hz, 50VA
	807-2176	100/120VAC – 12/24V
	807-1999	208/250VAC – 12/24V
8	806-6203	Wiring Assembly, Filter Magic, 9-Pin
9	806-6204	Wiring Assembly, 6-Pin
10	900-2250	Box, Control, Filter Magic
*	900-2251	Box, Control, Filter Magic, Under Cabinet
*	200-0410	Box, Control, Filter Magic Common Electric
*	200-0409	Box, Control, Filter Magic, Common Electric, Under Cabinet
*		<b>Heater Tape Assemblies, FootPrint and Filter Magic</b>
	806-9245SP	120V 25W, 36-inch
	806-5932SP	240V 45W, 36-inch
	806-5933SP	120V 25W, 18-inch
	806-5934SP	240V 25W, 18-inch
*		<b>Heater Tape Assemblies, FootPrint 56-inch</b>
	806-6730SP	100V 40W
	806-6731SP	120V 40W
	806-6732SP	240V 70W
	806-6733SP	250V 70W
*		<b>Harness and Wire Assemblies</b>
	807-2862	FootPrint III Filter Cable (2-pin, 9-pin, and 15-pin connectors)
	WIR0146SP	230V/50Hz Filter Box
	WIR0010SP	120V Standard Filter Control
	WIR0250SP	Filter Control Box
	WIR0394SP	CE Filter Box

\* Not illustrated.

## 2.11 Drain System Components

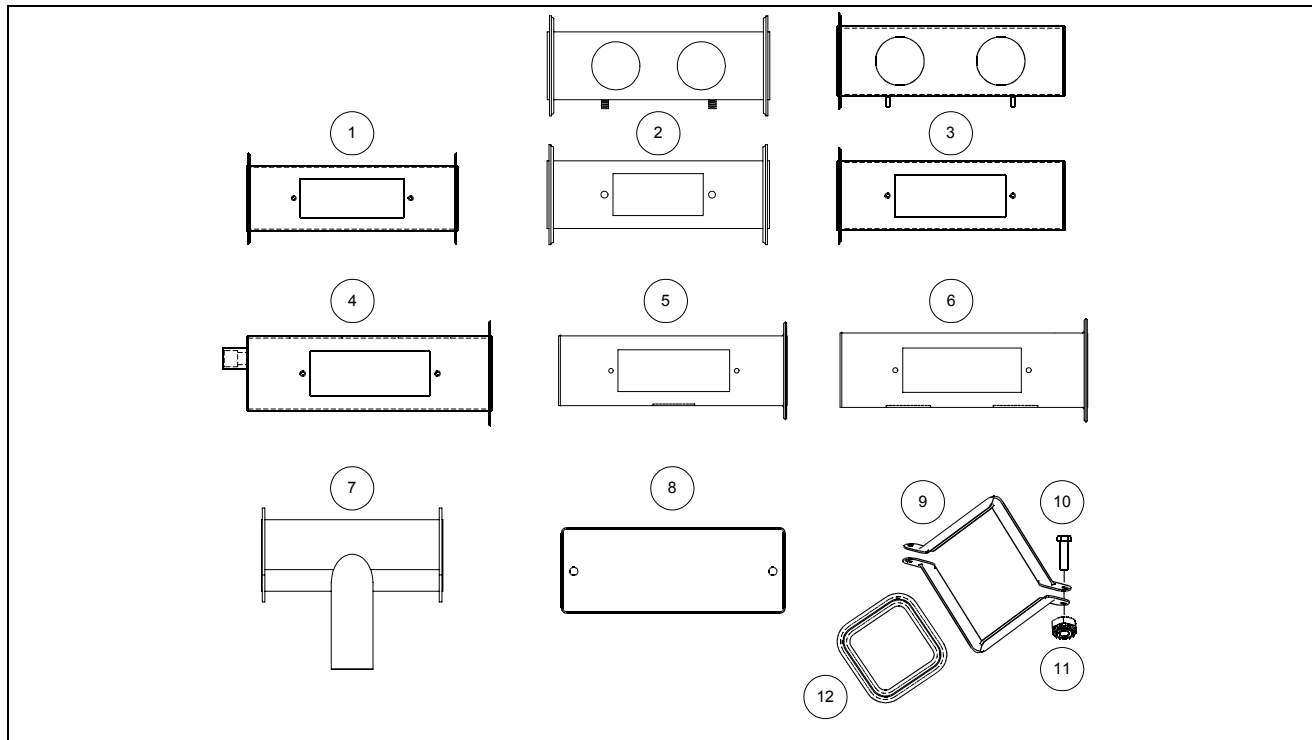

ITEM	PART #	COMPONENT
1	823-0718	Drain Tube, Left End, 2.5 x 8.0-inch
2	823-0725	Drain Tube, Left End, Dual-vat, 2.5 x 8.0-inch
3	823-1551	Drain Tube, Right End, Dual-vat
4	823-2636	Drain Tube, Left End, Dual-vat
*	823-2637	Drain Tube, Left End, Full-vat
5	823-1549	Drain Tube, Right End, Full-vat
6	823-1543	Drain Tube, Right End, Dual-vat
*	823-1508	Drain Tube, Right End, Full Vat 15.5-inch
*	823-0724	Drain Tube, Dual-vat FM 15.5-inch
*	823-0717	Drain Tube, FM Standard Cabinet 15.5-inch
*	823-0720	Elbow, Drain-EF Right FM
*	823-0721	Elbow, Drain-EF Left FM
7	823-2336	Drain, FootPrint
8	826-1348	Cover, Drain Cleanout (Pkg. of 5)
*	816-0021	Gasket, Drain Cover
*	826-1382	Wingnut, Drain Cover (Pkg. of 10)
*	816-0092	Grommet, 1" Drain
*	826-1345	Washer, Drain Nut (Pkg. of 25)
*	809-0347	Drain Nut
9	810-0396	Clamp, 2.5-inch Drain, Filter Magic (Two Required Per Union)
10	826-1375	Screw, 10-32 x 3/4 Hex Trim HD SS (Pkg. of 5)
11	826-1376	Nut, 10-32 Hex (Pkg. of 10)
12	816-0032	Gasket, Square Drain

\* Not illustrated.

## 2.12 Filtration System Components

### 2.12.1 Oil Return Plumbing Assemblies and Components

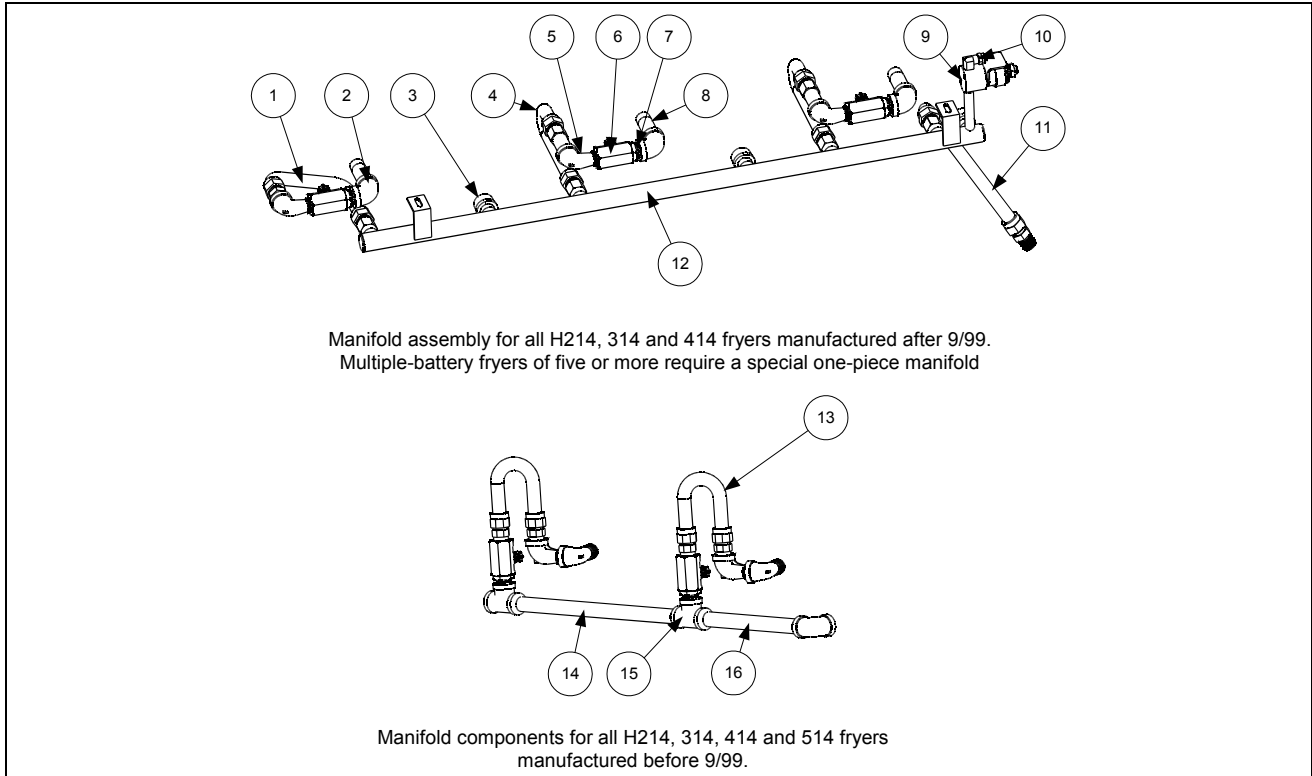

ITEM	PART #	COMPONENT
1	106-0002SP	Flex Line Assembly, With Male/Female Ends
2	813-0062	Elbow, 1/2-inch 90°
3	813-0469	Cap, Pipe 1/2-inch
4	106-0054SP	Flex Line Assembly, With Female Ends
5	813-0165	Elbow, Street, 1/2 x 1/2-inch 90°
6	810-0278	Gemini Valve, Without Handle
7	813-0022	Nipple, 1/2-inch Close NPT
8	813-0265	Nipple, 1/2 x 2.5-inch NPT
9	807-2484	Vent Valve, Solenoid 1/4-inch NPT
*	826-1720	Vent Tube, Teflon 3/8-inch OD. X 2-foot
10	810-1372	Fitting, 90°, 1/4-inch NPT: 3/8 Tube (includes ferrule and end nut)
11	806-9439SP	Flex Line Assembly, 14-inch with Male/Female Ends
12	810-1517	Manifold, Oil Return, RF H314/17/22
*	810-1516	Manifold, Oil Return, RF H214/17/22
*	810-1518	Manifold, Oil Return, RF H414/17/22
13	810-1067	Flex Line, Oil Return, 11-inch
14	813-0509	Nipple, 1/2 x 14.5-inch NPT
15	813-0003	Tee, 1/2 x 1/2 x 1/2-inch
16	813-0275	Nipple, 1/2 x 9-inch NPT
*	813-0093	Nipple, 1/2 x 4-inch NPT

\* Not illustrated.



### 2.12.2 Power Shower and P.S. Oil Return Manifold Assemblies

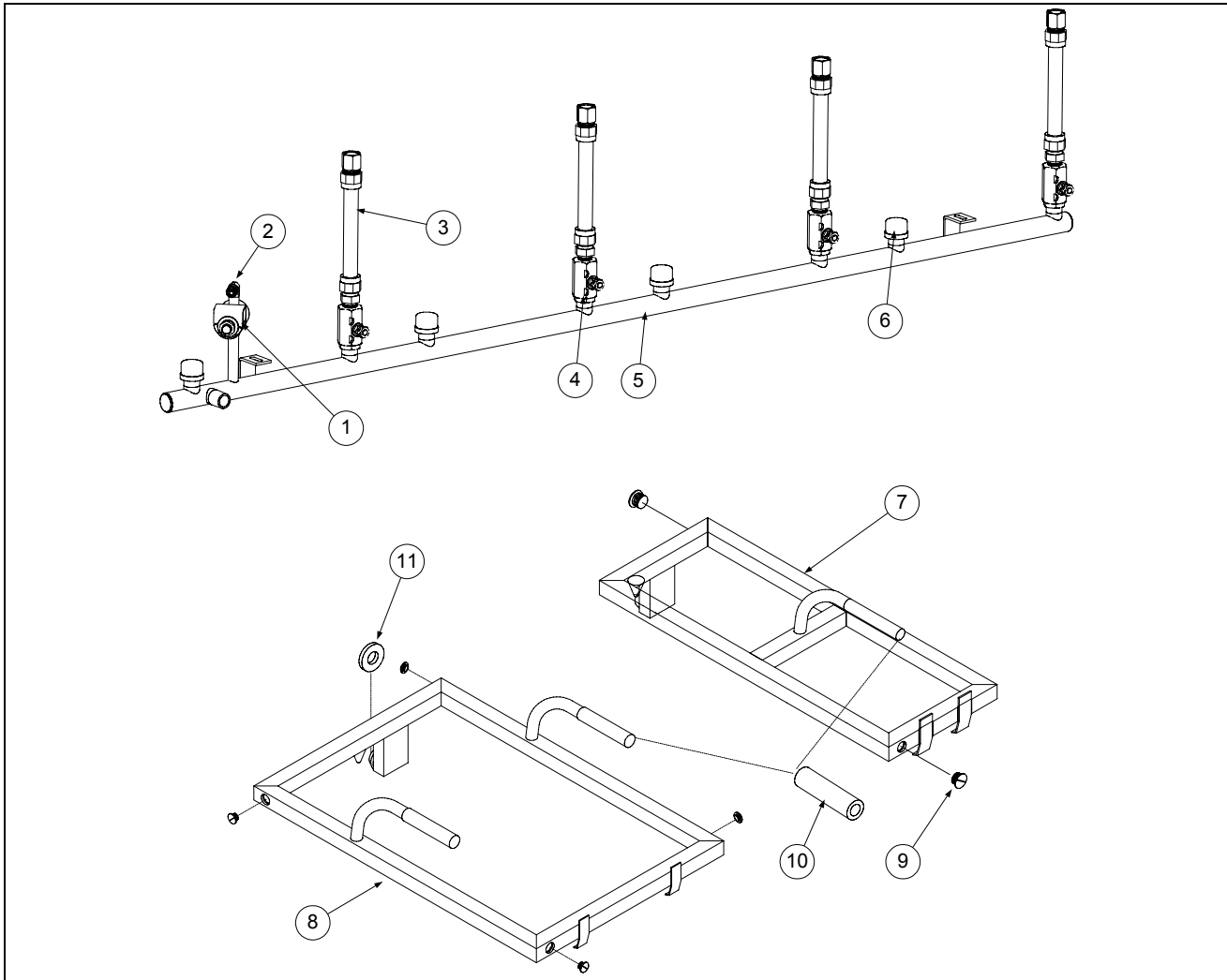

ITEM	PART #	COMPONENT
1	807-2484	Vent Valve, Solenoid ¼ NPT
2	810-1372	Fitting, 90 Degree ¼ NPT X ⅜-inch Tube (includes ferrule and end nut)
*	826-1720	Vent Tube, Teflon 3/8-inch O.D. X 2-foot
3	806-9828	Flexline, with Male/Female Ends
4	810-0278	Valve, Gemini without Handle
5	810-1507	Manifold, H414/17 PS Oil Return
*	810-1505	Manifold, H214/17 PS Oil Return
*	810-1506	Manifold, H314/17 PS Oil Return
6	813-0469	Cap, Pipe ½-inch
7	806-4527SP	<b>Power Shower Assembly, Dual Vat, Complete</b>
8	806-4505SP	<b>Power Shower Assembly, Full Vat, Complete</b>
9	809-0415	Screw, Cleanout
10	814-0001	Grip, Handle
11	816-0026	Seal (Gasket) (2 required)

\* Not illustrated.

### 2.12.3 Rear Flush Oil Return Linkage Assemblies and Components

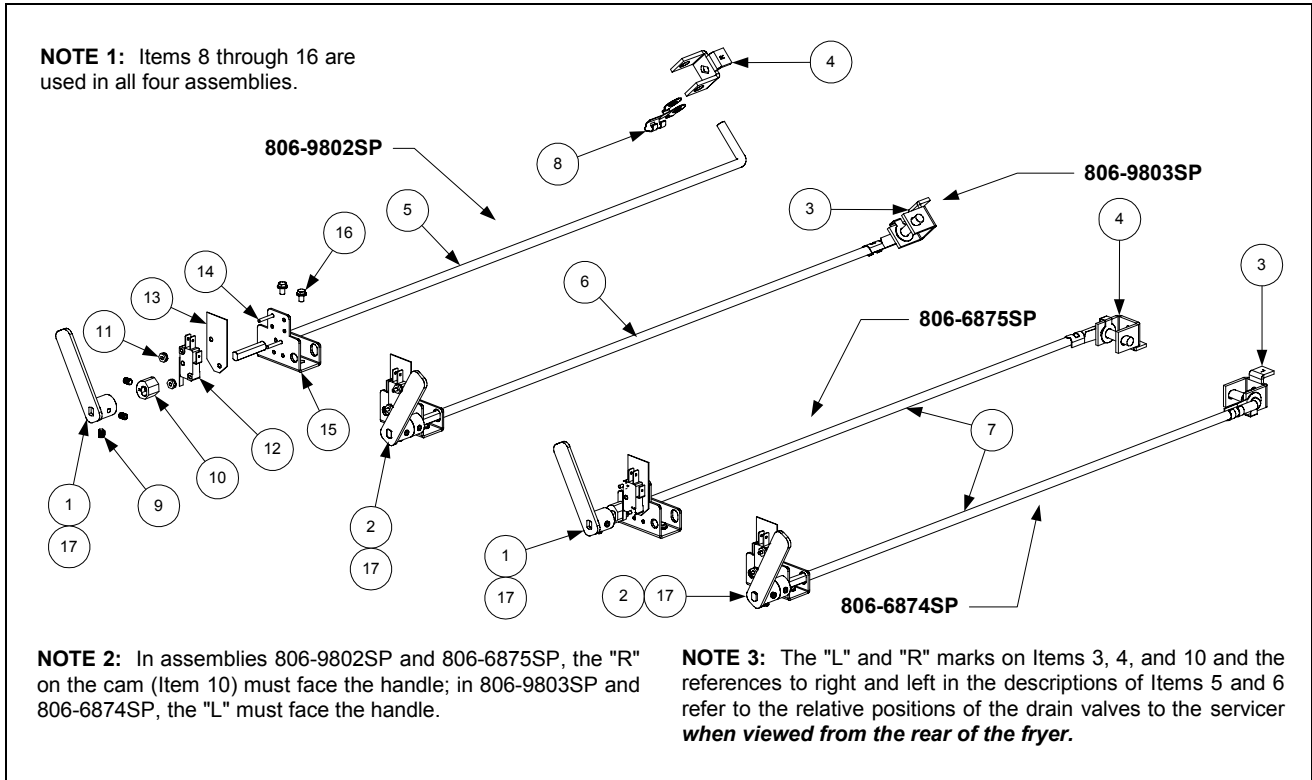

ITEM	PART #	COMPONENT
	806-9802SP	FootPrint III Dual Vat Left Oil Return Linkage Assembly
	806-9803SP	FootPrint III Dual Vat Right or Full Vat Oil Return Linkage Assembly
	806-6875SP	Filter Magic Dual Vat Left Oil Return Linkage Assembly
	806-6874SP	Filter Magic Dual Vat Right or Full Vat Oil Return Linkage Assembly
1	823-2337	Handle, Oil Return, Left
2	823-2338	Handle, Oil Return, Right
3	901-2772	Handle, Rear Flush Valve, Left
4	902-2772	Handle, Rear Flush Valve, Right
5	810-1764	Rod, FootPrint III Oil Return, Right
6	810-1765	Rod, FootPrint III Oil Return, Left
7	810-1180	Shaft, Filter Magic Oil Return
8	809-0601	Clip, <sup>5</sup> / <sub>16</sub> -inch Clevis
9	826-1377	Screw, Set 10-32 x 1/4 (Pkg. of 25)
10	810-1186	Cam, Microswitch
11	826-1366	Nut, 4-40 Hex with External Tooth (Pkg. of 25)
12	807-2103	Microswitch
13	816-0220	Insulation, Microswitch/Bracket
14	826-1359	Screw, 4-40 x 3/4-inch Round Head (Pkg. of 25)
15	900-2571	Bracket, Microswitch
16	809-0359	Screw, #8 x 1/4-inch Slotted Hex Washer Head
17	816-0047	Sleeve, Red Plastic Valve Handle

## 2.13 Frypots and Drain Valve Assemblies

### Drain Valve Assemblies for Units with Built-in Filtration

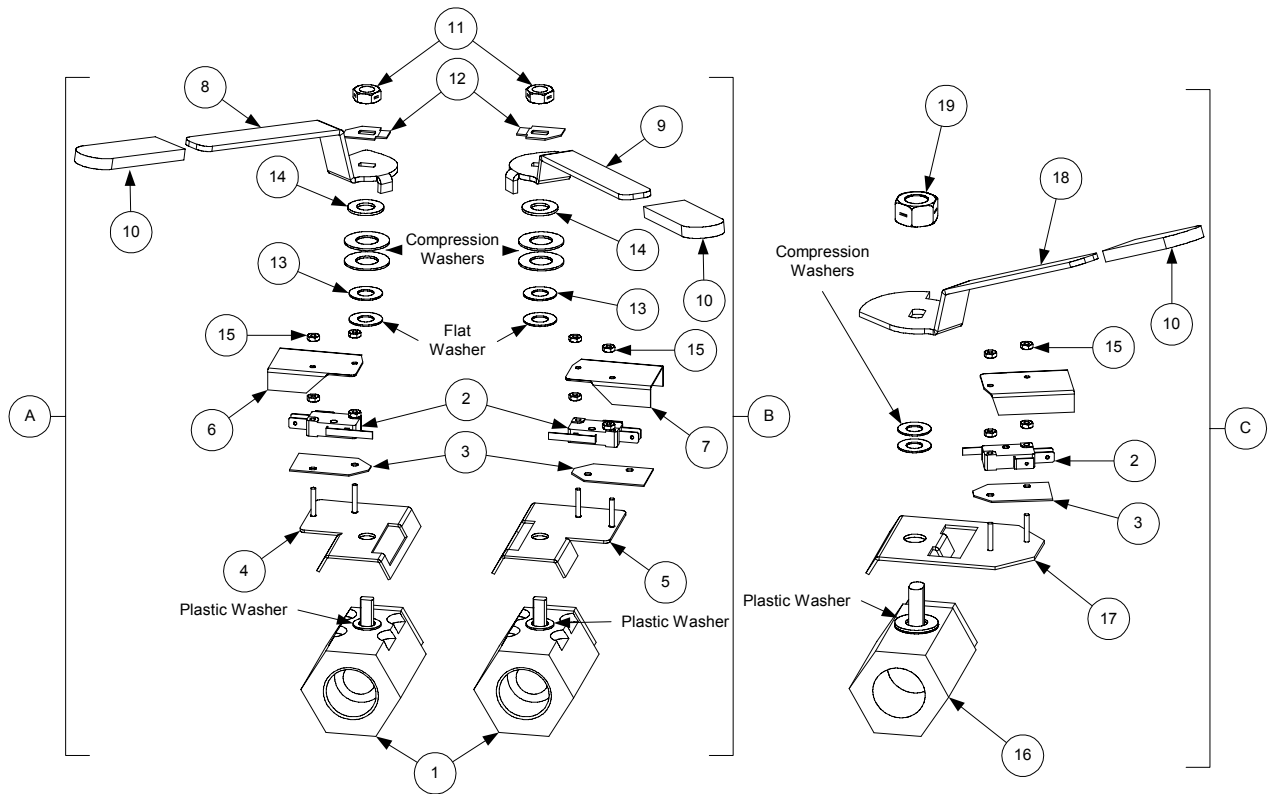

### Drain Valve Assemblies for Units without Built-in Filtration

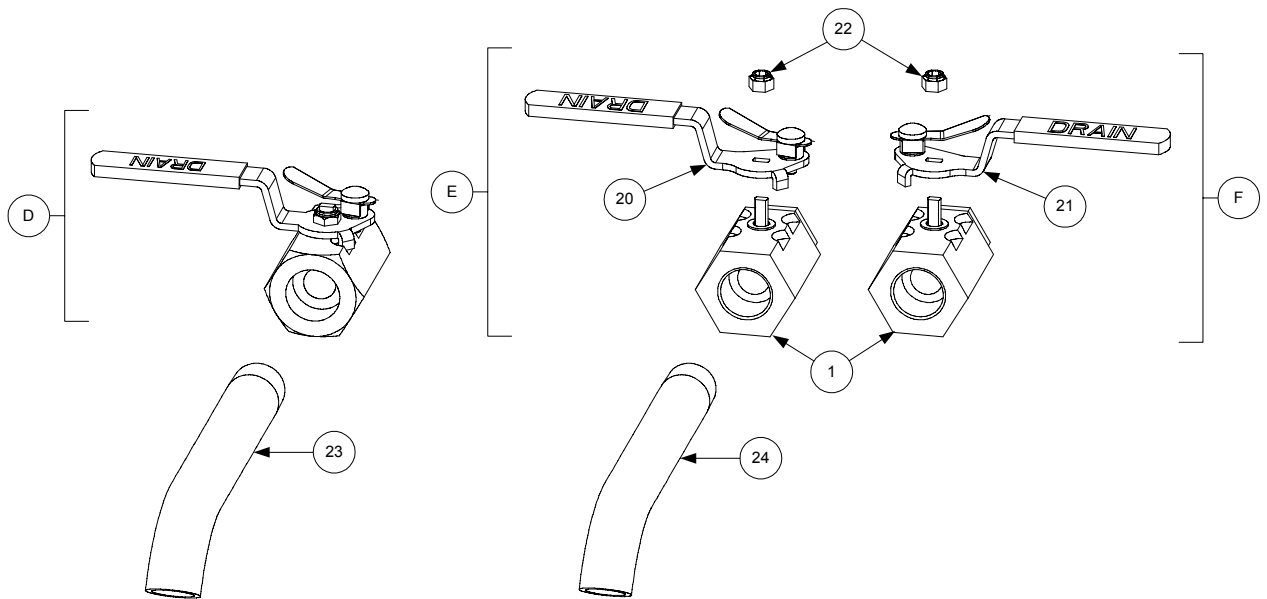

ITEM	PART #	COMPONENT
*		Frypot Assemblies
	823-2450SP	Full-Vat Non-Filter without Insulation
	823-2451SP	Full-Vat Filter without Insulation
	823-2458SP	Dual-Vat Non-Filter without Insulation
	823-2459SP	Dual-Vat Filter without Insulation
	823-0815SP	Dual-Vat Filter without Insulation (for use in single fryers)
	806-8167SP	Full-Vat Non-Filter with Insulation (for use on Triac units)
	806-8168SP	Full-Vat Filter with Insulation (for use on Triac units)
	806-8170SP	Dual-Vat Non-Filter with Insulation (for use on Triac units)
	806-8171SP	Dual-Vat Filter with Insulation (for use on Triac units)
	806-4951SP	Dual-Vat Filter with Insulation (for use in single Triac units)
A	806-7433SP	Valve Assembly, Dual-Vat Left Drain
B	806-7432SP	Valve Assembly, Dual-Vat Right Drain
C	806-7434SP	Valve Assembly, Full-Vat
D	810-1569	Valve Assembly, Full-Vat Non-Filter Drain
E	806-7915SP	Valve Assembly, Dual-Vat Non-Filter Left Drain
F	806-7916SP	Valve Assembly, Dual-Vat Non-Filter Right Drain
1	810-1338	Valve, 1-inch Drain
2	807-2103	Switch, Drain Safety
3	816-0220	Insulation, Drain Safety Switch
4	106-2671	Bracket Assembly, Dual-Vat Left Drain Safety Switch
5	106-2672	Bracket Assembly, Dual-Vat Right Drain Safety Switch
6	901-2348	Cover, Dual-Vat Left Drain Safety Switch
7	902-2348	Cover, Dual-Vat Right Drain Safety Switch
8	201-3916	Handle, Dual-Vat Left Drain Valve
9	200-4304	Handle, Dual-Vat Right Drain Valve
10	814-0047	Sleeve, Red Valve Handle
11	809-0539	Nut, 3/8-16 2-Way Lock
12	900-2934	Retainer, Dual-Vat Drain Valve Nut
13	809-0196	Washer, 3/8-inch Flat
14	810-1165	Washer, Teflon Drain Valve
15	826-1366	Nut, 4-40 Keps Hex (Pkg. of 25)
16	810-1020	Valve, 1 1/4-inch Inlet X 1-inch Outlet
17	806-8137	Bracket Assembly, Full-Vat Drain Safety Switch
18	900-2609	Handle, Full-Vat Drain Valve
19	809-0540	Nut, 1/2-13 2-Way Lock Hex
20	810-1568	Handle, Dual-Vat Left Drain Valve w/Lock Pin
21	810-1567	Handle, Dual-Vat Right Drain Valve w/Lock Pin
22	809-0589	Nut, 1/2-13 2-Way Lock Hex
23	812-1226SP	Extension, Full-Vat Drain Valve (1 1/4-inch)
24	812-1227	Extension, Dual-Vat Drain Valve (1-inch)

\* Not illustrated.

## 2.14 High-Limit Thermostat and Related Components

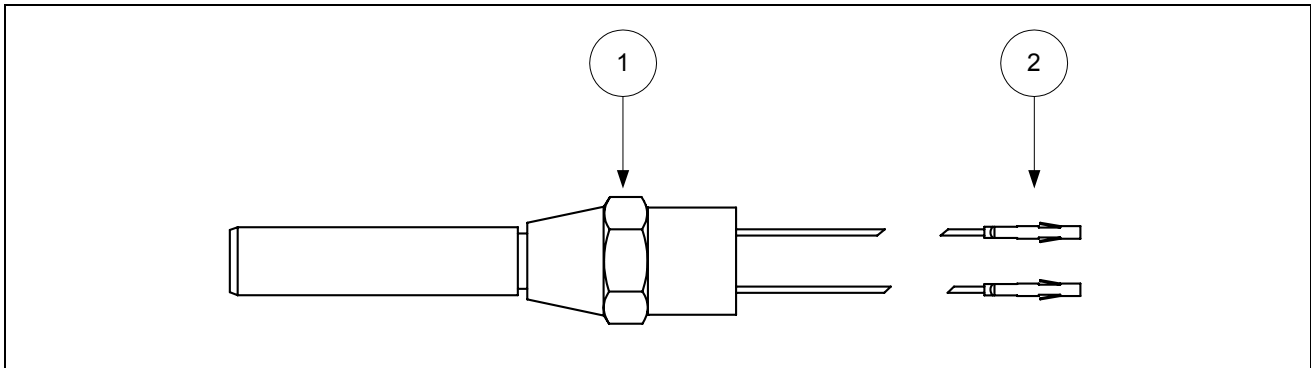

ITEM	PART #	COMPONENT
1		High-Limit Thermostat
	806-7543	Non-CE Full-vat (Color-Coded Black)
	806-8035	Non-CE Dual-vat (Color-Coded Red)
	806-8132	CE other than 22kW (Color-Coded Yellow)
	806-8536	CE 22kW
2	826-1332	Terminal, Female Disconnect Pin (Pkg. of 25)

\* Not illustrated.