

**SERVICE MANUAL
FRYMASTER BIRE14/MRE14 SERIES
ELECTRIC FRYER**



This equipment chapter is to be installed in the Fryer Section of the *Equipment Manual*.

FOR YOUR SAFETY
Do Not Store or use gasoline or other flammable vapors and liquids in the vicinity of this or any other appliance.

**MANUFACTURED
BY**



Enodis
One Company. Countless Solutions

**P.O. BOX 51000
SHREVEPORT, LOUISIANA 71135-1000
PHONE: 1-318-865-1711
TOLL FREE: 1-800-551-8633
1-800-24 FRYER
FAX: 1-318-688-2200**



Frymaster L.L.C., 8700 Line Avenue 71106
P.O. Box 51000, Shreveport, Louisiana 71135-1000
PHONE 318-865-1711 FAX 318-219-7135

PRINTED IN THE UNITED STATES

**SERVICE HOTLINE
1-800-24-FRYER**

APRIL 2006

www.frymaster.com

email: service@frymaster.com

*** 8196152 ***

BIRE14/MRE14 SERIES ELECTRIC FRYERS CHAPTER 2: PARTS LIST

2.1 Accessories

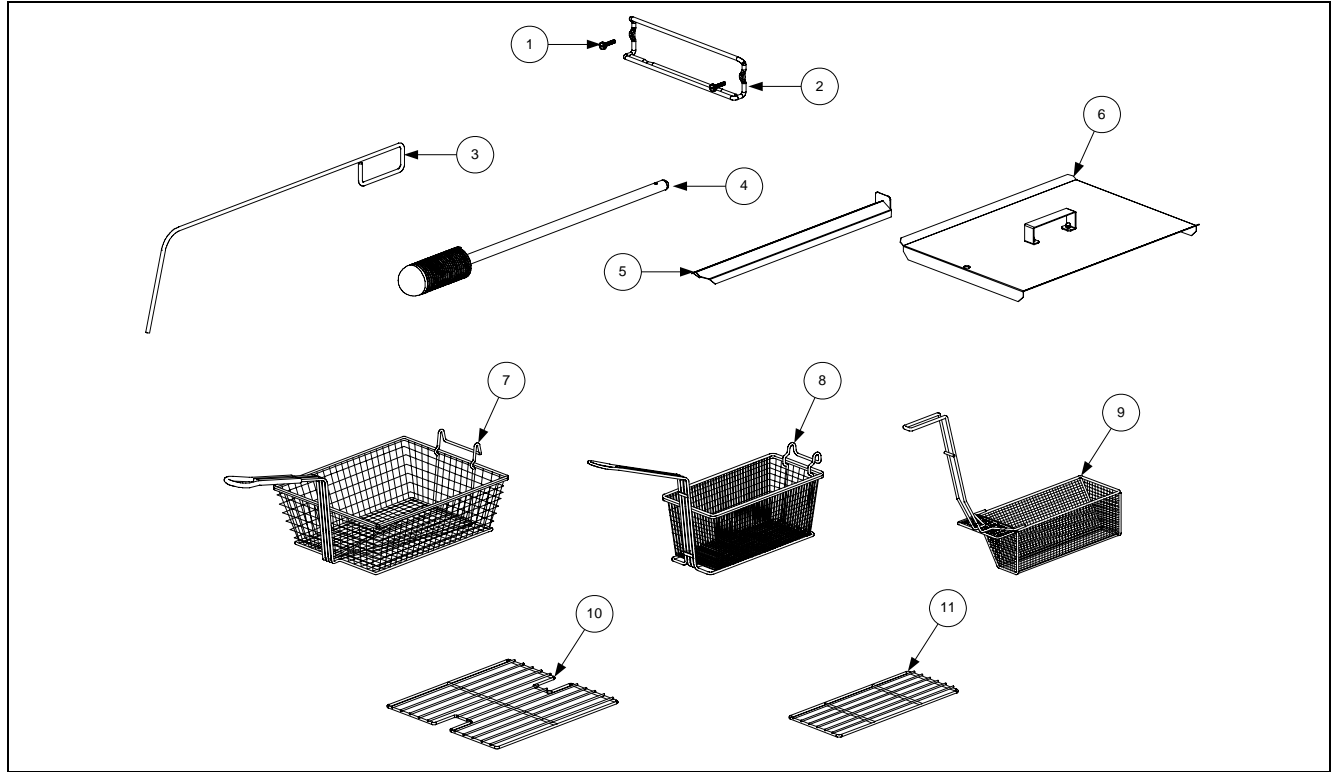

ITEM	PART #	COMPONENT
1	809-0171	Thumbscrew, ¼ -20 X 1⅜-inch
2	810-2793	Hanger, Wireform Basket
*	809-0921	Spacer, Basket Hanger
3	803-0197	Cleanout Rod, 27-inch
4	803-0209	Brush, Frypot
5	823-5772	Connecting Strip, Frypot
6	806-3068	Cover, Full-Vat Frypot
*	806-3071	Cover, Dual-Vat Frypot
7	803-0099	Basket, Full-Vat
8	803-0271	Basket, Dual-Vat (Twin)
9	803-0122	Sediment Tray, Left Dual-Vat
*	803-0123	Sediment Tray, Right Dual-Vat
*	803-0113	Sediment Tray, Full-Vat
10	803-0132	Rack, Full-Vat Basket Support
11	803-0106	Rack, Dual-Vat Basket Support
*	803-0002	Powder, Filter (80- 1-Cup Applications)
*	803-0046	Cup, Plastic Measuring
*	803-0170	Pack, 100-Sheet Filter Paper

*Not illustrated.

2.2 Cabinetry

2.2.1 Back Panels, Control Panel Frames, Doors, Sides, Tilt Housings, and Top Caps

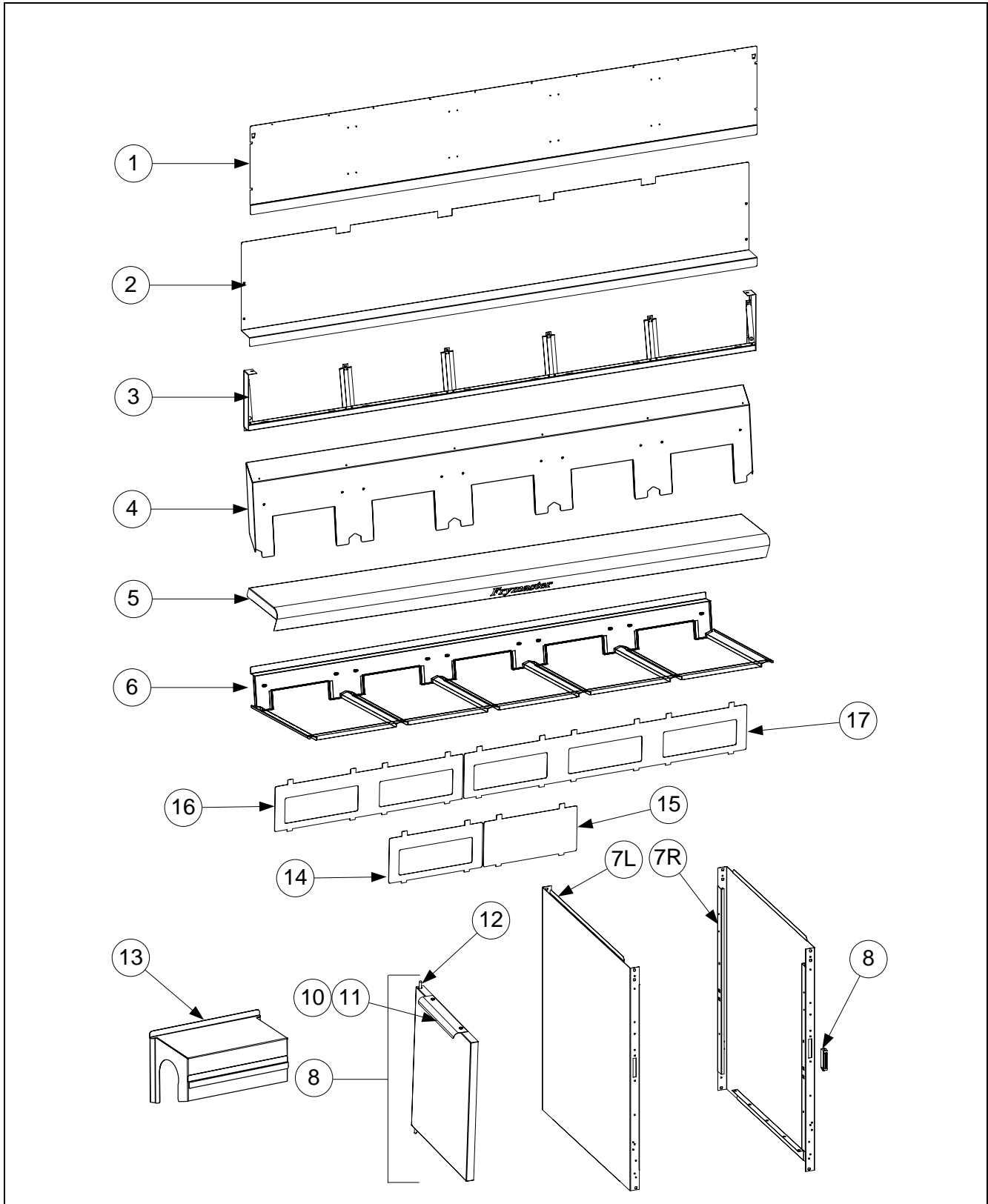

2.2.1 Back Panels, Control Panel Frames, Doors, Sides, Tilt Housings, and Top Caps

ITEM	PART #	COMPONENT
1		Back Panel, Upper (Panel for five station fryer shown)
	220-0421	Single Station Fryer
	220-0419	Two Station Fryer
	220-0423	Three Station Fryer
	220-0425	Four Station Fryer
2	220-0611	Five Station Fryer
		Back Panel, Center (Panel for five station fryer shown)
	220-0501	Single Station Fryer
	220-0487	Two Station Fryer
	220-0491	Three Station Fryer
3	220-0499	Four Station Fryer
	220-0616	Five Station Fryer
		Frame, Control Panel (Frame for five station fryer shown)
	106-5016	Single Station Fryer
	106-5221	Two Station Fryer
4	106-5018	Three Station Fryer
	106-5019	Four Station Fryer
	106-5020	Five Station Fryer
		Tilt Housing (Housing for five station fryer shown)
	823-5402	Single Station, S/S (<i>use 823-5564 for Aluminized Steel</i>)
5	823-5360	Two Station, S/S (<i>use 823-5570 for Aluminized Steel</i>)
	823-5492	Three Station, S/S (<i>use 823-5573 for Aluminized Steel</i>)
	823-5576	Four Station, S/S (<i>use 823-5577 for Aluminized Steel</i>)
	823-5578	Five Station, S/S (<i>use 823-5579 for Aluminized Steel</i>)
		Top Cap (Top cap for five station fryer shown)
*	106-5195	Single Station (<i>Also requires four 809-0078 10-32 Nutserts</i>)
	106-5196	Two Station (<i>Also requires four 809-0078 10-32 Nutserts</i>)
	106-5197	Three Station (<i>Also requires six 809-0078 10-32 Nutserts</i>)
	106-5198	Four Station (<i>Also requires eight 809-0078 10-32 Nutserts</i>)
	106-5199	Five Station (<i>Also requires ten 809-0078 10-32 Nutserts</i>)
*	200-9614	Heat Shield Single Station
	200-9610	Two Station (<i>Two are used on Four Station</i>) (<i>One used on Five station</i>)
	200-9611	Three Station (<i>One used on Five Station</i>)
6		Cap-N-Splash
	823-5715	Single Station
	823-5708	Two Station
	823-5706	Three Station
	823-5710	Four Station
7L	823-5713	Five Station
	231-0323	Side, Standard Cabinet Left SS (use 221-0323 for Enameled Steel)
	232-0323	Side, Standard Cabinet Right SS (use 222-0323 for Enameled Steel)
	810-1105	Magnet, Door
	106-4397	Door, Left or Right (Left shown – move handle to bottom for right)
	809-0266	Screw, #10 X ½-inch Phillips Truss Head
	210-9739	Handle, Eurolook Door
	106-4067	Pin Assembly, Door
	810-0275	Spring, Door Pin
	809-0970	Retaining Ring
	823-5440	Cove, Element Tilt Housing
	210-5046	Bezel, One-Controller
	210-5623	Bezel, Blank
	210-5819	Bezel, Two-Controller
	210-6698	Bezel, Three-Controller

* Not illustrated.

2.2.2 Cabinets, Bases, Braces, and Associated Parts

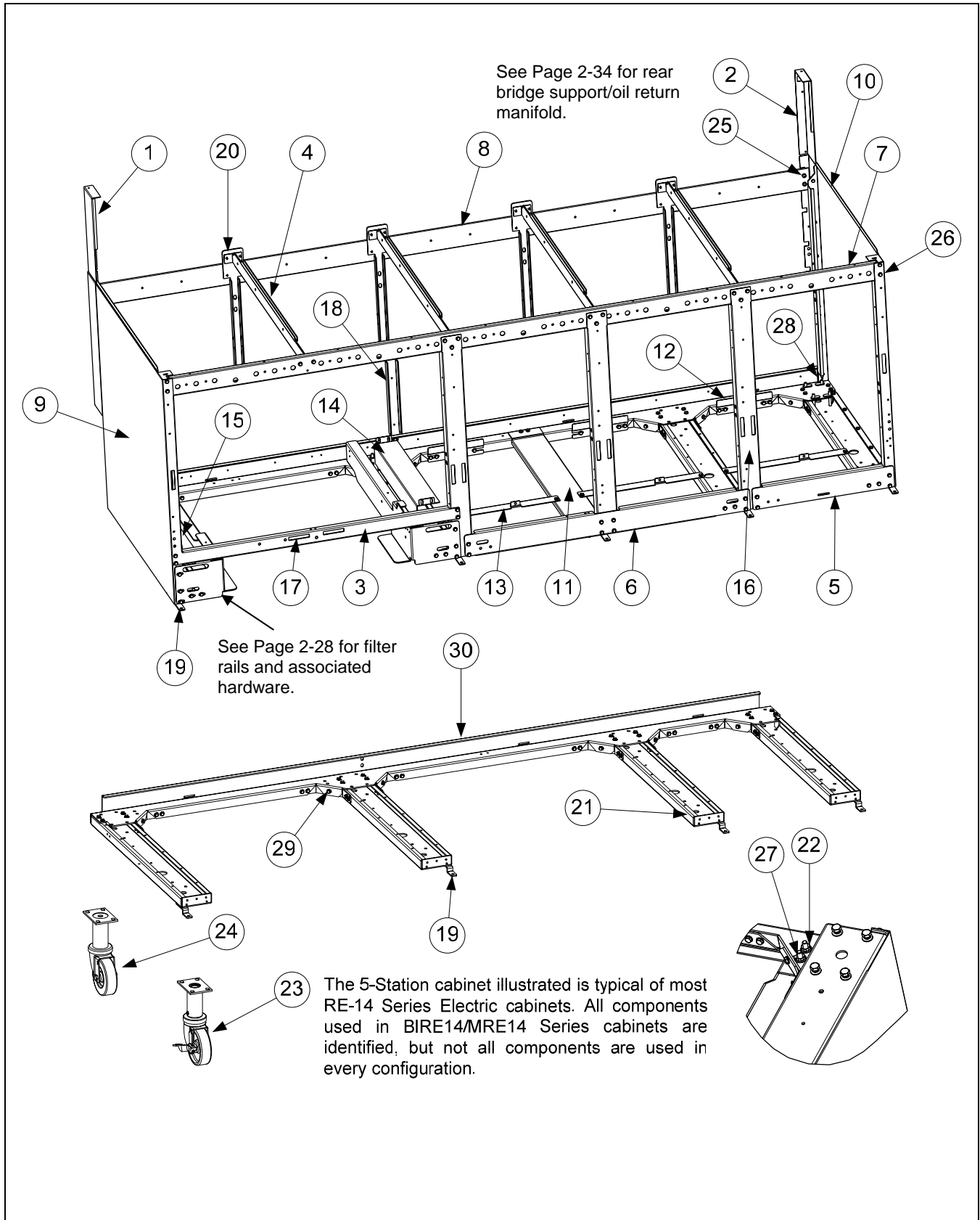

2.2.2 Cabinets, Bases, Braces, and Associated Parts cont.

ITEM	PART #	COMPONENT
1	106-3828	Upright Assembly, Left
2	106-3829	Upright Assembly, Right
3	200-1651	Support, Cross Cabinet
4	200-1659	Divider, Cabinet
5	200-2293	Brace, Single Station Lower
6	200-3774	Brace, Double Station Lower
7		Brace, Front Horizontal
	200-7036	Single-Station Fryer (<i>use 220-0624 for Single-Station Lower Brace</i>)
	200-7037	Two-Station Fryer
	200-7038	Three-Station Fryer
	200-7039	Four-Station Fryer
	200-7040	Five-Station Fryer
8		Brace, Rear Horizontal
	200-5356	Single-Station Fryer
	200-2284	Two-Station Fryer
	200-2295	Three-Station Fryer
	200-2725	Four-Station Fryer
	200-3592	Five-Station Fryer
9	231-0323	Side, Cabinet LH S/S (<i>use 221-0323 for CRS</i>)
10	232-0323	Side, Cabinet RH S/S (<i>use 222-0323 for CRS</i>)
11	220-1100	Support, RE Bottom Contactor Box
12	220-1095	Support, RE Rear Contactor Box
13	220-1093	Brace, RE Front Contactor Box
*	220-1294	Brace, Contactor Box Single-Station Fryer Front
14	222-0610	Bracket, RH Contactor Box Mount
15	221-0610	Bracket, LH Contactor Box Mount
*	200-6498	Bridge, Contactor Box Single-Station Fryer
16	200-4424	Post, Door
17	810-2346	Magnet, Door
18	200-4786	Support, Oil Return Manifold
19	210-6862	Hinge, Door
20	824-1393	Bracket, Rear Support
21	824-4557	Channel, Base Side
*	222-0621	Channel, Base Right Side Single-Station Fryer
*	221-0621	Channel, Base Left Side Single-Station Fryer
22	809-0131	Bolt, 1/4-20 X 3/4-inch Hex Head (<i>also used w/Item 27 to mount filter rails</i>)
23	810-0326	Caster with Brake
24	810-1494	Caster without Brake
25	826-1376	Nut, 10-32 Keps Hex (Pkg. of 10)
26	826-1374	Screw, #10 X 1/2-inch Hex Washer Head (<i>primary cabinet screw</i>)(Pkg. of 25)
27	809-0417	Nut, 1/4-20 Hex Flange
28	809-0429	Bolt, 1/4-20 X 2-inch Hex Head
29	200-5417	Brace, Rear Channel Corner
30		Channel, Base Rear
	823-5589	Single-Station Fryer Base
	823-4558	Two-Station Fryer
	823-4560	Three-Station Fryer
	823-4561	Four-Station Fryer
	823-4562	Five-Station Fryer
*	810-3010	Leg, Single Fryer Single-Station Fryer
*	824-1705	Bridge, Pump/Motor Single-Station Fryer
*	809-0495	Nut, 1/4" - 20 Press

* Not illustrated.

2.3 Drain System Components

2.3.1 Drain Tube Sections and Associated Parts

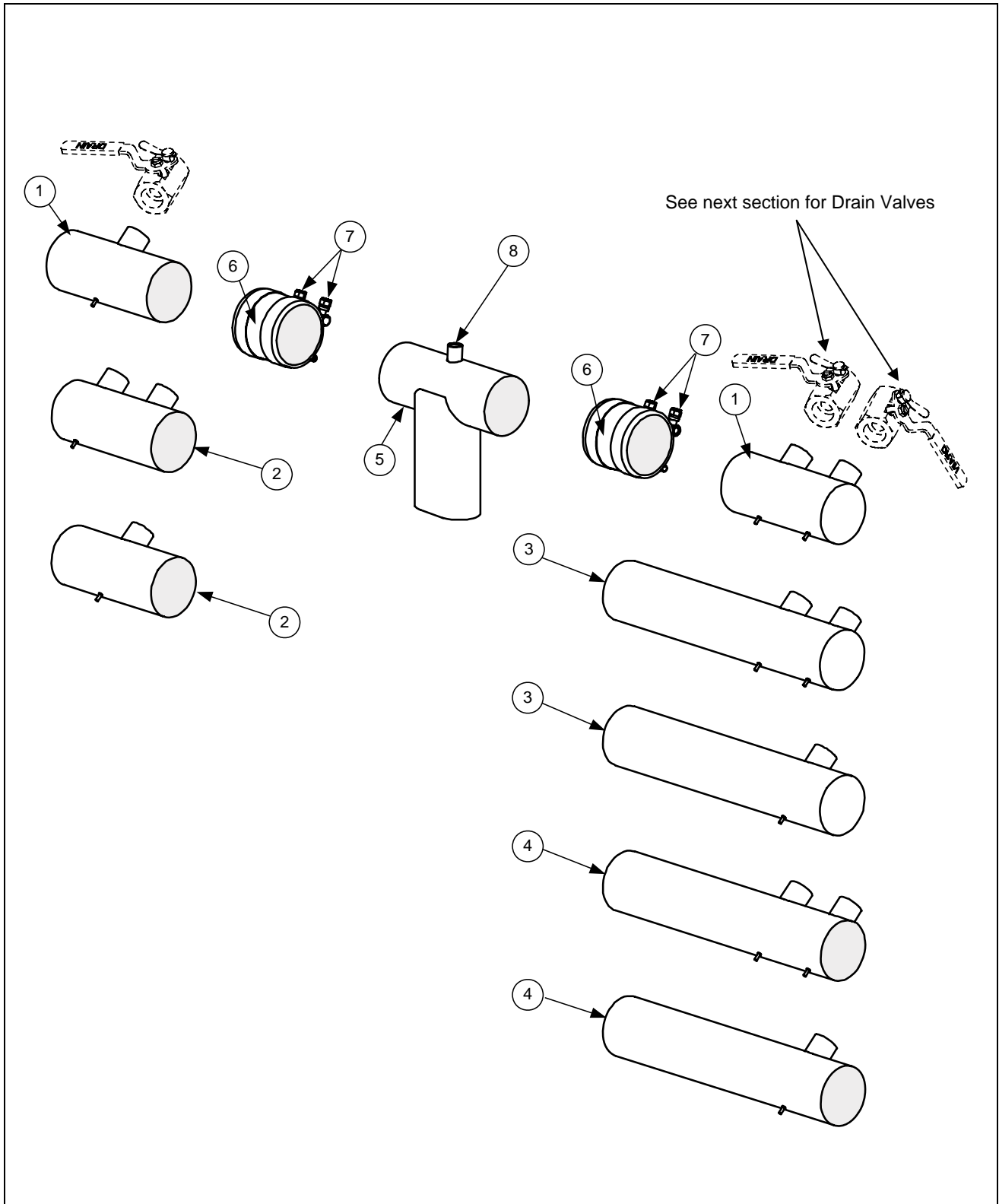

2.3.1 Drain Tube Sections and Associated Parts cont.

ITEM	PART#	COMPONENT
1		Drain Tube, Left/Right End Short
	823-4625	Full-Vat
	823-4624	Dual-Vat
2		Drain Tube, Left/Right Open Short
	823-4643	Full-Vat
	823-4642	Dual-Vat
3		Drain Tube, Right End Long
	823-4639	Full-Vat
	823-4638	Dual-Vat
4		Drain Tube, Left/Right Open Long
	823-4641	Full-Vat
	823-4640	Dual-Vat
5	823-4892	Drain Outlet
6	816-0625	Sleeve
7	809-0969	Clamp
*	816-0630	Vinyl Cap
8	810-2492	Fitting, Quick-Connect Straight (receives Teflon vent tube)
*	KIT6033	Kit, Round Drain Clamp (contains 2 of Item 7 and 1 of Item 6)
*	811-1071	Tube, Teflon Vent (sold by the foot)

* Not illustrated.

2.3.2 Drain Valves and Associated Parts (Units with Built-In Filtration)

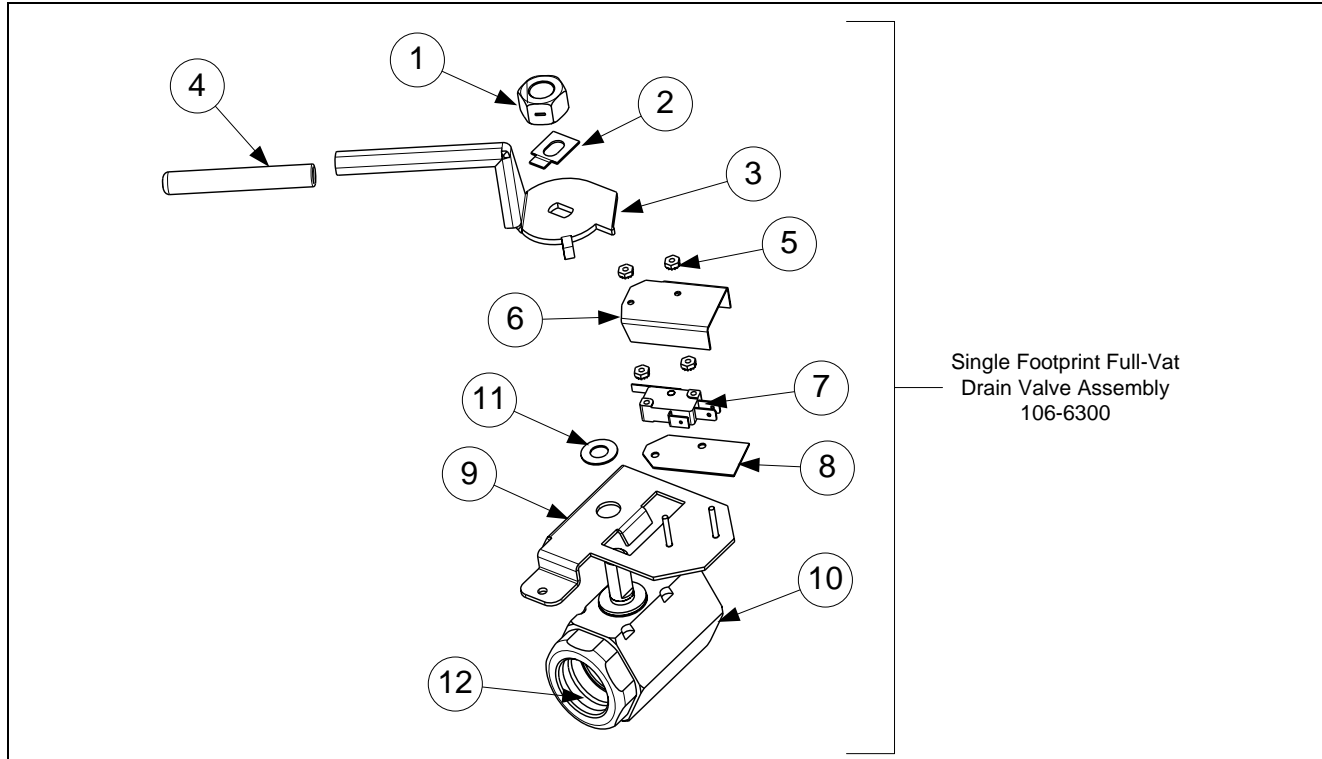

2.3.2 Drain Valves and Associated Parts (Units with Built-In Filtration) cont.

ITEM	PART #	COMPONENT
1	809-0540	Nut, 1/2-13 2-Way Hex Lock
2	900-2936	Retainer, Full-Vat Nut Drain Valve
3	824-1602	Handle, Full-Vat Drain Valve
4	816-0639	Cap, Red Handle
5	809-0237	Nut, 4-40 Keps Hex
6	901-2348	Cover, Dual Vat Drain Safety Switch
7	807-2103	Microswitch, CE Straight Lever
8	816-0220	Insulation, Drain Safety Switch
9	106-5391	Bracket Assembly, Full-Vat Drain Safety Switch Single Footprint Only
10	810-1018	Valve, 1.25-inch Full-Vat Drain Single FP
11	810-1165	Washer, Teflon
12	816-0135	O-Ring

2.3.2 Drain Valves and Associated Parts (Units with Built-In Filtration) cont.

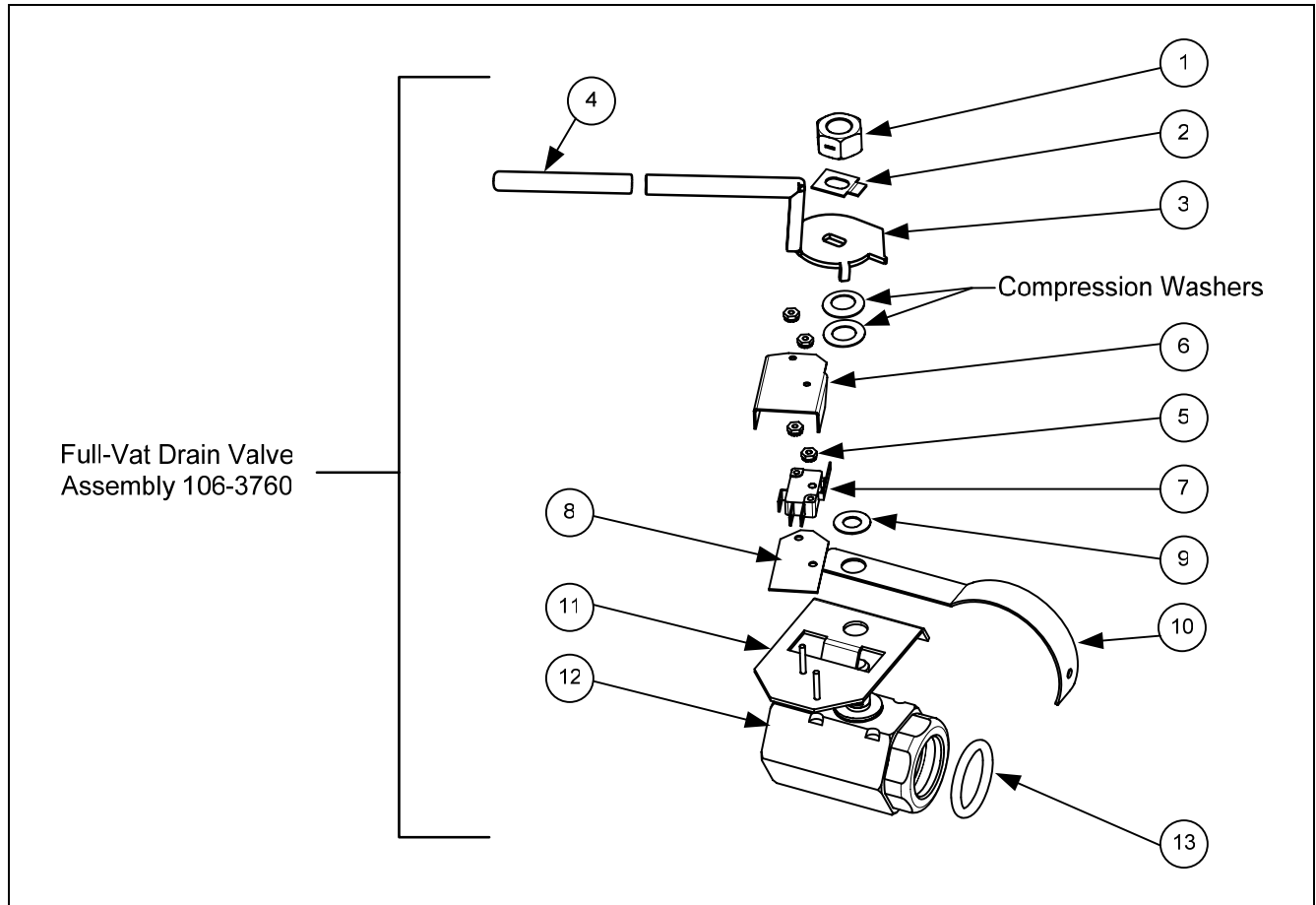

2.3.2 Drain Valves and Associated Parts (Units with Built-In Filtration) cont.

ITEM	PART #	COMPONENT
1	809-0540	Nut, ½-13 2-Way Hex Lock
2	900-2936	Retainer, Full-Vat Drain Valve Nut
3	824-1602	Handle, Full-Vat Drain Valve
4	816-0639	Cap, Red Handle
5	809-0237	Nut, 4-40 Keps Hex
6	901-2348	Cover, Dual Vat Drain Safety Switch
7	807-2103	Microswitch, CE Straight Lever
8	816-0220	Insulation, Drain Safety Switch
9	810-1165	Washer, Teflon Drain Valve
10	200-6496	Support, 3" Drain
11	806-8137	Bracket Assembly, Full-Vat Drain Safety Switch
12	810-1018	Valve, 1.25-inch Full-Vat Drain
13	816-0135	Round Drain O-Ring

2.3.2 Drain Valves and Associated Parts (Units with Built-In Filtration)

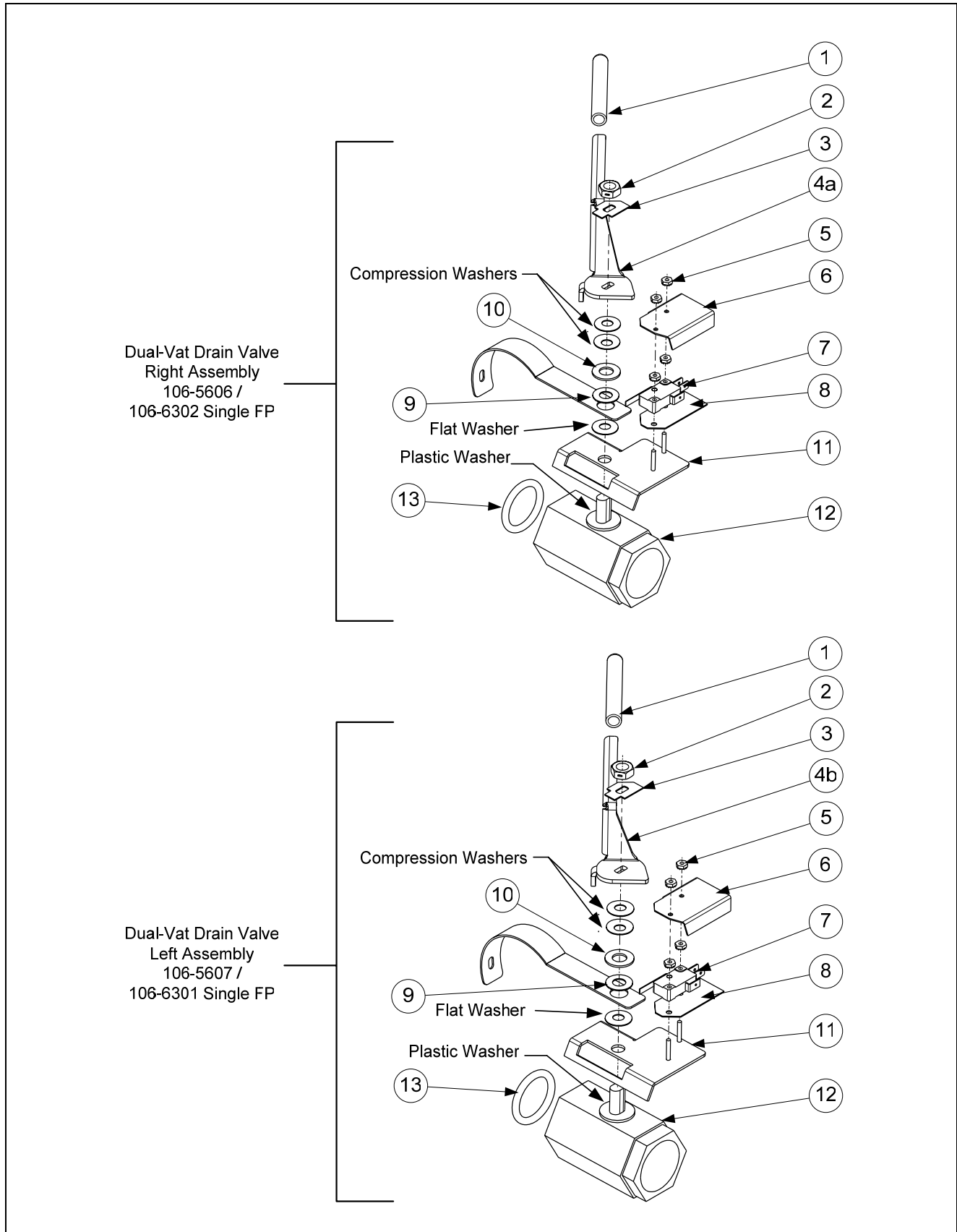

2.3.2 Drain Valves and Associated Parts (Units with Built-In Filtration) cont.

ITEM	PART#	COMPONENT
1	816-0639	Cap, Drain Handle
2	809-0539	Nut, 3/8-16 2-Way Hex Lock
3	900-2934	Retainer, Dual-Vat Drain Valve Nut
4a	824-1636	Handle, Dual-Vat Right Drain Valve
4b	824-1637	Handle, Dual-Vat Left Drain Valve
5	809-0237	Nut, 4-40 Keps Hex
6	901-2348	Cover, Dual Vat Drain Safety Switch
7	807-2103	Microswitch, CE Straight Lever
8	816-0220	Insulation, Drain Safety Switch
9	810-1165	Washer, Teflon Drain Valve
10	809-0196	Washer, 3/8-inch Flat
11	106-2671	Bracket Assembly, Dual-Vat Drain Safety Switch
	106-6304	Bracket Assembly, Dual-Vat Drain Safety Switch Single Footprint Only
12	810-1114	Valve, 1-inch Dual-Vat Drain
13	816-0135	Round Drain O-Ring
*	823-5592	Tube, Drain Single-Station Only with Filter

*Not illustrated.

2.3.3 Drain Valves and Associated Parts (Units without Built-In Filtration)

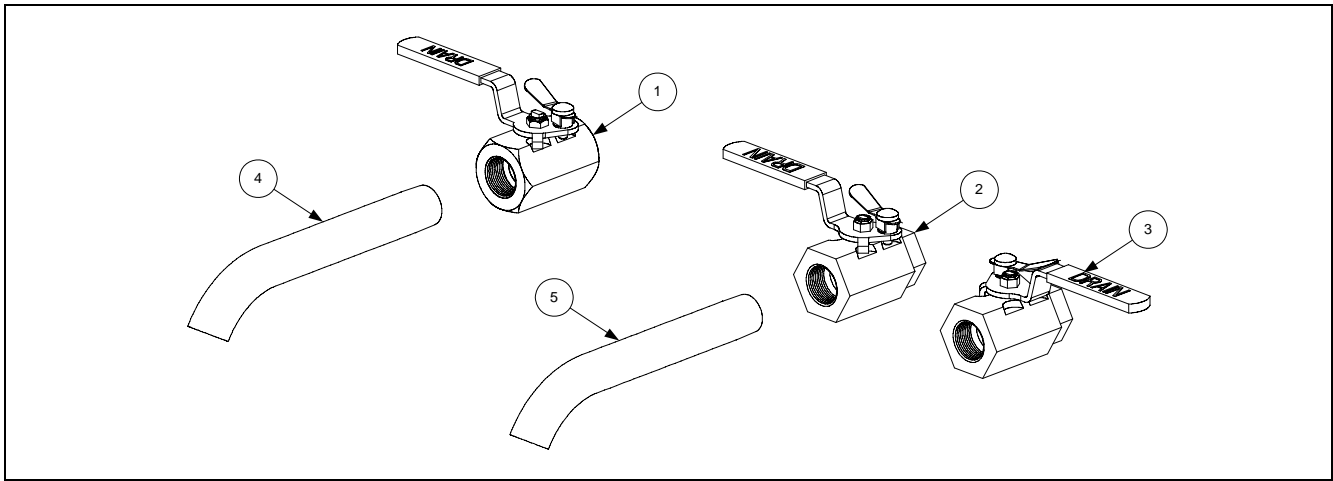

ITEM	PART #	COMPONENT
1	810-1569	Valve, 1.25-inch Non-Filter Full-Vat Drain
2	806-7915SP	Valve, 1-inch Non-Filter Dual-Vat Left Drain
3	806-7916SP	Valve, 1-inch Non-Filter Dual-Vat Right Drain
4	812-1226	Drain Extension, 1.25-inch
5	812-1227	Drain Extension, 1-inch

2.4 Electronics and Wiring Components

2.4.1 Component Boxes

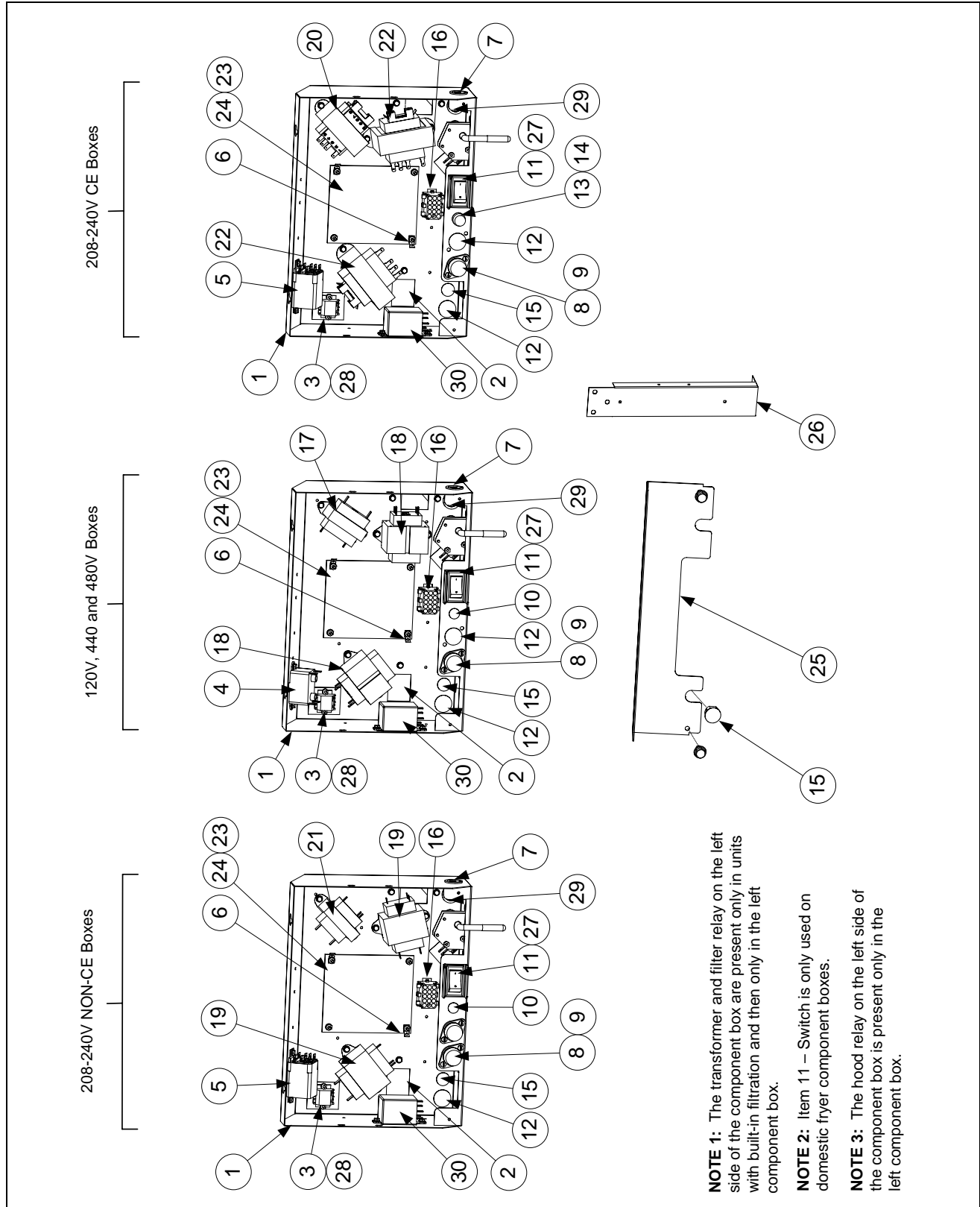

2.4.1 Component Boxes cont.

ITEM	PART #	COMPONENT
1	106-5592	Box Assembly, Component
2	200-3300	Bracket, Component Box Strain Relief
3	806-9495SP	Terminal Block
4	807-0012	Relay, Filter 18 Amp 1/3 HP 24V
5	807-0670	Relay, Filter Mintex DPDT 24V
6	807-0037	Terminal, 1/4-inch Push-on
7	807-0121	Bushing, Heyco Plastic AB-625-500
8	807-0922	Holder, Buss Fuse HPS
9	807-2278	Fuse, 20 Amp
10	810-2446	Plug, Button .50 Heyco Double "D"
11	807-4036	Switch
	807-3575	Plug, Carling Switch Hole (<i>used on some models without a switch</i>)
12	807-1947	Plug, Button .875 Dome
13	807-1321	Holder, AGC Panel Mount 1/4" Fuse (<i>Some models use item 10 here.</i>)
14	807-1597	Fuse, 3 AMP Slow-Blow
15	810-2445	Plug, Button .625 Heyco Double "D"
16	106-5750	Harness Assembly, RE FV Control
	106-5751	Harness Assembly, RE DV Control
17	807-0855	Transformer, 100-120V/12V 20VA
18	807-0800	Transformer, 100-120V/24V 50VA Filter
19	807-0680	Transformer, 208-240V/24V 20VA Filter
20	807-2191	Transformer, 208-240V/12V 30VA
21	807-0979	Transformer, 208-240V/12V 43VA
22	807-2180	Transformer, 208-240V 50VA Filter
23	809-0349	Spacer, 4mm X 6mm Aluminum
24		Interface Board (<i>SMT interface boards do not have replaceable relays</i>)
	826-2260	Standard Full or Dual Vat Interface Board (<i>incl. SMT speaker harness</i>)
	826-2257	EPRI, Full- or Dual-Vat (<i>includes SMT speaker harness</i>)
*	807-3932	Relay, Latch/Heat 12VDC SPDT 12A Sealed (<i>SMT interface boards do not have replaceable relays</i>)
25	220-0565	Guard, Finger Domestic and Non-CE
	220-1061	Guard, Finger Non-Domestic and CE
26	200-6654	Brace, Component Box
27	230-0834	Guard, RE Box Switch
28	816-0217	Paper, Insulating Terminal Block
29	810-0045	Bushing, .875 Diameter 11/16"
30	807-2515	Relay, 120V SPDT 10A (<i>used in Canadian models only</i>)
*	826-2249	RE Hood/Ansul Interlock Kit (<i>includes terminal block, wires and connectors</i>)
*	807-3520	Speaker, 4-Watt
*	807-4330	Sound Device Adaptor Harness (SMT)

* Not illustrated.

2.4.2 Contactor Boxes

2.4.2.1 Left and Right Over the Filter Pan Contactor Box Configurations

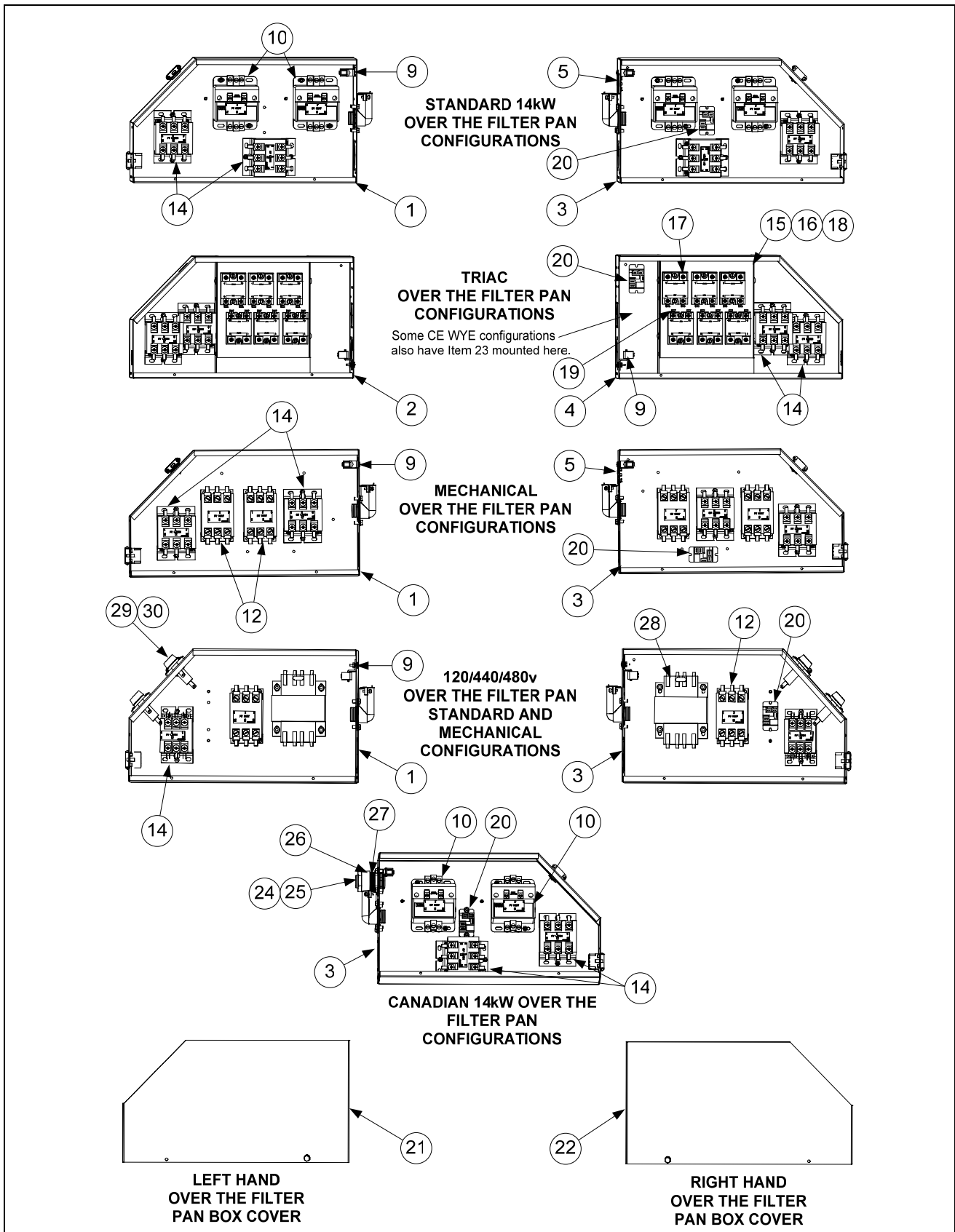

2.4.2.1 Left and Right Over the Filter Pan Contactor Box Configurations

NOTES: Left and right contactor box assemblies are mirror images of one another. With the exception of the box itself, all components of a left-hand assembly are the same as those in the corresponding right-hand assembly and vice versa except for the hood relay which occurs in the right or large box only. The configurations illustrated show all possible components, but a particular configuration may not have all the components shown.

ITEM	PART #	COMPONENT
1	106-5488	Box Assembly, Left Contactor (Over the Filter Pan)
2	823-5736	Box Assembly, Left Contactor EPRI (Over the Filter Pan)
3	106-5489	Box Assembly, Right Contactor (Over the Filter Pan)
4	823-5748	Box Assembly, Right Contactor EPRI (Over the Filter Pan)
5	810-2554	Plug, Cord Cutout 1.125 Button
6	807-1947	Plug, .875 Diameter Dome
7	221-0482	Cover, Left Hand Contactor Box
8	222-0482	Cover, Right Hand Contactor Box
9	807-0070	Terminal, Ground Lug
10	807-1071	Contactor, 24V 30 Amp Mercury
11	807-0884	Contactor, 24V 50 Amp Mercury
12	807-2284	Contactor, 24V 50 Amp Mechanical
13	807-2283	Contactor, 24V 63 Amp Mechanical
14	810-1202	Contactor, 24V 40 Amp Mechanical
15**	806-8674	Heatsink Assembly, DV Solid State Relay (See components below)
16**	806-8673	Heatsink Assembly, FV Solid State Relay (See components below)
		Components of Items 15 and 16
17	826-1562	Kit Relay, Solid State 40 Amp 280V with Heatsink
18	807-2749	Heatsink, Solid State
19	807-0037	Terminal, ¼-inch Push-on
20	807-1683	Relay, Hood 12VDC
21	221-0482	Cover, Left Contactor Box Top (Over the Filter Pan Box)
22	222-0482	Cover, Right Contactor Box Top (Over the Filter Pan Box)
23	106-6204	Filter Assembly, EPRI (<i>used in CE WYE-configured EPRI units only</i>)
24	807-4316	McDonald's Cordset, 120V 5-Wire
25	807-4317	McDonald's Cordset, Europe 3-Wire Single Phase
26	807-1560	Strain Relief
27	220-1102	Plate, MRE Control Cord Relief
28	807-0064	Transformer, 480V/120V 150VA
29	807-0922	Holder, Bus Fuse
30	807-2278	Fuse, 20 Amp
*	221-0610	Bracket, Left Hand Contactor Box Mounting
*	222-0610	Bracket, Right Hand Contactor Box Mounting
*	807-0012	Relay, Tilt Switch 18 Amp 1/3 HP 24 V Coil

* Not illustrated.

** Dual-vat assembly has six relays (826-1562); Full-vat assembly has three relays.

2.4.2.2 Large Center Contactor Box Configurations (Non-Filter, Not Over the Filter and Single Units)

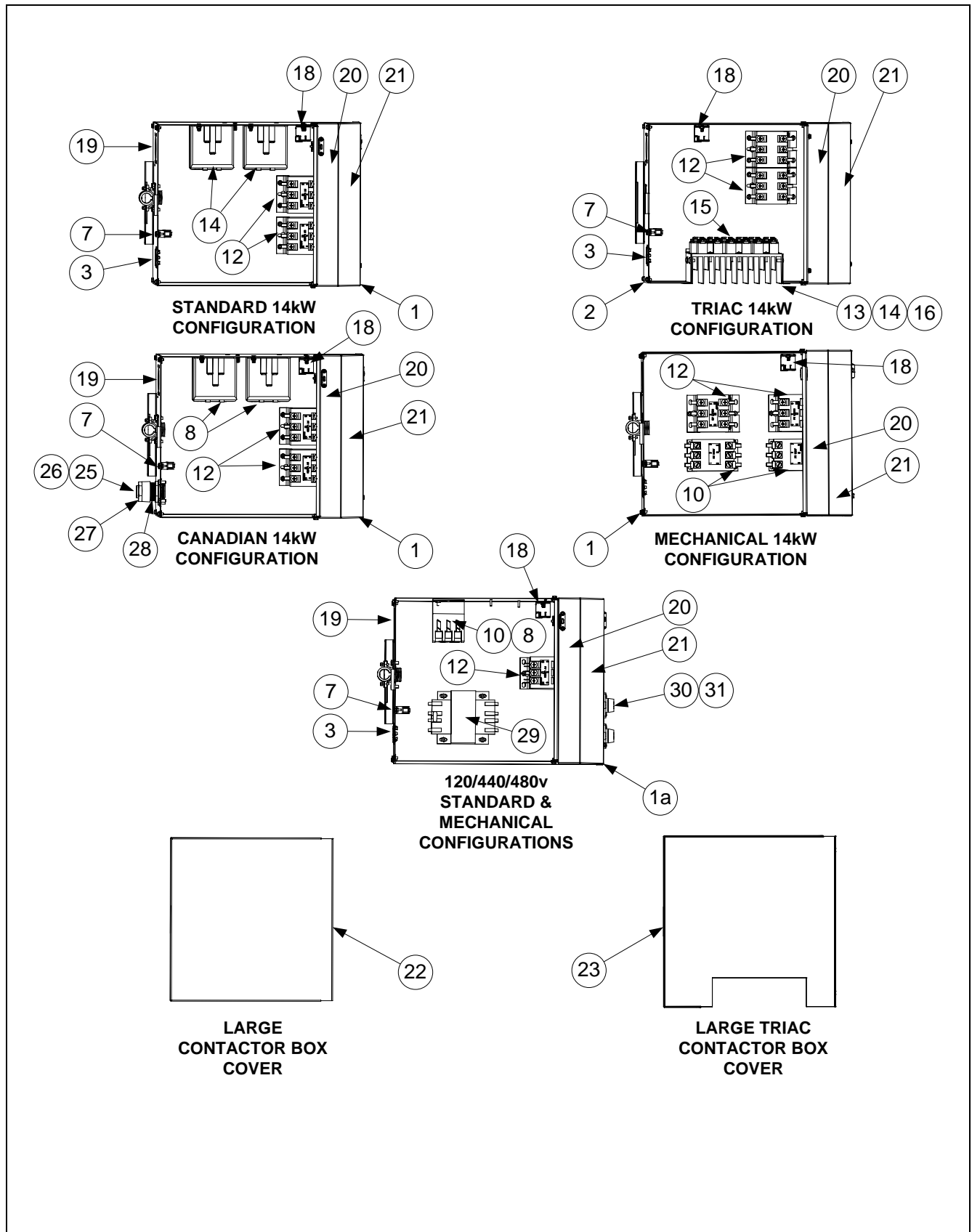

2.4.2.2 Large Center Contactor Box Configurations (Non-Filter, Not over the Filter and Single Units) cont.

ITEM	PART #	COMPONENT
1	106-6081	Box Assembly, Contactor (Non-Filter or Not Over the Filter Pan)
1a	106-6255	Box Assembly, Contactor (Non-Filter or Not Over the Filter Pan) <i>120/440/480V</i>
2	106-6173	Box Assembly, Contactor EPRI (Non-Filter or Not Over the Filter Pan)
*	106-6244	Box Assembly, Contactor Single-Station Fryer Only
3	810-2554	Plug, Cord Cutout 1.125 Button
4	807-1947	Plug, .875 Diameter Dome
5	221-0482	Cover, Left Hand Contactor Box
6	222-0482	Cover, Right Hand Contactor Box
7	807-0070	Terminal, Ground Lug
8	807-1071	Contactor, 24V 30 Amp Mercury
9	807-0884	Contactor, 24V 50 Amp Mercury
10	807-2284	Contactor, 24V 50 Amp Mechanical
11	807-2283	Contactor, 24V 63 Amp Mechanical
12	810-1202	Contactor, 600V 40 Amp 3-Pole
13**	806-8674	Heatsink Assembly, DV Solid State Relay (See components below)
14**	806-8673	Heatsink Assembly, FV Solid State Relay (See components below)
		Components of Items 13 and 14
15	826-1562	Kit Relay, Solid State 40 Amp 280V with Heatsink
16	807-2749	Heatsink, Solid State
17	807-0037	Terminal, ¼-inch Push-on
18	807-1683	Relay, Hood 12VDC
19	823-5729	Plate, Contactor Back Cordset
20	220-1087	Bracket, Box Connecting
21	220-1088	Cover, Contactor Box Front
22	220-1089	Cover, Contactor Box Top (Non-Filter or Not Over the Filter Pan)
*	220-1175	Cover, Contactor Box Top Full Vat Single-Station Fryer Only
*	220-1373	Cover, Contactor Box Top Dual Vat Single-Station Fryer Only
23	220-1152	Cover, Contactor Box Top EPRI (Non-Filter or Not Over the Filter Pan)
24	106-6204	Filter Assembly, EPRI (<i>used in CE WYE-configured EPRI units only</i>)
25	807-4316	McDonald's Cordset, 120V 5-wire
26	807-4317	McDonald's Cordset, Europe 120V 3-wire Single Phase
27	807-1560	Strain Relief
28	220-1102	Plate, Control Cord Relief
29	807-0064	Transformer, 480V/120V 150VA
30	807-0922	Holder, Bus Fuse
31	807-2278	Fuse, 20 Amp
*	807-0012	Relay, Tilt Switch 18 Amp 1/3 HP 24 V Coil

* Not illustrated.

** Dual-vat assembly has six relays (826-1562); full-vat assembly has three relays.

2.4.3 Terminal Blocks

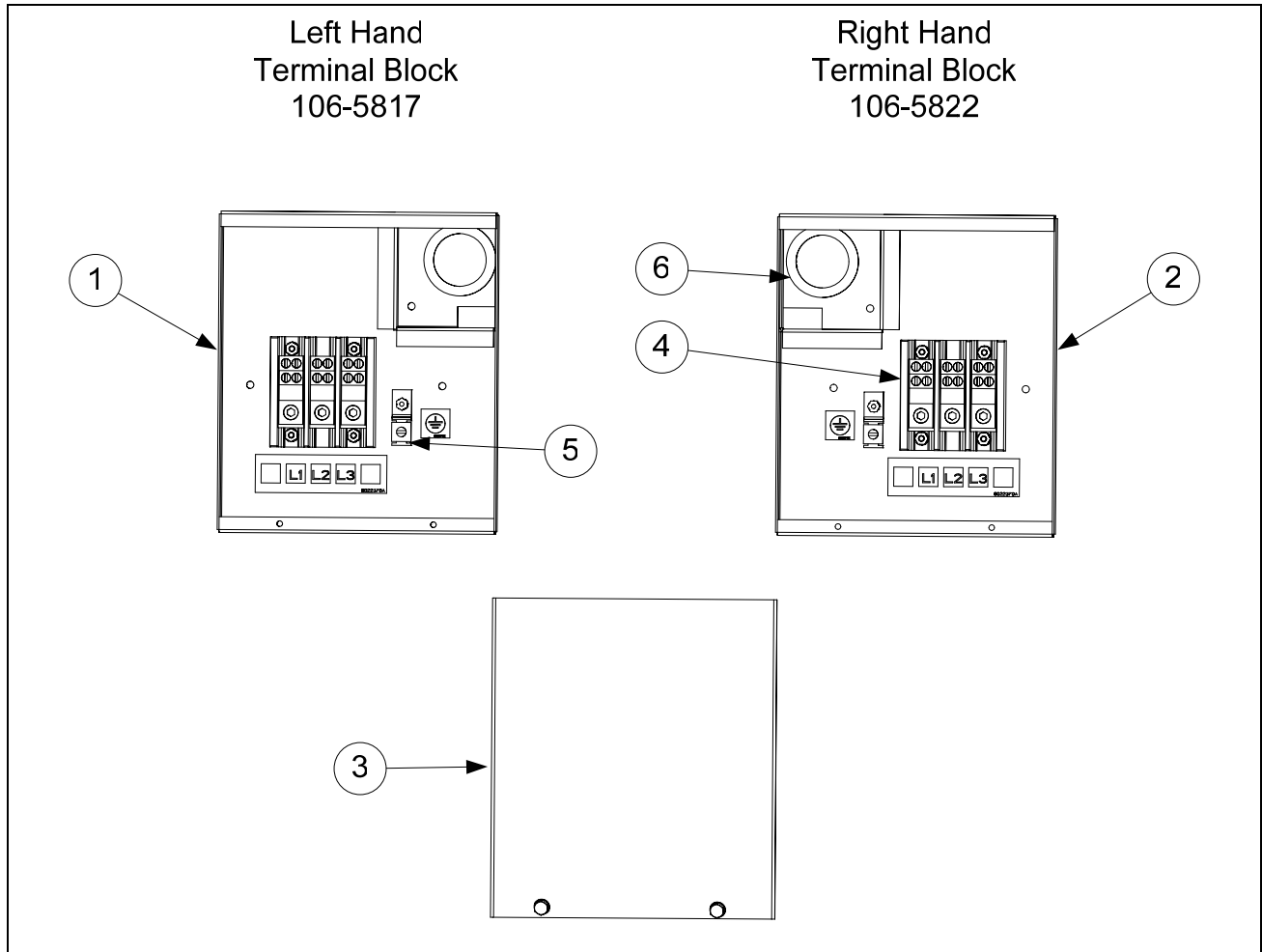

ITEM	PART #	COMPONENT
1	823-5631	Box, LH Rear Terminal Block
2	823-5632	Box, RH Rear Terminal Block
3	220-0801	Cover, Rear Terminal Block Box
4	807-3970	Block, 3 Pole 600V 175A
5	807-0070	Terminal, Ground Lug
6	807-0128	Bushing, Insulating Heyco

2.4.4 Heating Element Assemblies and Associated Parts

2.4.4.1 Element Assemblies and Hardware

FULL-VAT ELEMENT ASSEMBLY

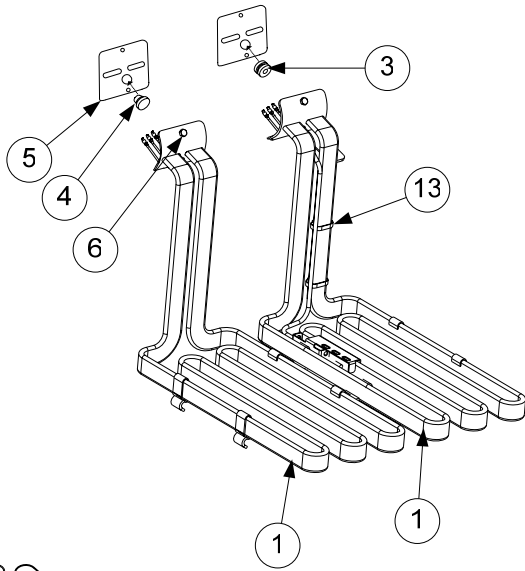

DUAL-VAT ELEMENT ASSEMBLY

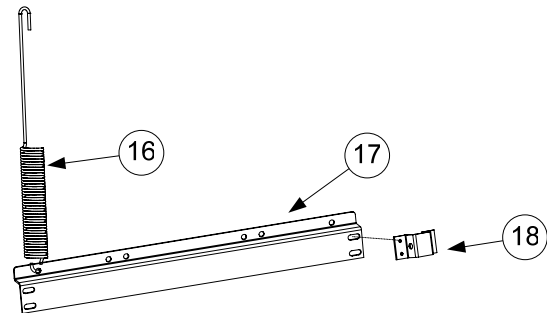
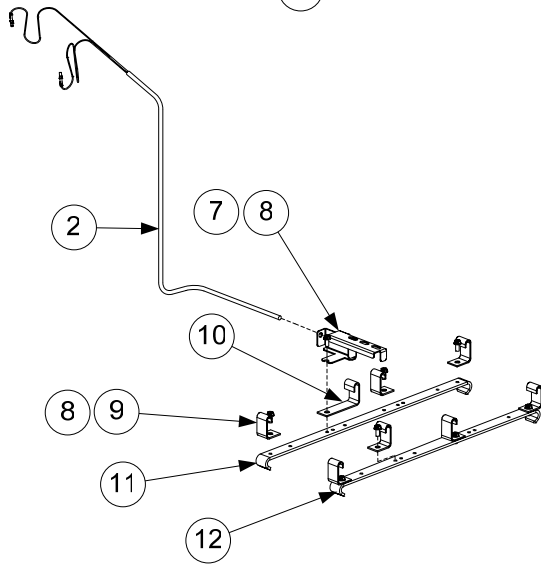
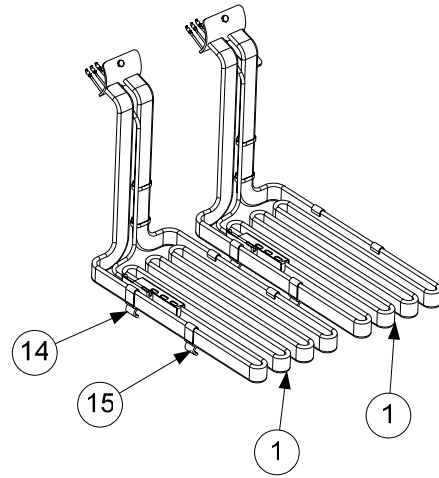

NOTES:

The dual-vat assembly is almost the same as the full-vat assembly except for having two of Items 2 and 7, two of Item 14 in place of Item 11, two of Item 15 in place of Item 12, and two of Item 3 instead of one Item 3 and one Item 4. The only difference between element assemblies for different voltage and kW ratings is the element itself (Item 1).

Items 16,17 and 18 are shown as associated parts. They are not part of either assembly.

NOTE: These elements apply only to RE series fryers. For the previous model elements see manual PN 819-6011.

2.4.4.1 Element Assemblies and Hardware cont.

ITEM	PART #	COMPONENT
1		Element
	826-2198	200V 7.0 kW
	826-2192	208V 7.0 kW
	826-2200	220V 7.0 kW
	826-2193	230V 7.0 kW
	826-2199	230V/400V 7.0/8.5 kW (used in some export 3-phase 4-wire WYE units)
	826-2194	240V 7.0 kW
	826-2196	480V 7.0 kW
2	826-2212	Probe, Temperature RE – includes tie wraps and grommet.
3	816-0681	Grommet, Probe
4	816-0480	Plug, .375-inch Dome
5	816-0688	Gasket, Element
6	809-1003	Screw, 10-32 X 3/8-inch Hex Head SS
*	809-0766	Nut, 10-32 Keps Hex Head SS
7	910-5022	Bracket, Temperature Probe 7.0kW
	230-0784	Bracket, Temperature Probe 8.5kW (used in some export 3-phase 4-wire WYE units)
8	809-0518	Screw, 8-32 X 3/8-inch Slotted Hex Head
9	910-2042	Clamp, Element (Short)
10	230-0781	Clamp, Element (Long)
11	230-0780	Support, Full-Vat Element Rear
12	823-5621	Support, Full-Vat Element Front
13	809-0567	Tie-Wrap, Metal
14	230-0791	Support, Dual-Vat Element Rear
15	823-5624	Support, Dual-Vat Element Front Dual Vat 14kW
	823-5627	Support, Dual-Vat Element Front Dual Vat 17kW (used in some export 3-phase 4-wire WYE units)
16	810-3030	Spring, Element Lift Left
	810-3131	Spring, Element Lift Right
17	220-1190	Bracket, Lower Spring Single Foot Print
	220-0464	Bracket, Lower Spring
18	220-0733	Bracket, Lower Spring Mating

* Not illustrated.

2.4.4.2 Element Tube Assemblies

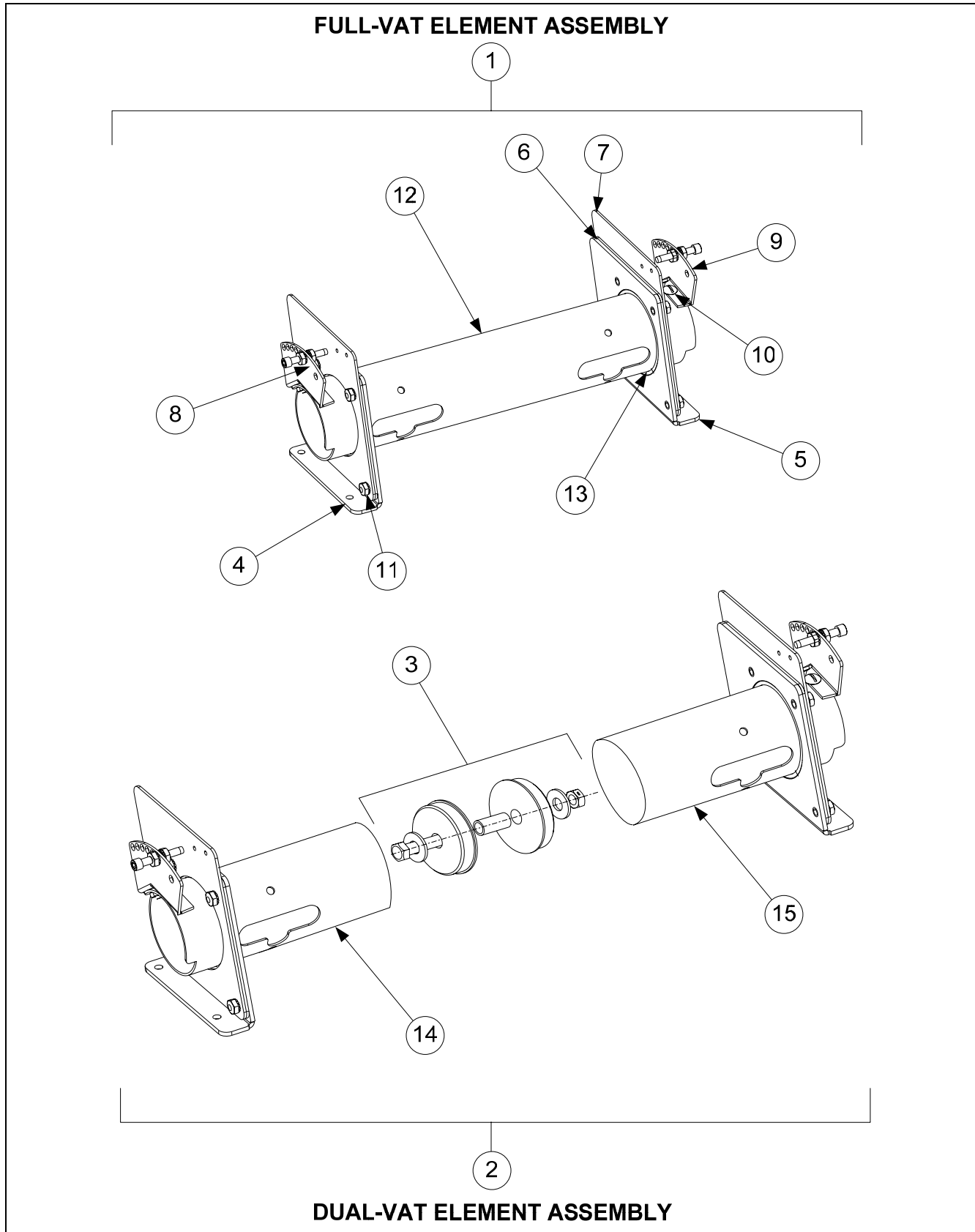

2.4.4.2 Element Tube Assemblies contd.

ITEM	PART #	COMPONENT
1	106-5374	Tube Assembly RE Element, Full-Vat
2	106-5457	Tube Assembly RE Element, Dual-Vat
3	106-5438	Bushing Assembly, Center Tube RE, Dual-Vat
	809-0996	Bolt, Stand Hex 1 1/2" x 3/8" - 16
	809-0998	Washer, 3/8" SAE
	809-0999	Nut, 3/8" 16, 2-Way Lock 18-8
	810-2996	Bushing, Aluminum DV Tube
	810-3013	Spacer, RE DV Bushing
4	106-5329	Bracket Assembly, LH Element Tube Support
5	106-5330	Bracket Assembly, RH Element Tube Support
6	220-0122	Plate, Element Tube Support Inner
7	220-0123	Plate, Element Tube Support Outer
8	106-6569	Bracket Assembly, LH Upper Spring
9	106-6570	Bracket Assembly, RH Upper Spring
10	826-1330	Screw, 10-32 X 3/8-inch Slotted Truss Head (Pkg. of 25)
11	809-0766	Nut, 10-32 Hex HD SS
12	106-6037	Tube, FV Element Mounting
13	810-2993	Bushing, Tube End Teflon
14	106-6038	Tube, DV Element Mounting, LH
15	106-6039	Tube, DV Element Mounting, RH
*	106-6587	Magnetic Position Sensor Assembly
*	826-2228	Magnetic Position Sensor Assembly with Bracket
*	810-3007	Magnet
*	230-0794	Bracket, Magnetic Position Sensor Wire

* Not illustrated.

2.4.5 Computers

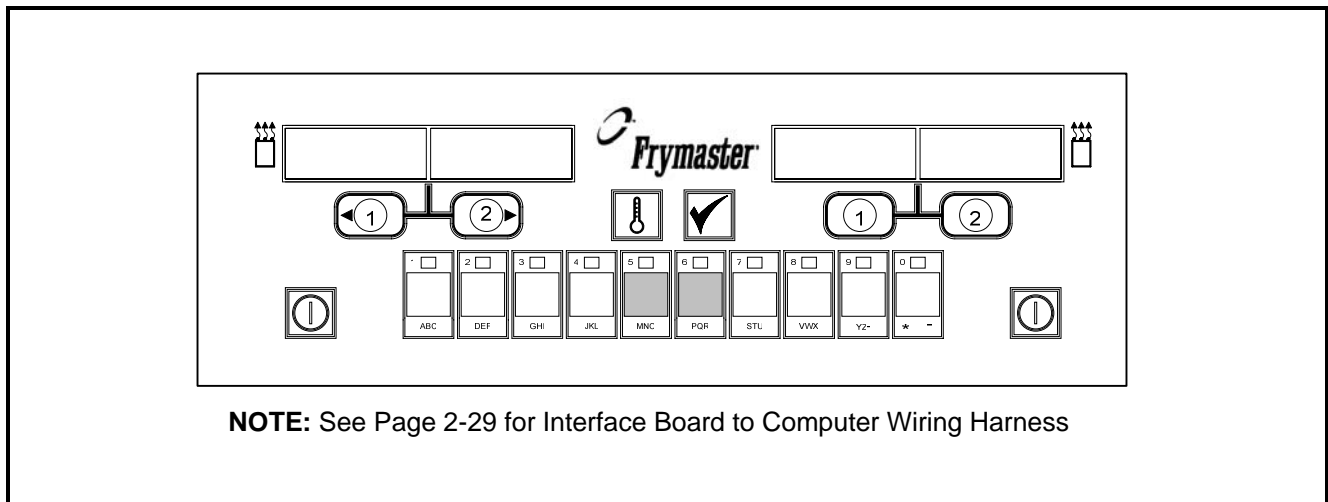

ITEM	PART #	COMPONENT
		Replacement Computer
	106-1269	Non-CE Domestic M2000
	106-0672	CE M2000

2.4.6 Wiring

2.4.6.1 Contactor Box Wiring Assemblies – 12-Pin Dual-Vat C-1

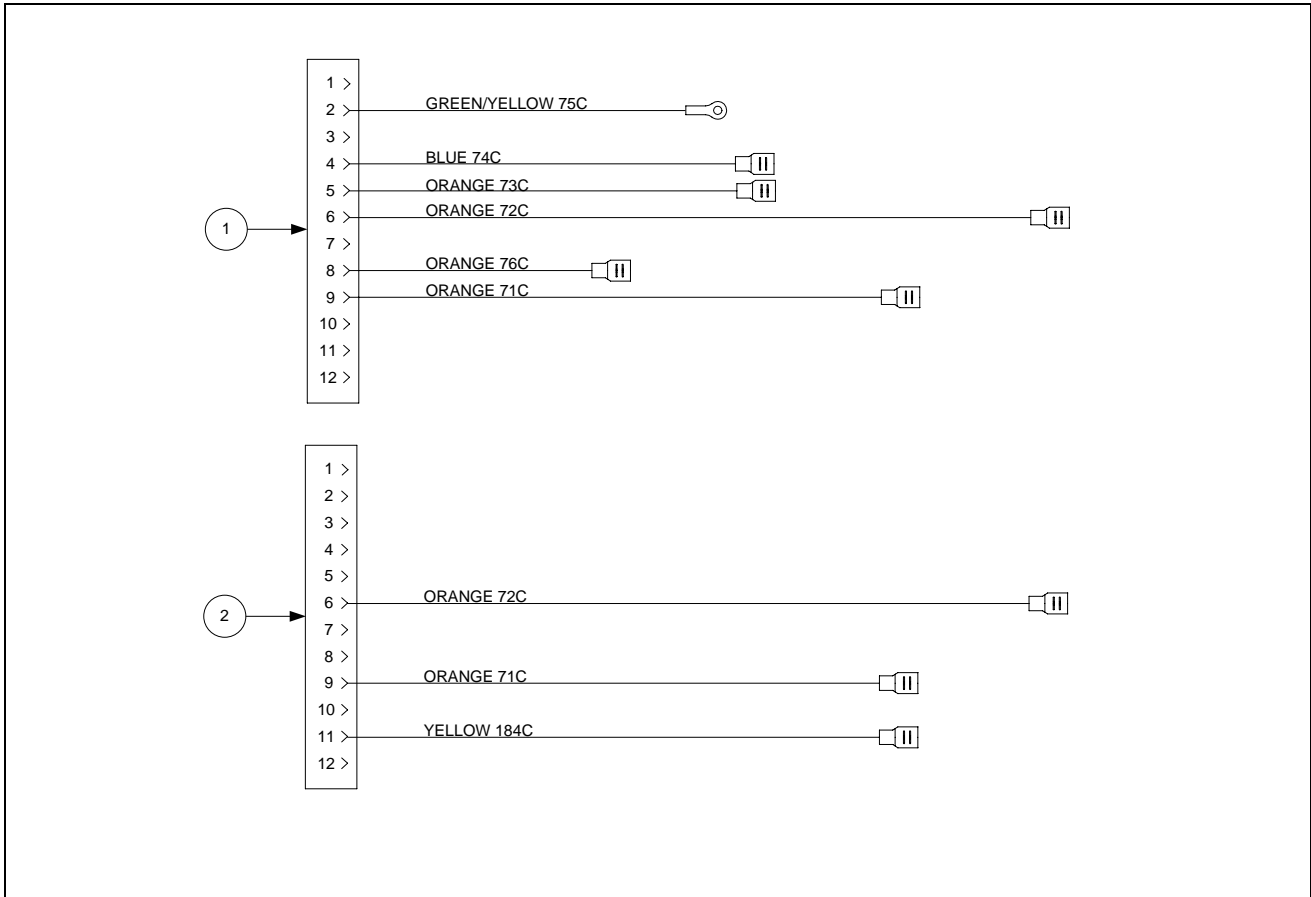

ITEM	PART #	COMPONENT
	106-5980	Contactor Box Harness Assembly Dual Vat
1		Standard
2		EPRI

2.4.6.2 Contactor Box Wiring Assemblies – 12-Pin Full-Vat C-1

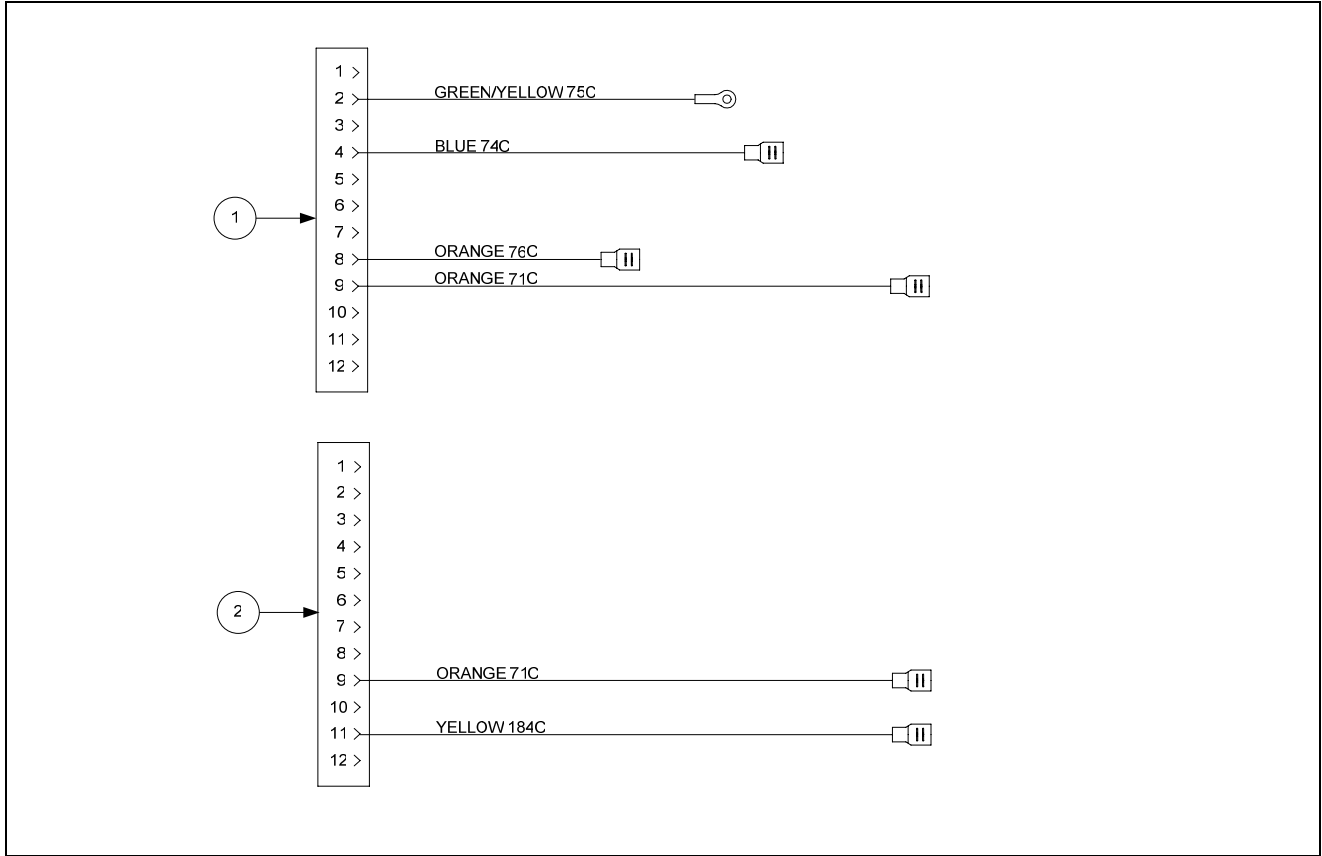

ITEM	PART #	COMPONENT
	106-6031	Contactor Box Harness Assembly Full Vat
1		Standard
2		EPRI

2.4.6.3 Contactor Box Wiring Assembly – 6-Pin (Left Element)

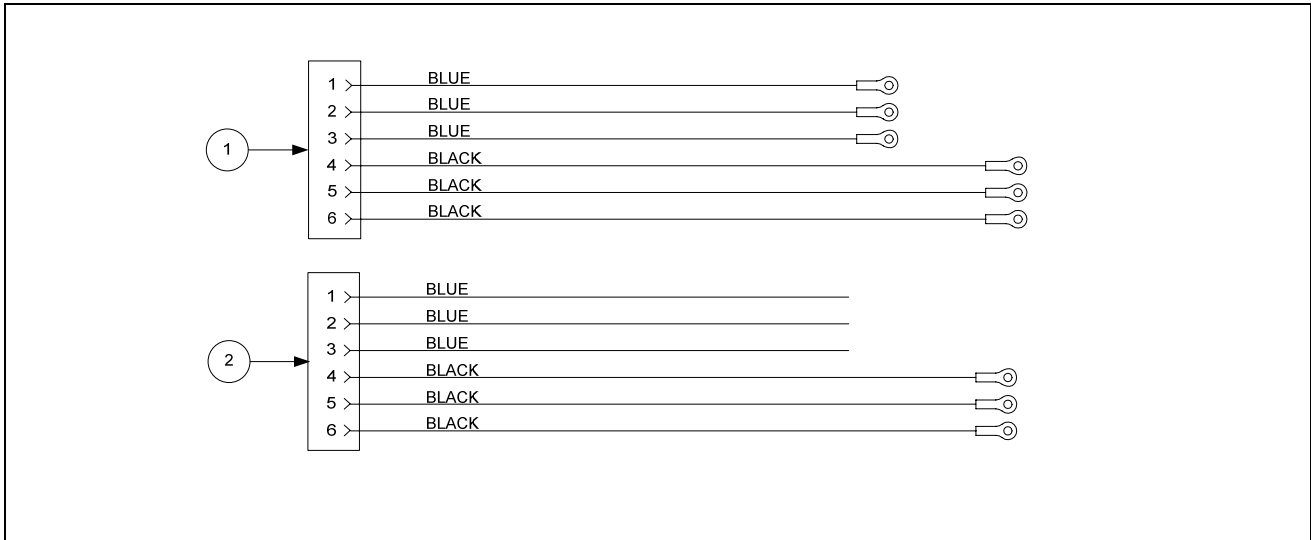

ITEM	PART #	COMPONENT
1	106-6768	14/17 kW Mercury Contactor
2	106-6771	14/17 kW Mechanical Contactor

2.4.6.4 Contactor Box Wiring Assembly – 9-Pin (Right Element)

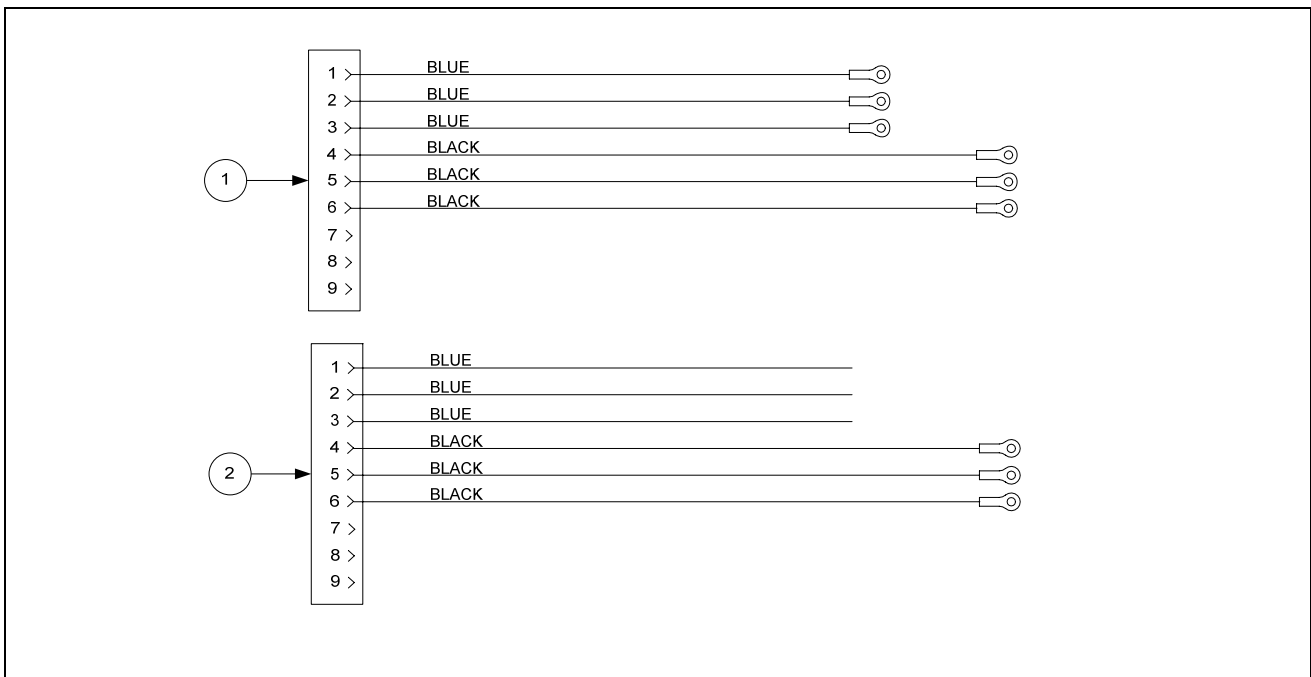

ITEM	PART #	COMPONENT
1	106-6769	14/17 kW Mercury Contactor
2	106-6772	14/17 kW Mechanical Contactor

2.4.6.5 Main Wiring Harnesses

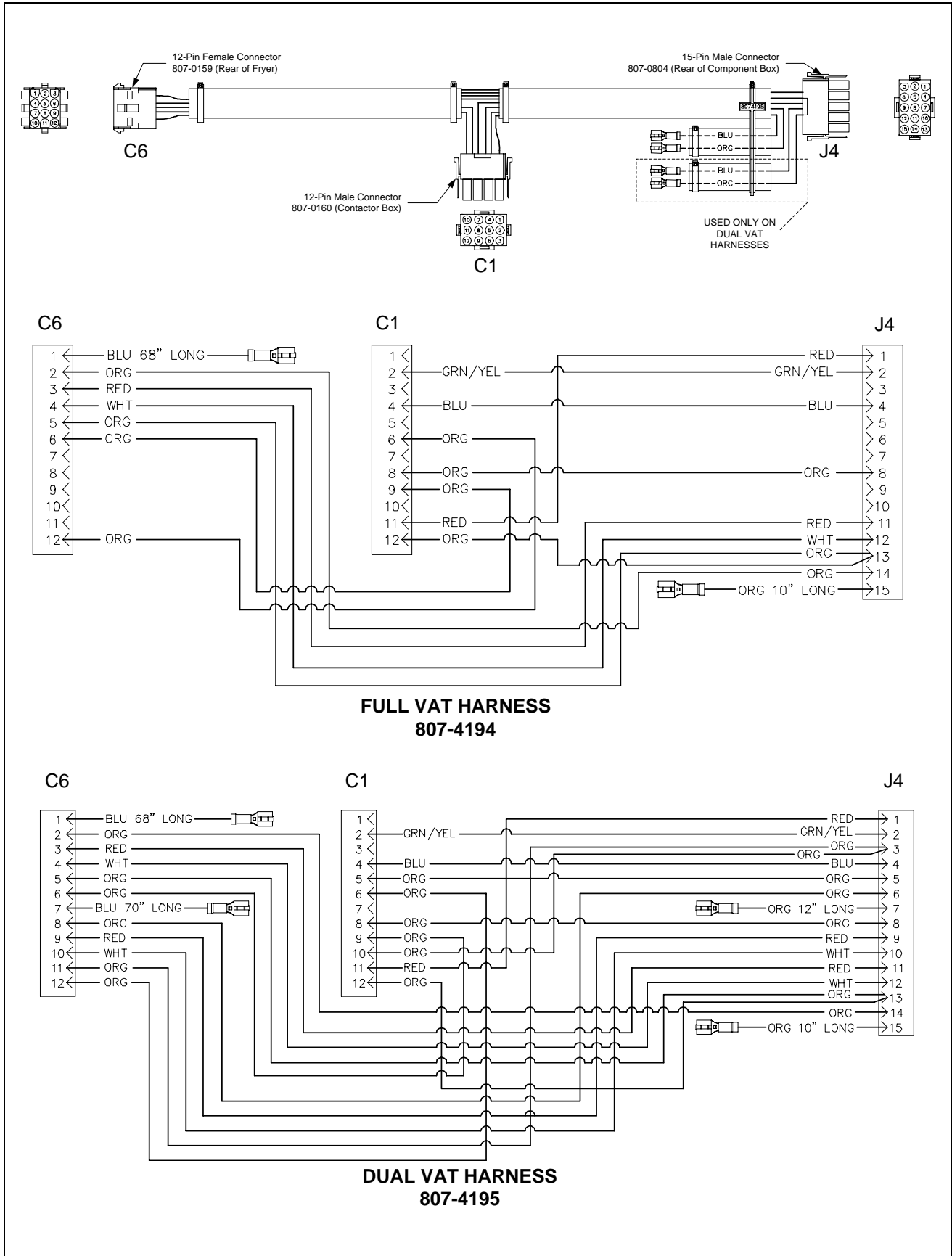

2.4.6.6 Component Box and Filter Pump Wiring Harnesses

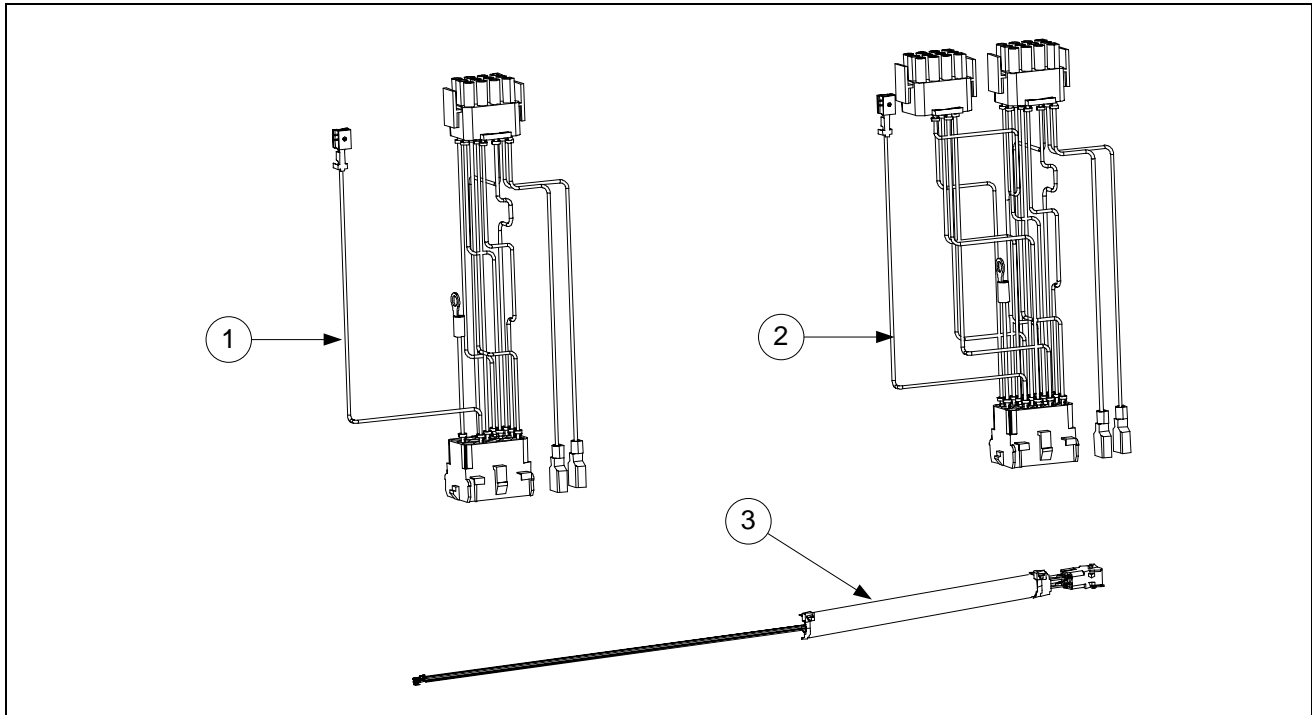

ITEM	PART #	COMPONENT
1	106-5750	Full Vat Control Harness J4 to J2 (<i>Standard</i>)
	106-6639	Full Vat Control Harness J4 to J2 (<i>EPRI</i>)
2	106-5751	Dual Vat Control Harness J4 to J1 and J2 (<i>Standard</i>)
	106-6644	Dual Vat Control Harness J4 to J1 and J2 (<i>EPRI</i>)
3	106-5935	Filter Pump C2 to Component Box Wiring Harness

2.4.6.7 Component Box to Filter Pump Harness

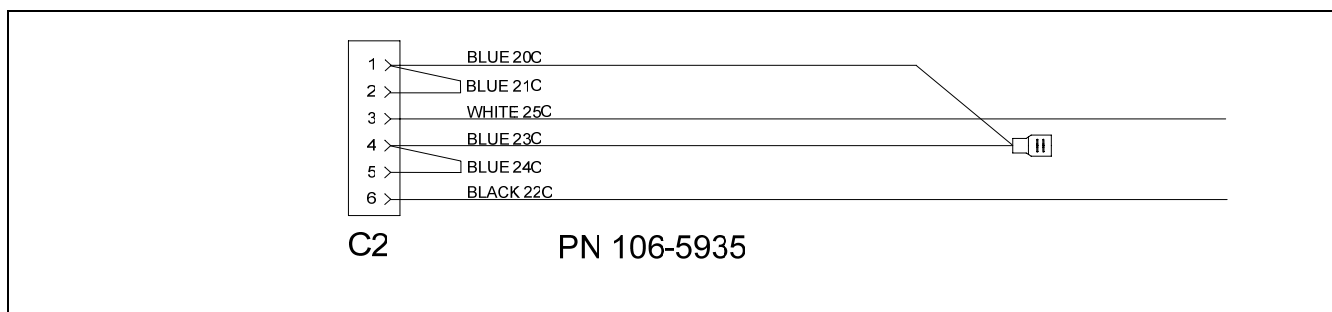

2.4.6.8 Interface Board to Controller Wiring Harness – 15-Pin

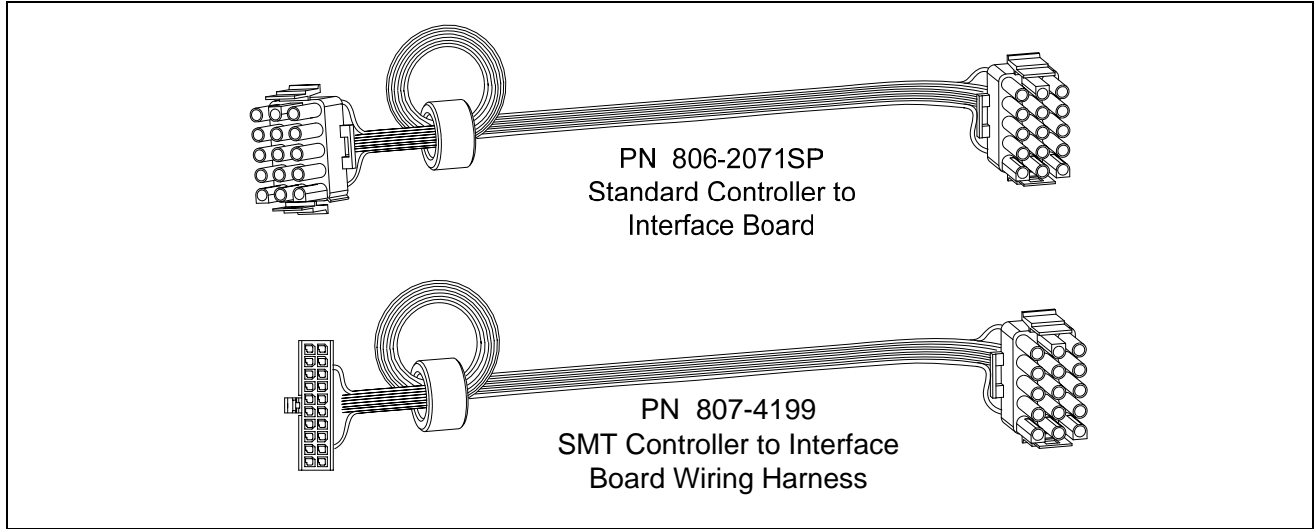

2.5 Filtration System Components

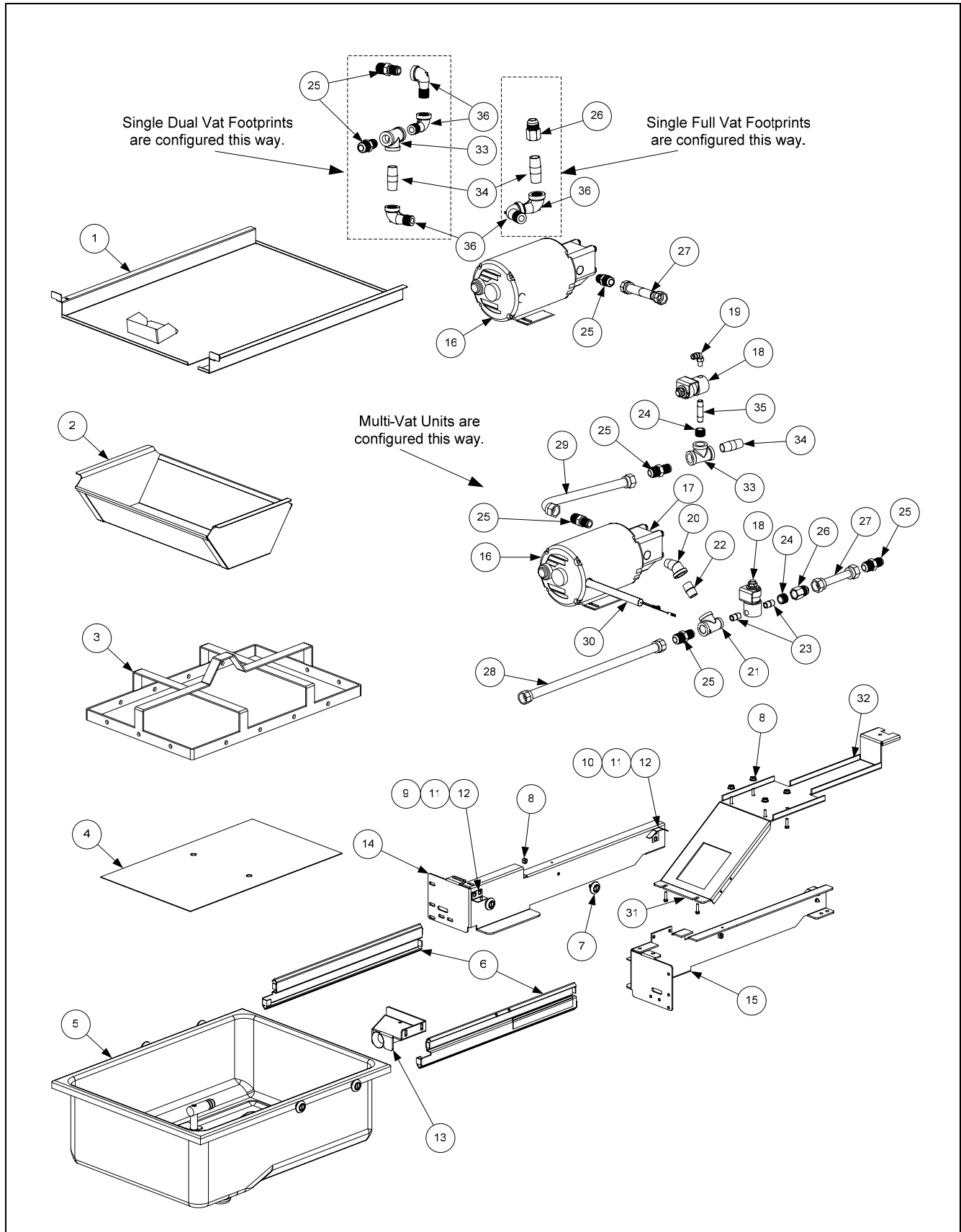

2.5 Filtration System Components cont.

ITEM	PART #	COMPONENT
*	826-1979	Filter Pan Roller Kit (four each of Items 7 and 8)
*	826-1980	Service Filter Pan (Item 5, four of Items 7 & 8, two O-rings and two of 813-0568)
*	826-1981	Service Filter Pan Assembly (Service Filter Pan plus Items 3 and 4)
*	826-1392	O-Ring (Pkg. of 5; used with Item 5)
*	813-0568	Plug, 1/8-inch Socket Head Pipe (used with Item 5; two required)
*	106-5911	Heater Strip Assembly, 100-120V 25W 18"
*	106-5912	Heater Strip Assembly, 208-250V 25W 18"
1	823-4637	Lid, Multi-Vat Fryers
	106-6243	Lid, Single Station Fryer Only Full Vat
	106-6310	Lid, Single Station Fryer Only Dual Vat
2	810-2874	Crumb Tray
	824-1707	Crumb Tray, Single Station Fryer Only
3	810-2909	Hold-Down Ring for Pad 11.20 x 19.10
	810-2910	Hold-Down Ring for Paper 13.65 x 21.41
	823-5774	Hold-Down Ring for Paper 8.98 x 19.39 Single Station Fryer Only
4	200-2124	SanaGrid Filter Screen
	220-1316	SanaGrid Filter Screen, Single Station Fryer Only
5	106-2617SP	Pan, One-Piece Filter (includes Item 2,)
	823-5594	Pan, One-Piece Filter Single Station Fryer Only
6	810-2012	Rail Set, Filter Pan Roller (includes one left and one right)
	826-1979	Kit, Roller (<i>includes 4 rollers, 4 nuts and 4 lock washers</i>)
7	810-2198	Roller, Filter Pan and Rail
8	826-1372	Nut, 1/4-20 Hex Flange (Pkg. of 10) (<i>use 809-0191 for lock washers</i>)
9	823-4589	Bracket, Lid Support
10		Guide, Filter Pan Lid
	200-3556	Left
	200-6709	Right
11	826-1363	Screw, 8-32 X 1/2-inch Slotted Truss Head (Pkg. of 25)
12	809-0247	Nut, 8-32 Hex Keps
13	823-3879	Suction Tube
14	200-4408	Rail, Left Filter
	106-5981	Support Assembly, Left Single Station Fryer Only
15	200-4409	Rail, Right Filter
	106-5982	Support Assembly, Right Single Station Fryer Only
16		Motor and Gasket Kit
	826-1785	100V 50/60 Hz
	826-1712	115V 50/60 Hz
	826-1756	208V 50/60 Hz
	826-1270	220-240V 50/60 Hz
	826-1755	250V 50/60 Hz
17	826-1264	Pump and Gasket Kit 4 GPM 2 piece
	816-0093	Gasket, Pump/Motor
*	807-11973	Viking Pump Seal Kit

* Not illustrated.

Continued on next page...

2.5 Filtration System Components cont.

ITEM	PART #	COMPONENT
18	807-2484	Valve, 1/4-inch Solenoid
19	810-2493	Fitting, 1/4-inch x 90° Quick-Connect
*	811-1071	Tubing, 1/4-inch OD Teflon Vent (sold by the foot)
20	813-0342	Elbow, 1/2-inch 45° Street
21	813-0530	Tee, 1/2-inch X 1/4-inch X 1/2-inch Reducing
22	813-0022	Nipple, 1/2-inch Close
23	813-0838	Nipple, 1/4-inch Close
24	813-0304	Bushing, 1/2-inch to 1/4-inch Flush
25	810-1668	Adapter, 5/8-inch to 1/2-inch NPT Male
26	810-1669	Adapter, 5/8-inch to 1/2-inch NPT Female
27	810-1680	Flexline, 6.5-inch Oil Return
28	810-1057	Flexline, 13-inch Oil Return
29	810-1043	Flexline, 9.5-inch Oil Return
30		Wiring Harness, Filter Pump
	106-5910	115/120V Filter Harness
	106-5906	208/230/240/250V Filter Harness
31	826-1375	Screw, 10-32 X 3/4-inch Hex Trim Head (Pkg. of 5)
32	200-5950	Bridge, Filter Motor
	824-1705	Bridge Filter Single Station Fryer Only
33	813-0003	Tee, 1/2-Inch
34	813-0298	Nipple, 1/2-inch 2.0-inch
35	813-0537	Nipple, 1/4-inch 2.0-inch
36	813-0165	Elbow, ST 1/2-inch x 1/2-inch NPT 90° BM

2.6 Frypot Assemblies and Associated Parts

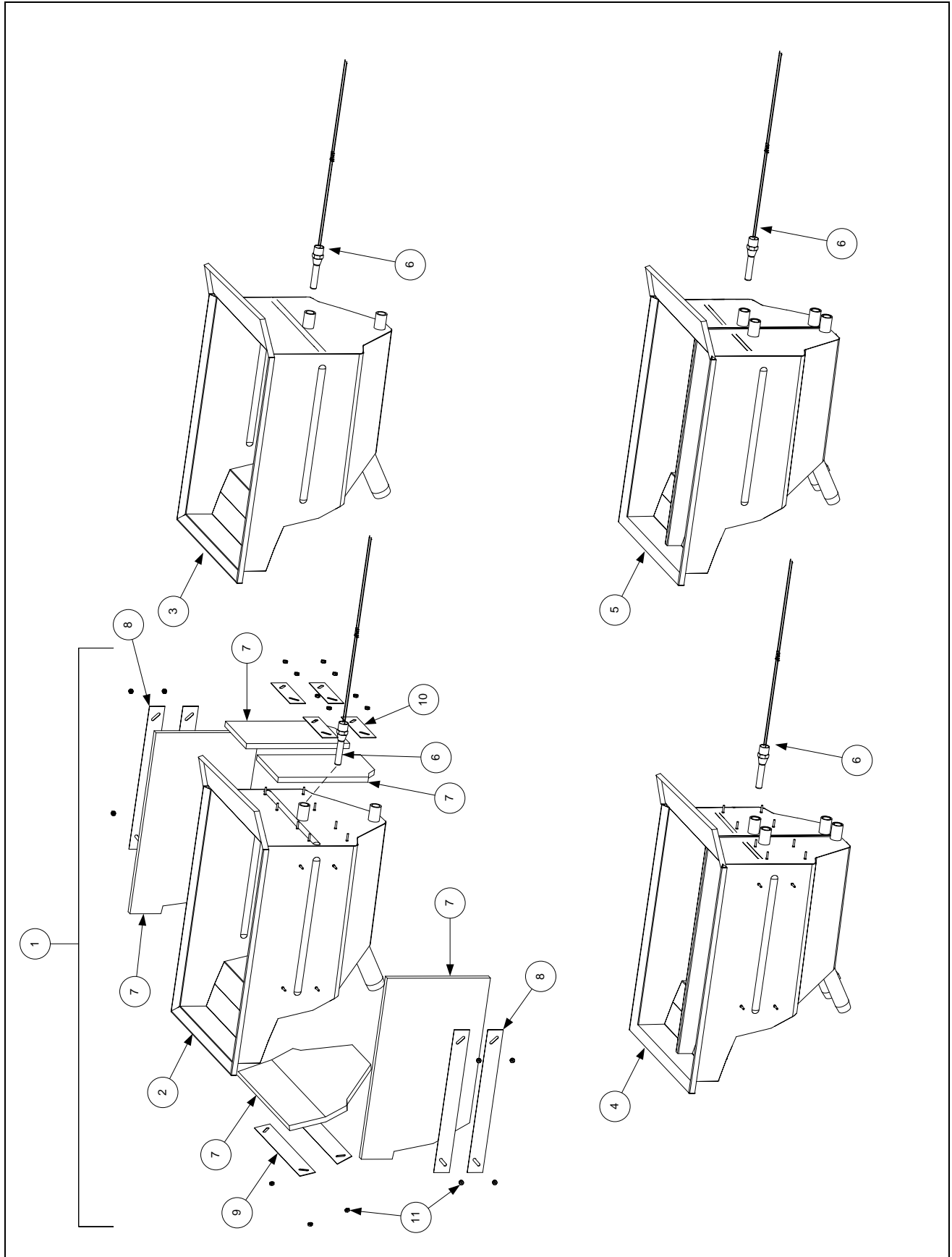

2.6 Frypot Assemblies and Associated Parts cont.

ITEM	PART #	COMPONENT
1		Frypot Assembly (<i>does not include Item 6</i>)
2	823-5545SP	Frypot, Full-Vat Filter with Insulation (<i>for use on EPRI units</i>)
3	823-5359SP	Frypot, Full-Vat Filter w/o Insulation (<i>for use on Standard units</i>)
4	823-5551SP	Frypot, Dual-Vat Non-Filter with Insulation (<i>for use on EPRI units</i>)
5	823-5482SP	Frypot, Dual-Vat Filter w/o Insulation (<i>for use on Standard units</i>)
6		Thermostat Assembly, High-Limit
	806-7543	Non-CE Full Vat 425°F (218°C) (17kW FV and 14kW FV) (Color Coded Black)
	806-8035	Non-CE Dual Vat 435°F (224°C) (22kW, 17kW DV and 14 kW DV) (Color Coded Red)
	806-8132	CE Full and Dual Vat 415°F (213°C) (14kW and 17kW CE) (Color-Coded Yellow)
7	812-0211	Insulation, Kaowool 17-inch X 10-inch X ½-inch (4 required per pot)
8	900-4100	Retainer, Side Insulation
9	900-4101	Retainer, Front Insulation
10	900-1345	Retainer, Rear Insulation
11	826-1376	Nut, 10-32 Keps Hex (Pkg. of 10)

NOTES: The frypots for EPRI-equipped units are insulated; those for non-EPRI (standard) units are not. EPRI frypot assemblies 806-5545SP and 806-5551SP consist of the Items 2 and 4 respectively, plus insulation (Items 7-10). When replacing insulation or adding insulation to a bare frypot, the individual pieces (sides, front, and back) are cut to fit from Item 7 when installed. Each frypot requires four uncut pieces of insulation.

2.7 Oil Return System Components

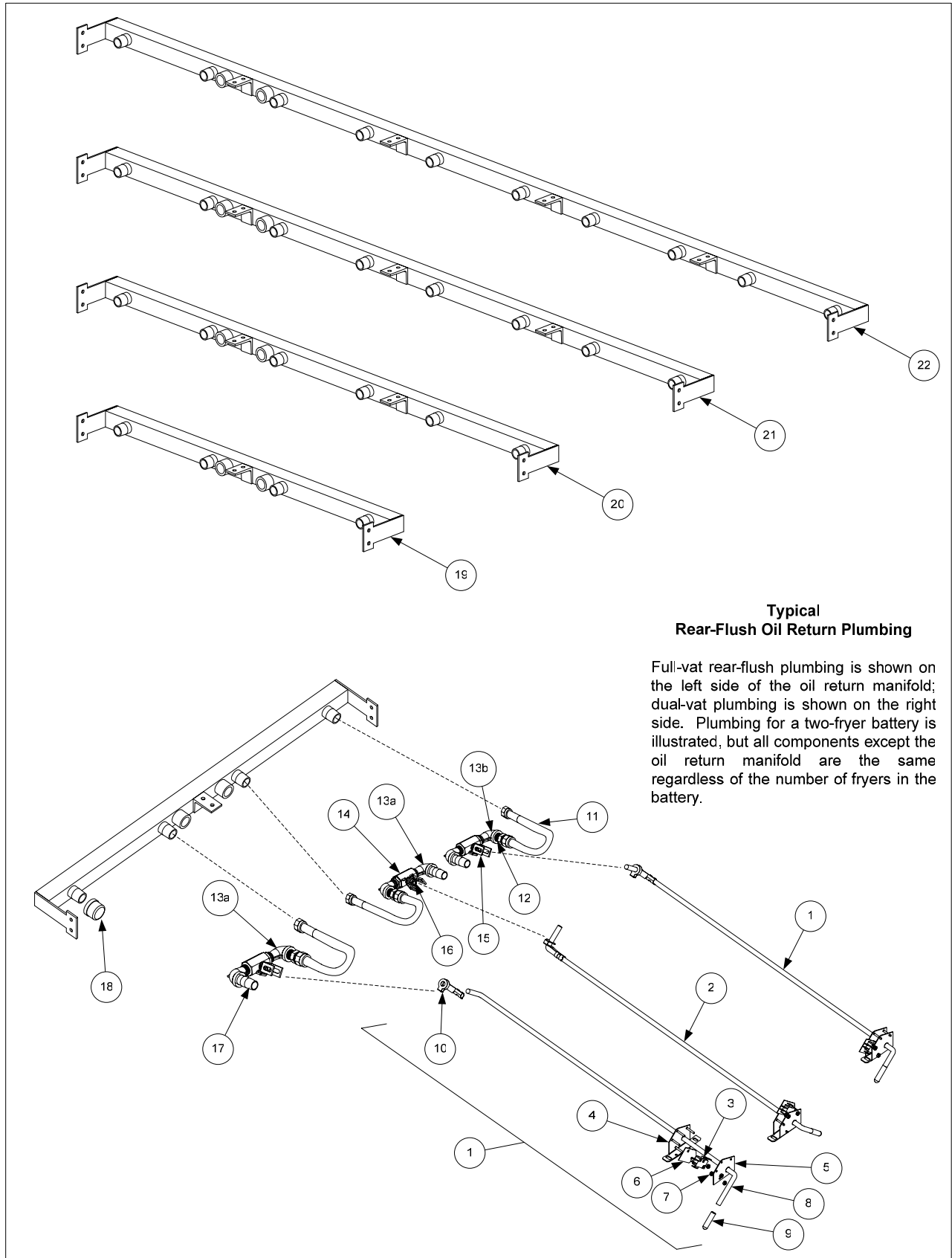

Typical Rear-Flush Oil Return Plumbing

Full-vat rear-flush plumbing is shown on the left side of the oil return manifold; dual-vat plumbing is shown on the right side. Plumbing for a two-fryer battery is illustrated, but all components except the oil return manifold are the same regardless of the number of fryers in the battery.

2.7 Oil Return System Components cont.

ITEM	PART #	COMPONENT
1	106-2465SP	Handle Assembly, Full-Vat and Right Dual-Vat Rear Flush Complete
2	106-2687SP	Handle Assembly, Left Dual-Vat Rear Flush Complete
3	807-2103	Microswitch, Straight Lever
4	106-3349	Bracket Assembly, Microswitch
5	200-5401	Bracket, Handle Retainer
6	816-0220	Insulation, Oil Return Microswitch
7	826-1366	Nut, 4-40 Keps Hex (Pkg. of 25)
8	810-2534	Rod, Full-Vat and Right Dual Vat Rear Flush
	810-2533	Rod, Left Dual Vat Rear Flush
9	816-0643	Grip, Oil Return Valve Handle
10	809-0601	Clip, Clevis
11	810-2532	Flexline, 7.0-inch
	810-1057	Flexline, 13.0-inch Single Footprint Only Full Vat and Dual Vat Left Side
	810-1055	Flexline, 11.5-inch Single Footprint Only Dual Vat Right Side
12	810-1668	Adapter, 5/8-inch to 1/2-inch NPT Male
13a	813-0165	Elbow, 1/2-inch X 90° Street
13b	813-0908	Adapter, 1/2-inch NPT M/T 90° (<i>used only on side next to cabinet</i>)
14	810-0278	Valve, 1/2-inch Ball
15	200-5438	Handle, Rear Flush Valve
16	900-2935	Retainer, Oil Return Valve Nut
17	813-0460	Nipple, 1/2-inch X 3.0-inch NPT
18	813-0907	Cap, 15/16-inch Valve Safety
19	810-3015	Manifold, Two-Station Fryer (<i>use 810-2543 for non-filter units</i>)
20	810-3016	Manifold, Three-Station Fryer (<i>use 810-2544 for non-filter units</i>)
21	810-3017	Manifold, Four-Station Fryer (<i>use 810-2545 for non-filter units</i>)
22	810-3018	Manifold, Five-Station Fryer (<i>use 810-2546 for non-filter units</i>)

2.8 Wiring Connectors, Pin Terminals, and Power Cords

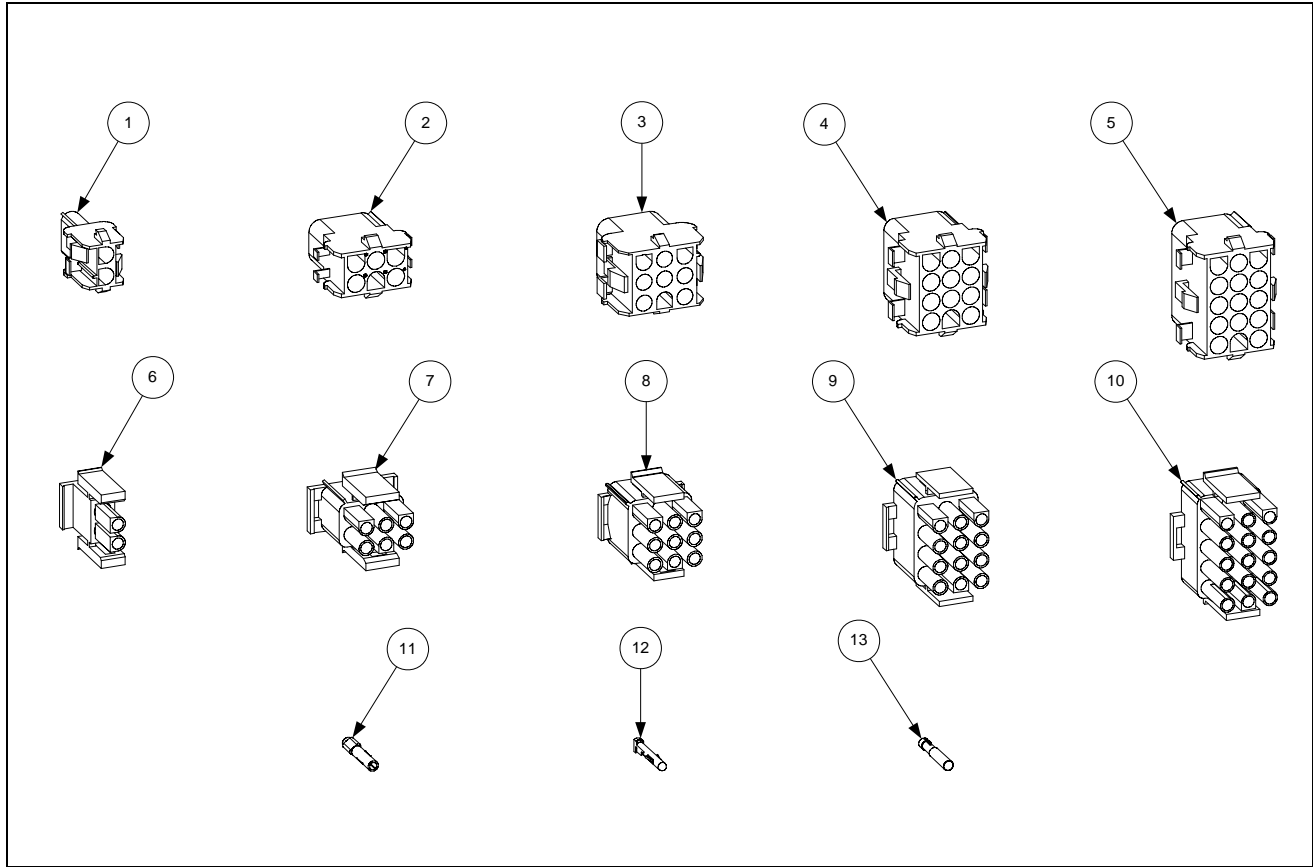

ITEM	PART #	COMPONENT
Power Cords		
*	807-0154	100/120V–15A 3-wire, w/grounded plug
*	807-4317	100/208/240V-16A 3-Wire with Plug BIRE/MRE CE
*	807-1685	100/208/240V–18A 3-wire, w/o plug
*	807-4316	120V 5-wire, w/grounded plug BIRE/MRE
*	807-3817	208/240V 3-Phase 4-wire w/grounded plug
Connectors		
1	807-1068	2-Pin Female
2	807-0158	6-Pin Female
3	807-0156	9-Pin Female
5	807-0159	12-Pin Female
5	807-0875	15-Pin Female
6	807-1067	2-Pin Male
7	807-0157	6-Pin Male
8	807-0155	9-Pin Male
9	807-0160	12-Pin Male
10	807-0804	15-Pin Male
11	826-1341	Terminal, Female Split Pin (Pkg of 25)
12	826-1342	Terminal, Male Split Pin (Pkg of 25)
13	807-2518	Plug, Mate-N-Lock (Dummy Pin)

* Not illustrated.

2.9 Fasteners

ITEM	PART #	COMPONENT
*	809-0429	Bolt, ¼-inch – 20 x 2.00-inch Hex Head ZP Tap
*	809-0514	Capscrew, 5/16-inch-18 NC Hex
*	809-0448	Clip, Tinnerman
*	826-1366	Nut, 4-40 Keps Hex (Pkg. of 25) (809-0237)
*	826-1358	Nut, 6-32 Keps Hex (Pkg. of 25) (809-0049)
*	809-0247	Nut, 8-32 Keps Hex
*	826-1376	Nut, 10-32 Keps Hex (Pkg. of 10) (809-0256)
*	809-0766	Nut, 10-32 Keps Hex SS
*	809-0581	Nut, ½ NPT Locking
*	809-0020	Nut Cap 10-24 NP
*	826-1372	Nut Grip ¼-inch 1/4-20 Hex NP (Pkg. of 10) (809-0059)
*	809-0417	Nut Flange ¼-inch 1/4-20 Serr
*	809-0535	Nut, "T" ¼-inch-20 x 7/16 SS
*	809-0540	Nut, Lock ½-inch-13 Hex 2-Way ZP
*	826-1359	Screw, 4-40 x ¾-inch Slotted Round Head (Pkg. of 25) (809-0354)
*	826-1365	Screw, 6-32 x ⅜-inch Slot Head (Pkg. of 25) (809-0095)
*	809-0357	Screw, 6 x ⅜-inch Phillips Head NP
*	809-0359	Screw, 8 x ¼-inch Hex Washer Head
*	809-0360	Screw, 8 x ⅜-inch Hex Washer Slot Head
*	826-1371	Screw, 8 x ½-inch Hex Head ZP (Pkg. of 25) (809-0361)
*	809-0364	Screw, 8 x ⅝-inch Hex Washer Head ZP
*	809-0518	Screw, 8-32 x ⅜-inch Hex Washer Slotted Head SS
*	809-0104	Screw, 8-32 x ½-inch Slotted Head ZP
*	826-1363	Screw, 8-32 x ½-inch NP (Pkg. of 25) (809-0103)
*	826-1360	Screw, 10-24 x 5/16-inch Round Slot Head ZP (Pkg. of 25) (809-0024)
*	826-1330	Screw, 10-32 x ⅜-inch Slot Head SS (809-0117)
*	809-1003	Screw, 10-32 x ⅜-inch Hex Trim Head SS
*	826-1375	Screw, 10-32 x ¾-inch Hex Trim Head SS (Pkg. of 5) (809-0401)
*	809-1000	Screw, 10-32 x 1¼-inch Hex Sck C/S
*	826-1374	Screw, 10 x ½-inch Hex Head (Pkg. of 25) (809-0412)
*	809-0266	Screw, 10 x ½-inch Phillips Head ZP
*	809-0434	Screw, 10 x ⅜-inch Hex Washer Head NP
*	809-0123	Screw, 10 x ¾-inch Slot Head
*	826-1389	Screw, 1/4-20 x ¾-inch Hex Head ZP (Pkg. of 10) (809-0131)
*	809-0582	Washer ½ NPT Locking
*	809-0184	Washer, #10 LK ZP
*	809-0190	Washer, .625 X .275 X 40 Flat SS
*	809-0191	Washer, Lock 1/4 Spring ZP
*	809-0193	Washer, Flat 1/4 Nylon
*	809-0194	Washer, Flat 5/16 ZP