

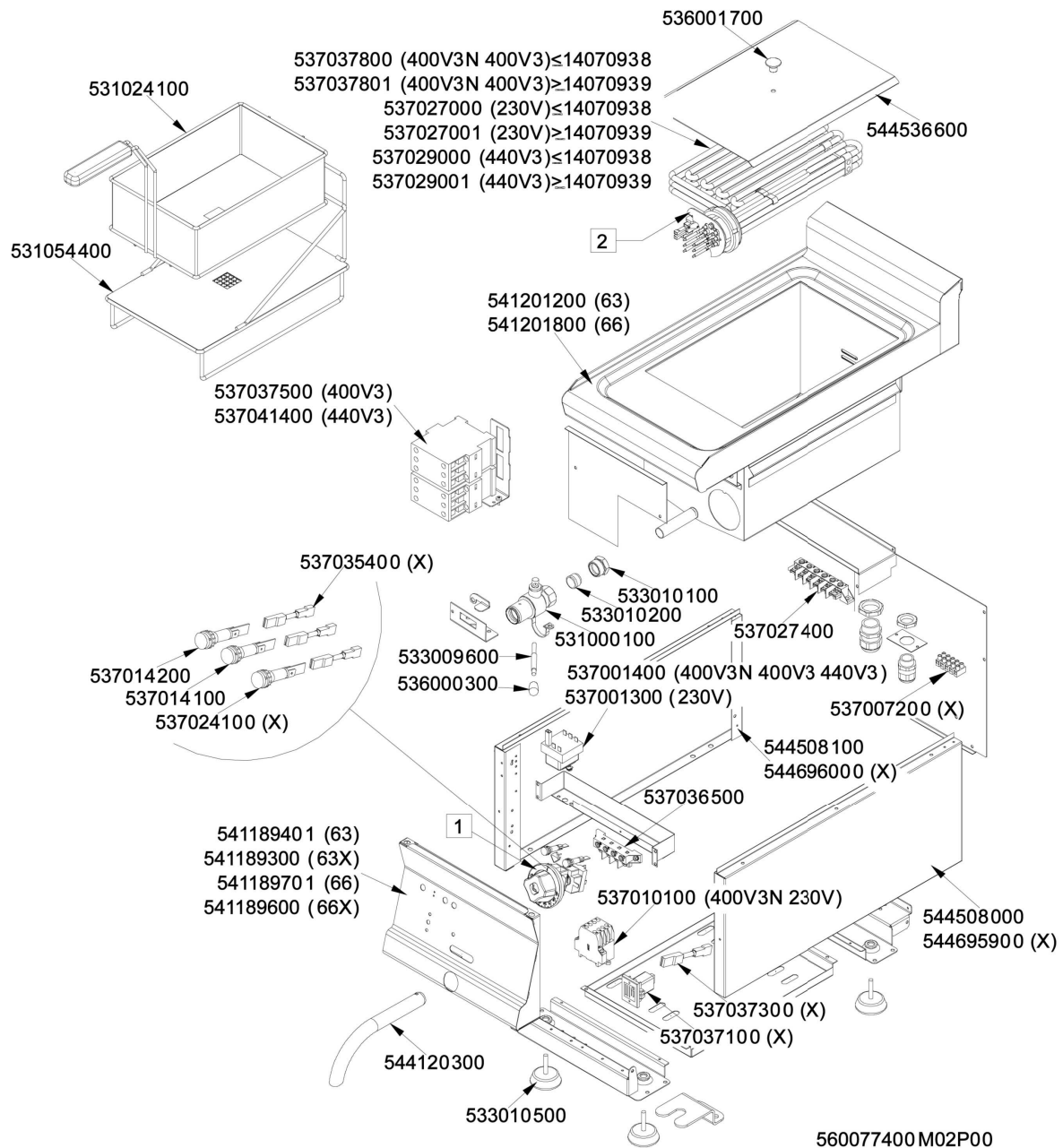

F2/10T-66ETX (SN>=1201<=1604)
Tav. 560077400M02P00





F2/10T-66ETX (SN>=1201<=1604) - FRIGGITRICI F2/10T-66ETX

Codice	Descrizione
536001700	IMPUGNAT.Ø25X19XM6
537037800	RES.COR.ROT.F S60T6600W 3-230V (S)
531024100	CESTO FQ 200X300X100 FQ-4/6/E/G
537037801	RES.COR.ROT.F S60T7150W 3-230V
537027000	RES.COR.ROT.FS60 3300W 1-230V (S)
537027001	RES.COR.ROT.FS60 4000W 1-230V
544536600	COP.VASCA F10T-E
537029000	RES.COR.ROT.F S60T6600W 3-440V (S)
537029001	RES.COR.ROT.F S60T7150W 3-440V
531054400	FILTRO VASCA S.CESTO F10T-E S60T
531201800	CODICE IN ELABORAZIONE
537037500	TELER.20A 690V B.380V 50-60HZ NC
537041400	TELER.20A 690V B.460V 60HZ NC
537035400	RES.ELETTR.3W 330KOHM C/F
533010100	RACC.BIC.Ø18 3/4
533010200	BICONO RUBINETTO 531000100 Ø18
537027400	MORSETT.6 POLI 40A VITE-VITE
531000100	VALV.SFERA 3/4G F/ATT.B.
537014200	SPIA G.B.VERDE 250VAC F.M.
537014100	SPIA G.B.BIANC.250VAC F.M.
537024100	SPIA G.B.ROSSO 110VAC F.M. (T)
533009600	MANIGLIA SCAR.RUB.3/4G S60
536000300	IMPUGNAT.Ø15X25XM6
537001400	TERMOST.SIC.TRIF. 245°C
537001300	TERMOST.SIC.MONOF.237°C C/DADO
537007200	MORSETT. 5 POLI PA 27WP NY (T)
544508100	FIANCO APP.S60T SX
544696000	FIANCO APP.S60TX SX
537036500	MORSETT.4 POLI 40A VITE-VITE
541189600	ASS.CRUSC.S607090 F2/10T-66ETX
537010100	TELER.20A 600V B.230V 50-60HZ NC
544508000	FIANCO APP.S60T DX
544695900	FIANCO APP.S60TX DX
537037300	RES.ELETTR.3W 056KOHM C/F
537037100	SEGNALATORE ACUSTICO 230VAC
533010500	PIEDE Ø50 017-042 M10 PLAST.
-	-
-	-



COMPONENTI COMUNI COMANDO_F-E
Tav. 560100200M01P00

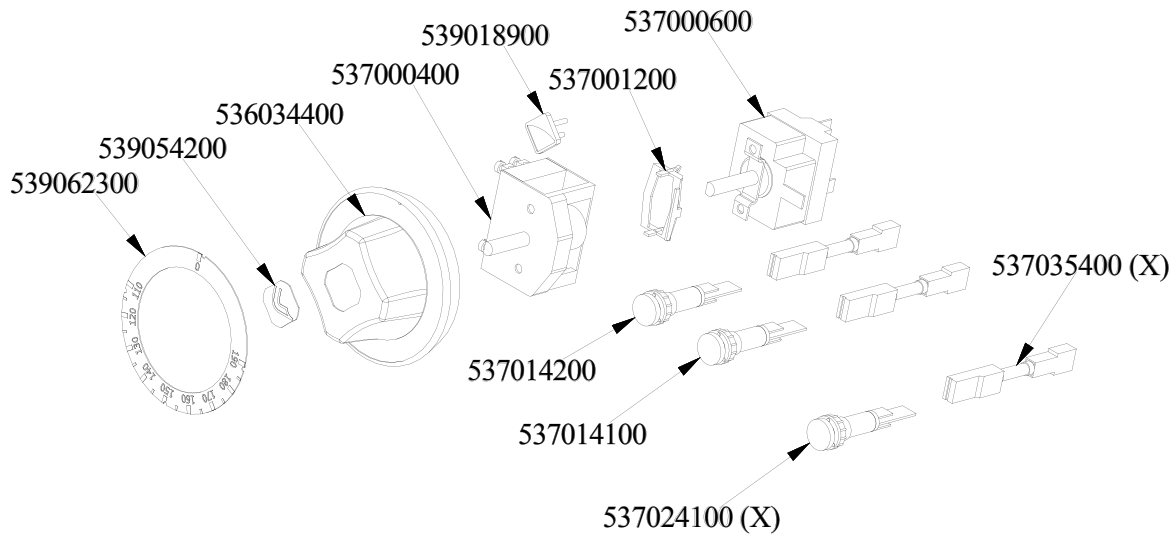

560100200M01P 00



COMPONENTI COMUNI COMANDO_F-E - COMPONENTI COMUNI COMANDO_F-E

Codice	Descrizione
537000600	TERMOST.F.MONOF.095-182°C GAMB.C
539018900	INDICE MAN.C/FRECCIA ROSSA
537000400	COMM.1 POS.1F 16A
537001200	STAFF.FISS.COMM.S49 TERMOST.3,5
536034400	MANOP.Ø77 4 P.Ø06X4,6 NERO C/M
539054200	BOLLINO Ø20,3 CR."L" LOTUS R.
539062300	DISC.72.FQ-E R. (110,190°)
537035400	RES.ELETTR.3W 330KOHM C/F
537014200	SPIA G.B.VERDE 250VAC F.M.
537014100	SPIA G.B.BIANC.250VAC F.M.
537024100	SPIA G.B.ROSSO 110VAC F.M. (T)



COMPONENTI COMUNI BOCCOLA RESISTENZA ROTATIVA
Tav. 560111000M00P00

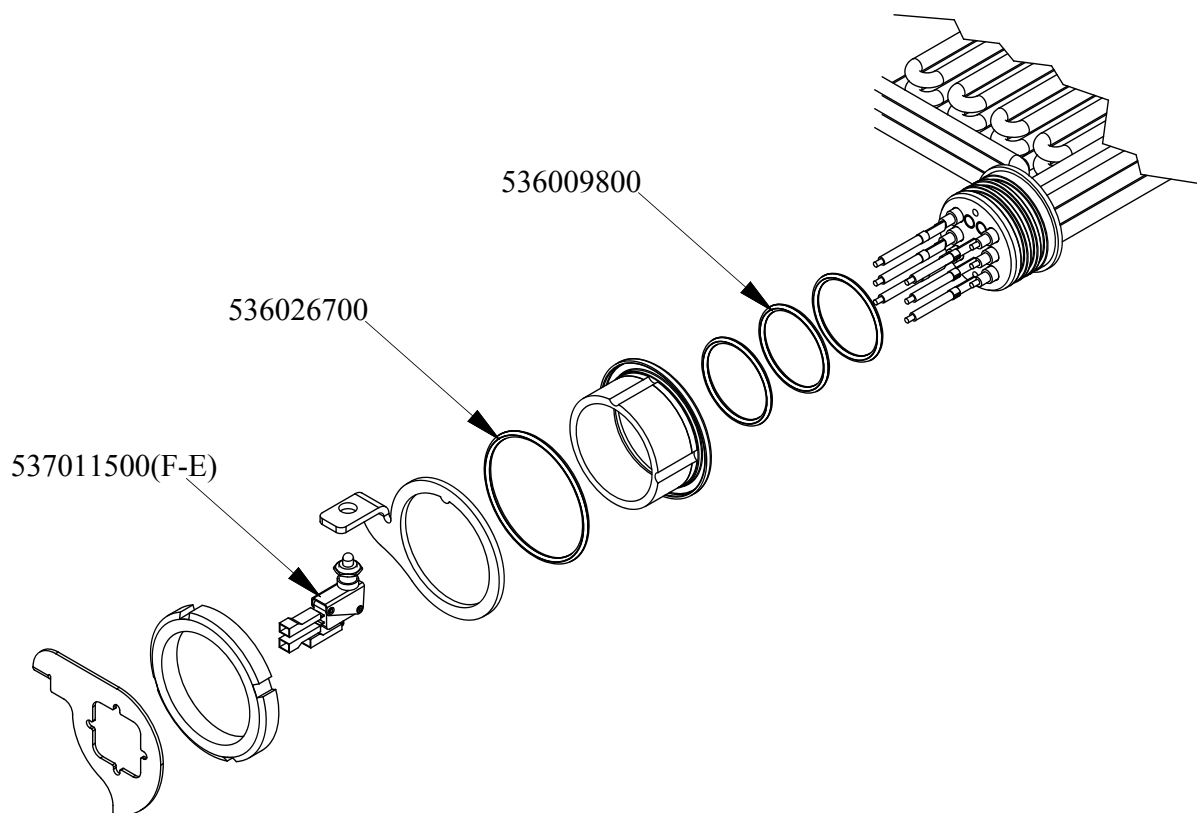

560111000M00P00



COMPONENTI COMUNI BOCCOLA RESISTENZA ROTATIVA - COMP_03_10

Codice	Descrizione
536009800	GUARNIZ.O-RING 47,22X3,53 VITON
536026700	GUARNIZ.O-RING 74,61X3,53 VITON
537011500	MICROINTERRUTT.PULSANTE 16A 250V