

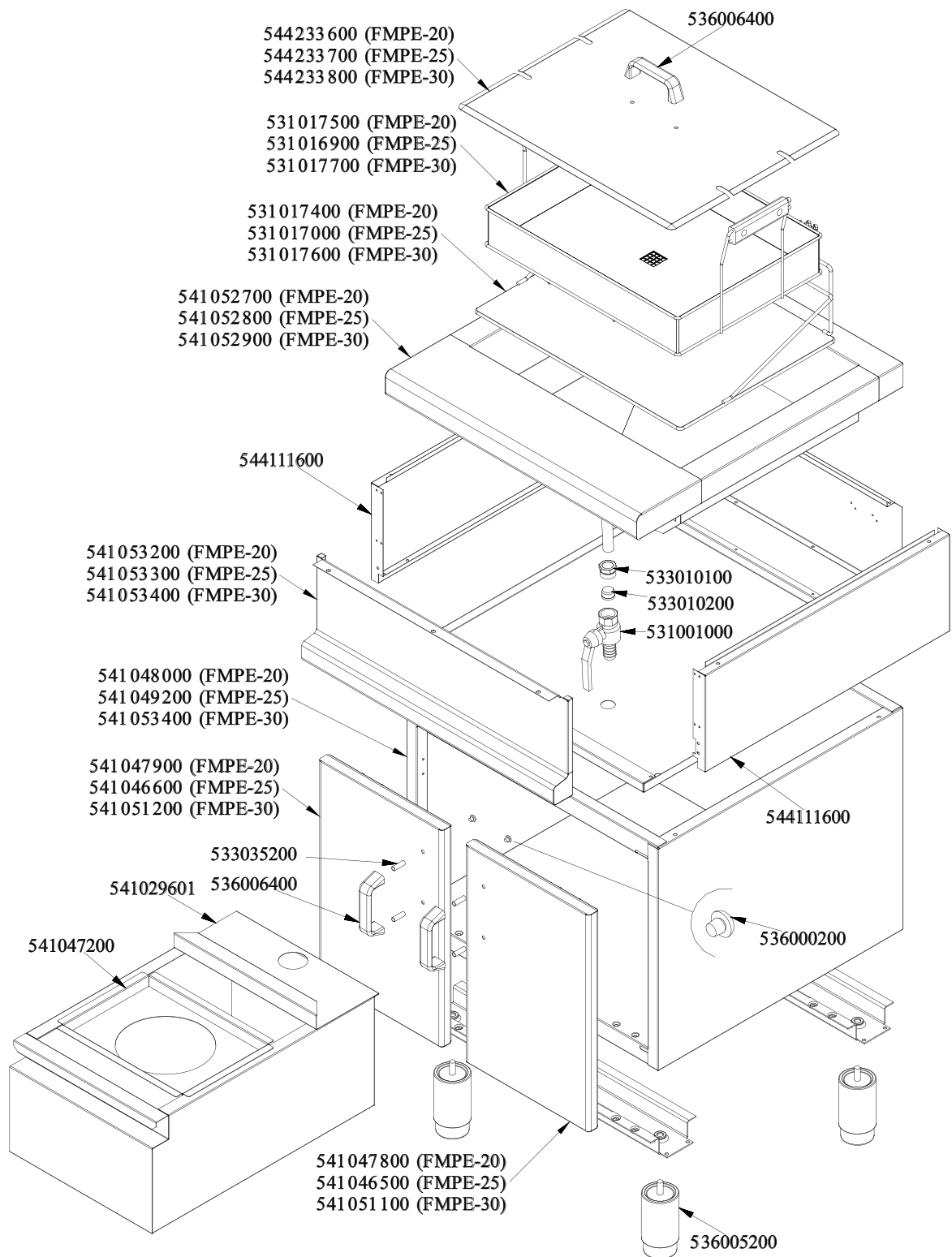

FMPE-30  
Tav. 560008401M00P00



5600084 01M00P00



## FMPE-30 - FRIGGITRICI PASTICCERIA FMPE-30

Codice	Descrizione
536006400	MANIGLIA S65 NERA
544233800	COP.VASCA FMPE-30
531017700	CESTO FP 864X349X080 (FMPE-30)
531017600	FILTRO VASCA S.CESTO FPE -30
541052900	ASS.PIANO FMPE-30
544111600	FIANCO APP.TOP 700
533010100	RACC.BIC.Ø18 3/4
533010200	BICONO RUBINETTO 531000100 Ø18
531001000	VALV.SFERA 3/4G F/PORTAG.
541053400	ASS.CRUSC.PAST.FMPE-30
541053400	ASS.CRUSC.PAST.FMPE-30
541051200	ASS.PORTA 5 SX
544111600	FIANCO APP.TOP 700
533035200	DIST.MANIGLIA S65 S70
536006400	MANIGLIA S65 NERA
541029600	ASS.BAC.RACC.OLIO 40LT (S)
536000200	PARACOLPI Ø12 H.4
541047200	ASS.FILTRO BAC.RACC.OLIO RETT.
541051100	ASS.PORTA 5 DX
536005200	PIEDE Ø2" 120-180 M10 INOX



FMPE-30  
Tav. 560036801M00P00

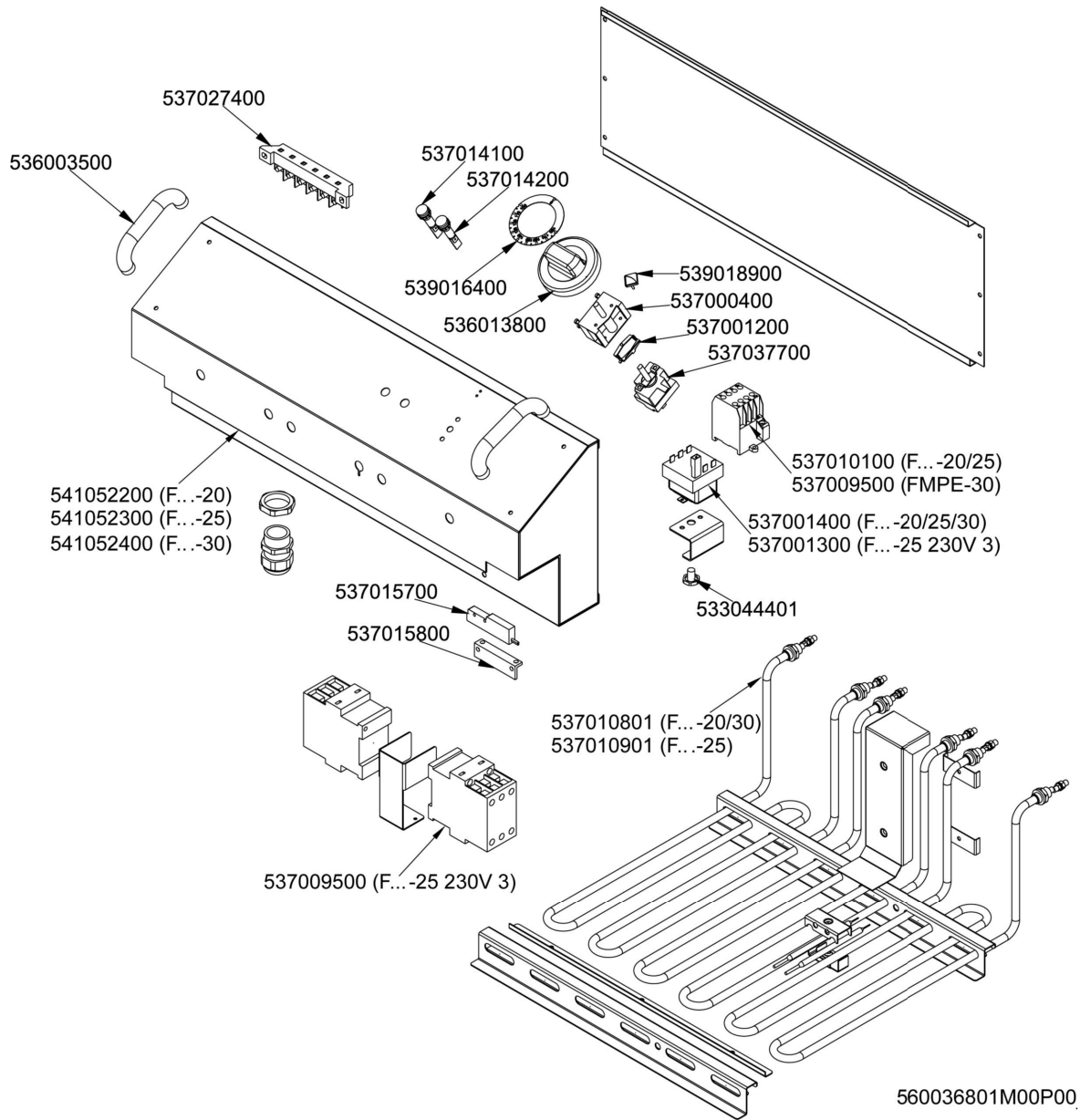



## FMPE-30 - FRIGGITRICI PASTICCERIA FMPE-30

Codice	Descrizione
537027400	MORSETT.6 POLI 40A VITE-VITE
537014100	SPIA G.B.BIANC.250VAC F.M.
536003500	MANIGLIA S60 ROSSA (S)
537014200	SPIA G.B.VERDE 250VAC F.M.
539018900	INDICE MAN.C/FRECCIA ROSSA
537000400	COMM.1 POS.1F 16A
537001200	STAFF.FISS.COMM.S49 TERMOST.3,5
537037700	TERMOST.F.MONOF.104-192°C GAMB.C
539016400	DISC.64.FQ-E R. (110,190°)
536003800	MANIGLIA S60 BLU (S)
537009500	TELER.35A 690V B.230V 50-60HZ --
537001400	TERMOST.SIC.TRIF. 245°C
533044401	TAPPO FILETTATO M8 INOX TS (S)
541052400	ASS.SCAT.COMAND.PAST.FMPE-30
537015700	SENSORE MAGNETICO INTERRUTTORE
537015800	UNITA' MAGNETICA SENSORE
537010801	RES.COR.FPE-20/30 2200W 1-230V