

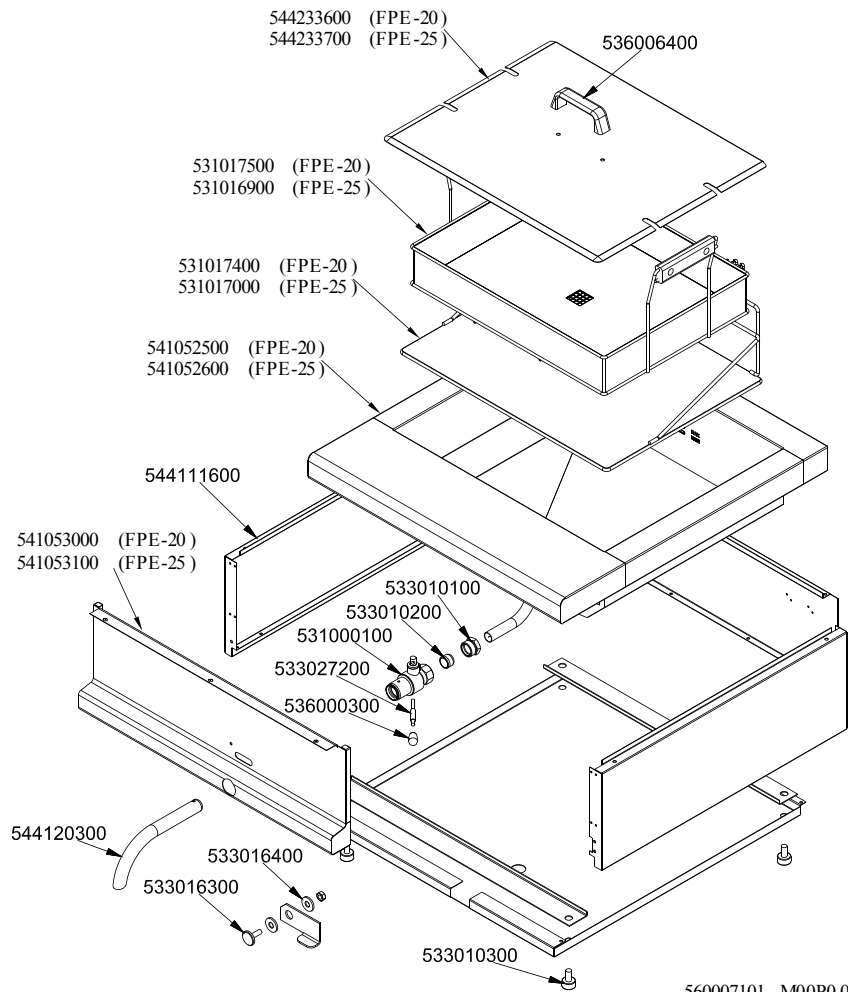

FPE-25  
Tav. 560007101M00P00





## FPE-25 - FRIGGITRICI PASTICCERIA FPE-25

Codice	Descrizione
544233700	COP.VASCA FPG-30 FPE-25
536006400	MANIGLIA S65 NERA
531016900	CESTO FP 664X349X075 FPE-25
531017000	FILTRO VASCA S.CESTO FPG -30
541052600	ASS.PIANO FPE-25
544111600	FIANCO APP.TOP 700
541053100	ASS.CRUSC.PAST.FPE-25
533010100	RACC.BIC.Ø18 3/4
533010200	BICONO RUBINETTO 531000100 Ø18
531000100	VALV.SFERA 3/4G F/ATT.B.
533027200	MANIGLIA SCAR.RUB.3/4G S65 (S)
536000300	IMPUGNAT.Ø15X25XM6
544120300	SCARICO RUBINETTO 3/4G PROLUNGA
533016400	BOCCOLA RUBINETTO
533016300	PERNO BOCCOLA RUB.
533010300	PIEDE Ø23 012-022 M10 PLAST.



FPE-25  
Tav. 560036801M00P00

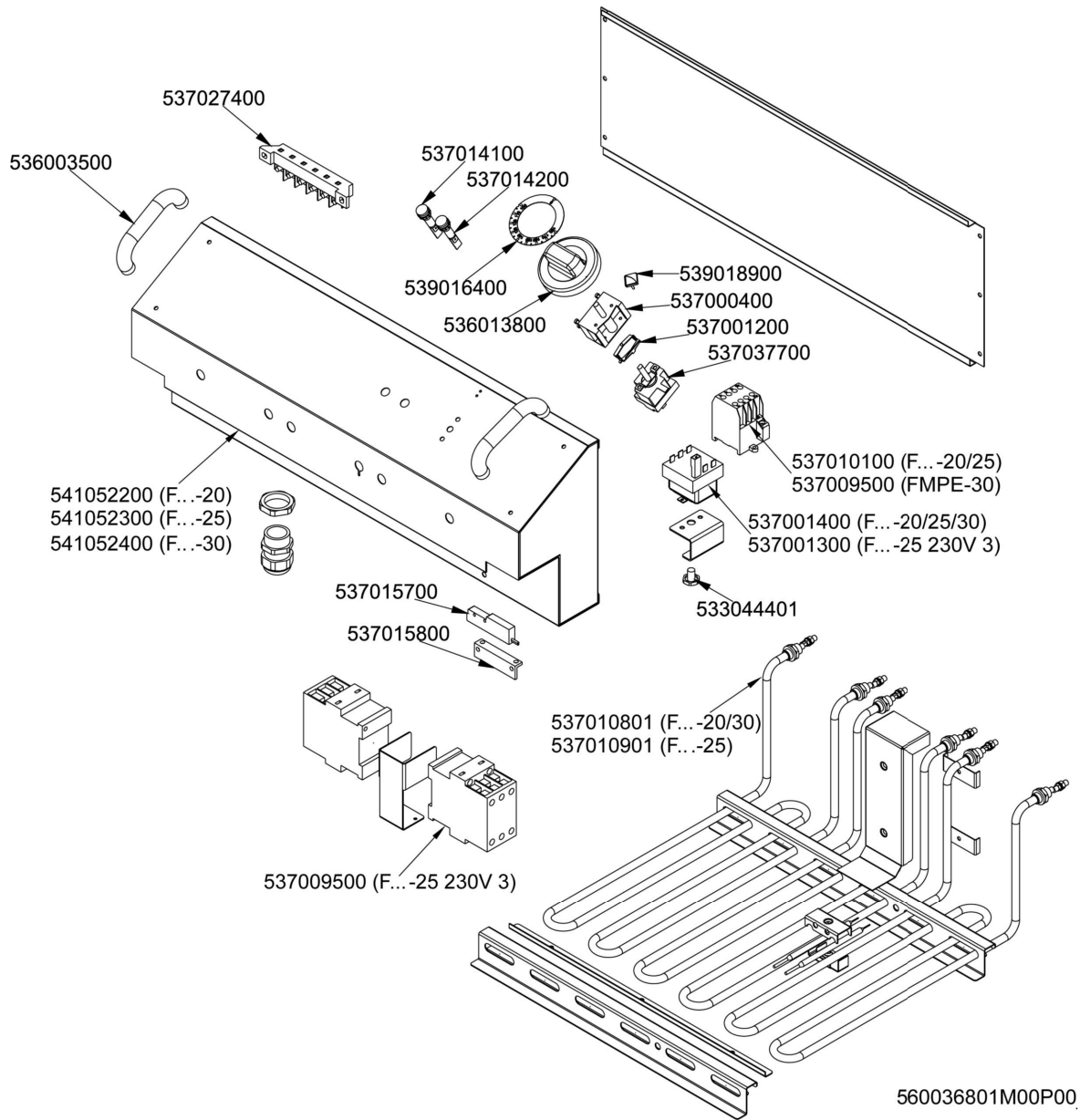



## FPE-25 - FRIGGITRICI PASTICCERIA FPE-25

Codice	Descrizione
537027400	MORSETT.6 POLI 40A VITE-VITE
537014100	SPIA G.B.BIANC.250VAC F.M.
536003500	MANIGLIA S60 ROSSA (S)
537014200	SPIA G.B.VERDE 250VAC F.M.
539016400	DISC.64.FQ-E R. (110,190°)
539018900	INDICE MAN.C/FRECCIA ROSSA
537000400	COMM.1 POS.1F 16A
536013800	MANOP.Ø70 PEL Ø06X5 SEDE PERP.
537001200	STAFF.FISS.COMM.S49 TERMOST.3,5
537037700	TERMOST.F.MONOF.104-192°C GAMB.C
537010100	TELER.20A 600V B.230V 50-60HZ NC
537001400	TERMOST.SIC.TRIF. 245°C
537001300	TERMOST.SIC.MONOF.237°C C/DADO
541052200	ASS.SCAT.COMAND.PAST.FPE-20
541052400	ASS.SCAT.COMAND.PAST.FMPE-30
537015800	UNITA' MAGNETICA SENSORE
533044401	TAPPO FILETTATO M8 INOX TS (S)
537010901	RES.COR.FPE-25 3400W 1-230V
537009500	TELER.35A 690V B.230V 50-60HZ --