

**magimix®**

**FRITEUSE  
PRO 500 T**

Sommaire / Summary



Autres appareils / Others

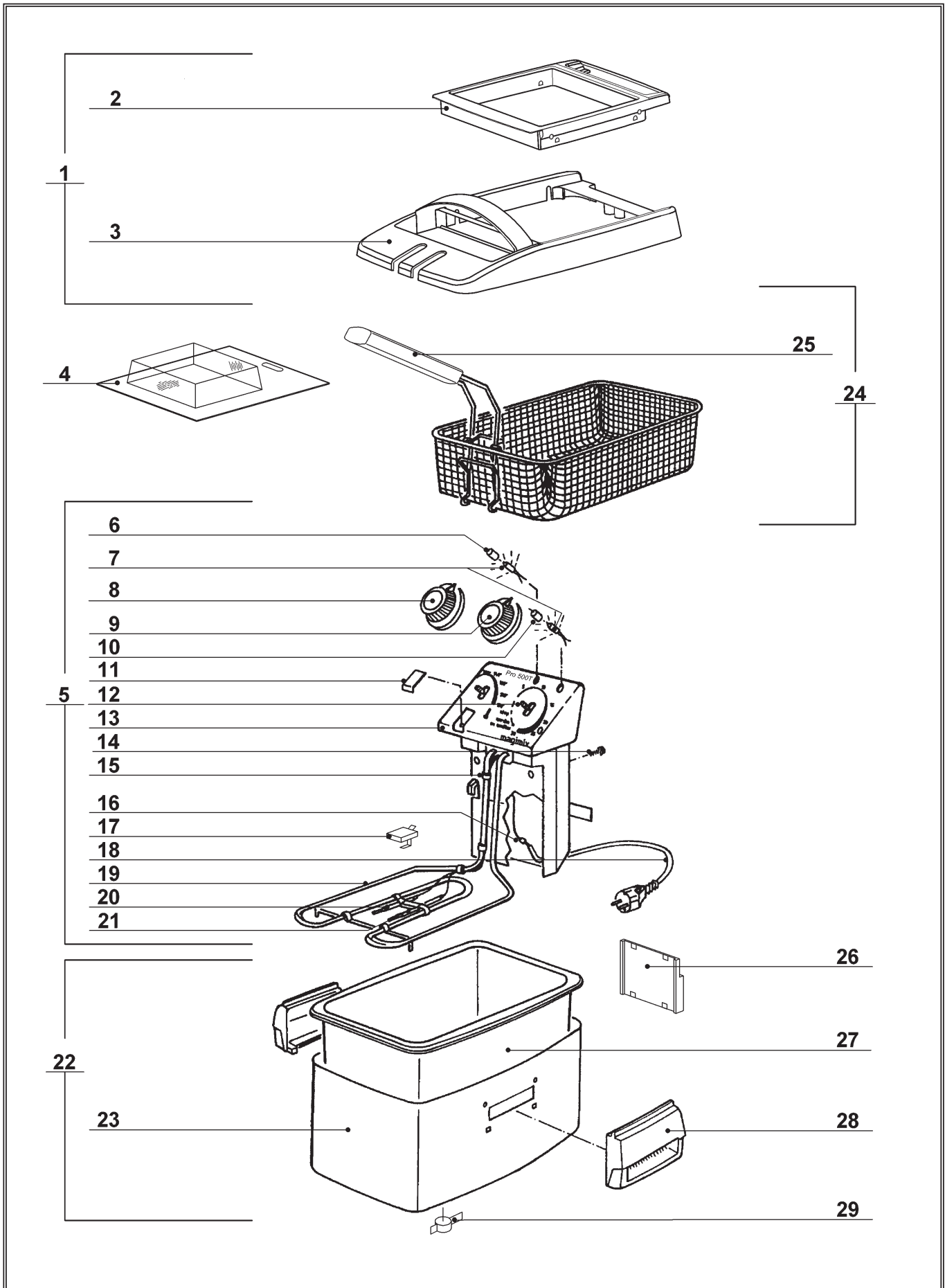

**magimix®****FRITEUSE  
PRO 500 T****11150**

<i>Index</i>	<i>Pièce / Part</i>	<i>Désignation</i>
1	<b>503 722</b>	COUVERCLE FILTRANT COMPLET SANS FILTRE
2	<b>503 724</b>	CASSETTE SANS FILTRE
3	<b>503 723</b>	COUVERCLE SANS CASSETTE
4	<b>17 027</b>	KIT BLISTER 2 FILTRES AU CHARBON ACTIF
5	<b>503 738</b>	BOITIER COMMANDE EQ. PRO500T+FACADE INOX
6	<b>502 872</b>	CABOCHON ORANGE
7	<b>502 874</b>	LAMPE TEMOIN
8	<b>502 555</b>	BOUTON
9	<b>503 735</b>	BOUTON MINUTERIE
10	<b>502 873</b>	CABOCHON ROUGE
11	<b>502 877</b>	LANGUETTE
12	<b>502 875</b>	MINUTERIE
13	<b>503 739</b>	BOITIER AVANT + FACADE INOX PRO 500T
14	<b>502 566</b>	VIS
15	<b>502 563</b>	CIRCLIPS
16	<b>502 565</b>	CONNEXION
17	<b>503 941</b>	INTERRUPTEUR PRESENCE DE CUVE
18	<b>503 743</b>	CORDON + FICHE CEE
19	<b>503 740</b>	ELEMENT DE CHAUFFE SEUL PRO500T 2700W
20	<b>502 543</b>	THERMOSTAT DE SECURITE
21	<b>502 547</b>	THERMOSTAT DE REGULATION
22	<b>503 745</b>	HABILLAGE CUVE EQUIPE COMPLET PRO500T
23	<b>503 744</b>	HABILLAGE CUVE PRO500T
24	<b>503 741</b>	PANIER PRO500T + POIGNEE
25	<b>503 728</b>	POIGNEE PLASTIQUE PANIER
26	<b>503 732</b>	GLISSIERE HABILLAGE CUVE
27	<b>503 742</b>	CUVE PRO500T AVEC GRAVURE
28	<b>502 576</b>	POIGNEE HABILLAGE CUVE
29	<b>503 733</b>	KIT DE 4 PIEDS + SUPPORTS