

NP70-10

Mod.  
**NF74E10T** CR0951810  
**NF76E10T** CR0951820  
**NF74E10TK** CR0851220  
**NF76E10TK** CR0851230

FRIGGITRICI ELETTRICHE 10+10 LITRI  
 ELECTRIC HEATED FRYERS 10+10 LITERS  
 FRITEUSES ELECTRIQUES 10+10 LITRES  
 ELEKTRO FRITEUSEN 10+10 LITERS

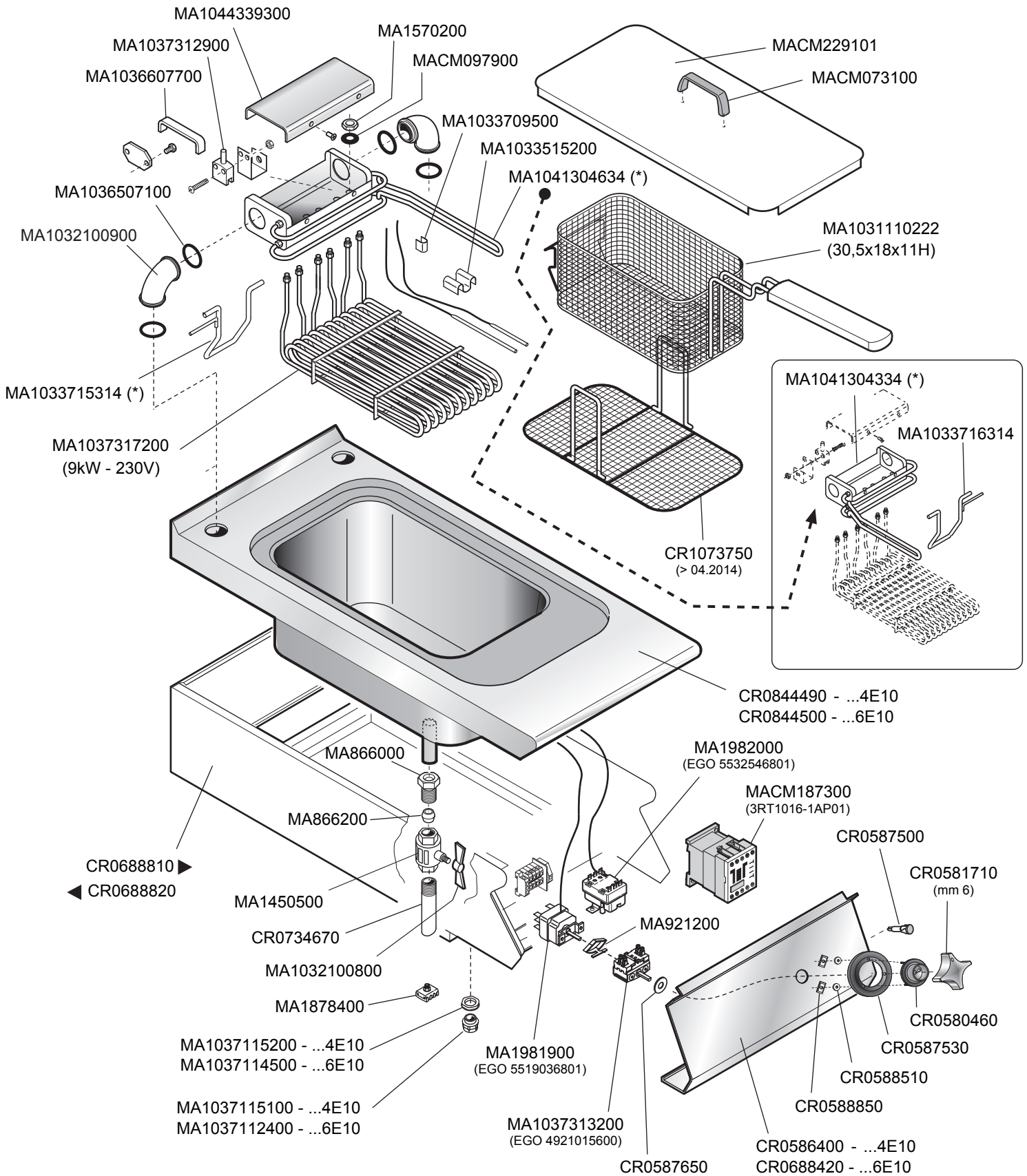

 MARENO INDUSTRIE ALI spa Mareno di Piave (TV)	ELABORATO:	APPROVATO:	GRUPPO:	DENOMINAZIONE:		
			Serie NP70 (Vasche 10 litri)	Impianto elettrico FQE41/61 e mobile		
	DATA:	DATA:	PARTICOLARE:	REV. N.	DEL	DISEGNO N.
	01 Giu 2013	01 Giu 2013	Disegno esploso per ricambi	Z01	0414	3.P70.44 1/3
SOST. DIS.						