

**NP70-10**

**Mod.**  
**NF74E10TW** CR0951850  
**NF76E10TW** CR0951860  
**NF74E10TKW** CR0851340  
**NF76E10TKW** CR0851350

**FRIGGITRICI ELETTRICHE 10+10 LITRI**  
**ELECTRIC HEATED FRYERS 10+10 LITERS**  
**FRITEUSES ELECTRIQUES 10+10 LITRES**  
**ELEKTRO FRITEUSEN 10+10 LITERS**

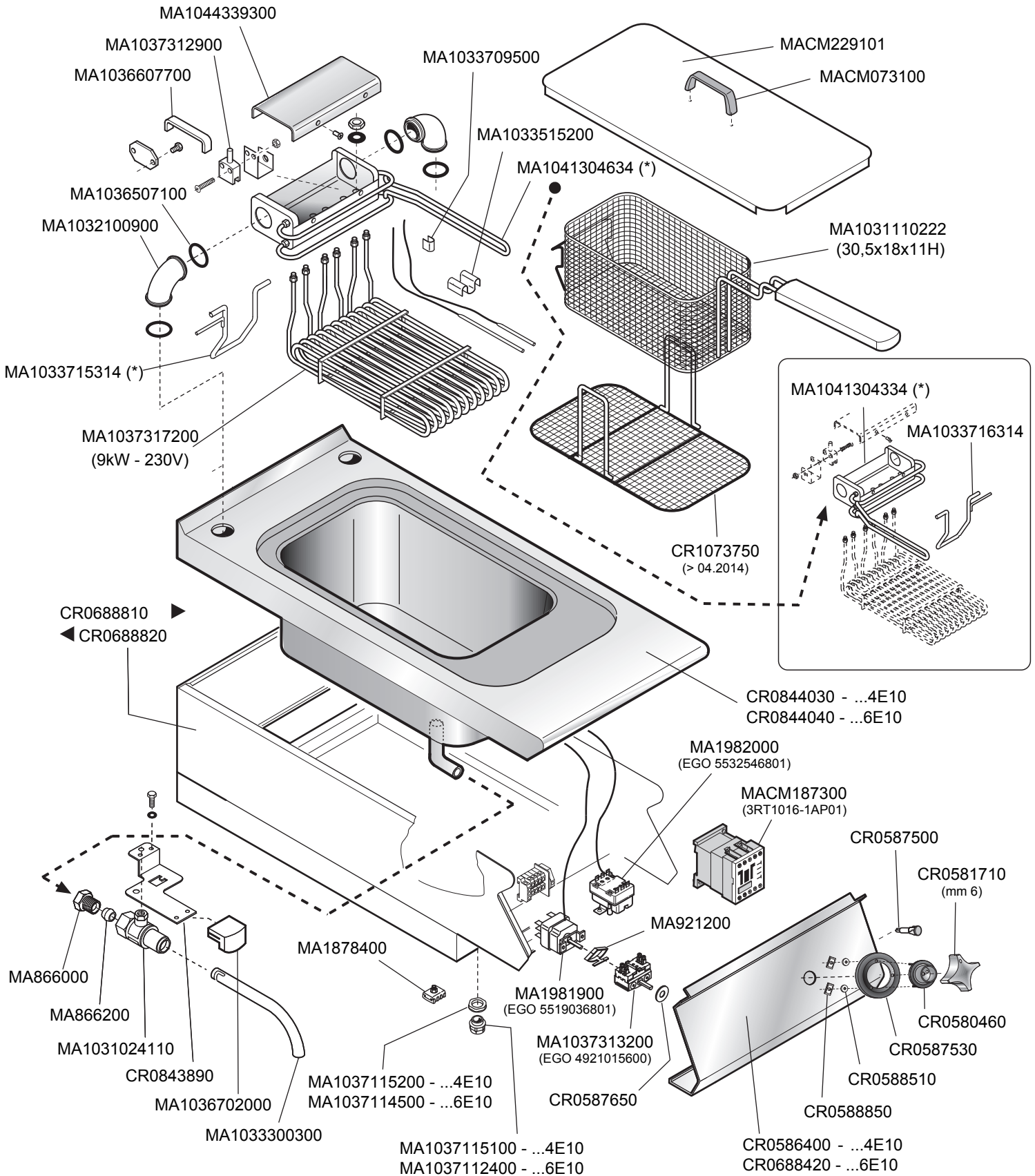

 MARENO INDUSTRIE ALI spa Mareno di Piave (TV)	ELABORATO:	APPROVATO:	GRUPPO:	DENOMINAZIONE:		
			Serie NP70 (Vasche 10 litri)	Impianto elettrico e mobile W.W.		
	DATA:	DATA:	PARTICOLARE:	REV. N.	DEL	DISEGNO N.
	01 Giu 2013	01 Giu 2013	Disegno esploso per ricambi	Z01	0414	3.P70W.44 2/3
SOST. DIS.						

NP70-10

Mod.  
**NF74E10TK** CR0851220  
**NF76E10TK** CR0851230  
**NF74E10TKW** CR0851340  
**NF76E10TKW** CR0851350

FRIGGITRICI A COMANDO ELETTRONICO 10+10 LITRI  
 ELECTRONIC CONTROL FRYERS 10+10 LITERS  
 FRITEUSES ELECTRONIQUES 10+10 LITRES  
 ELEKTRO FRITEUSEN 10+10 LITERS

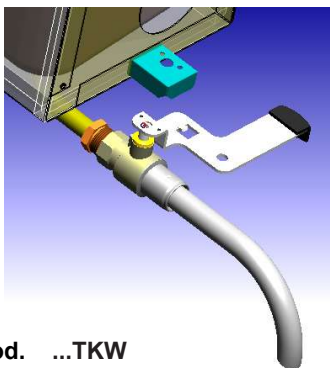
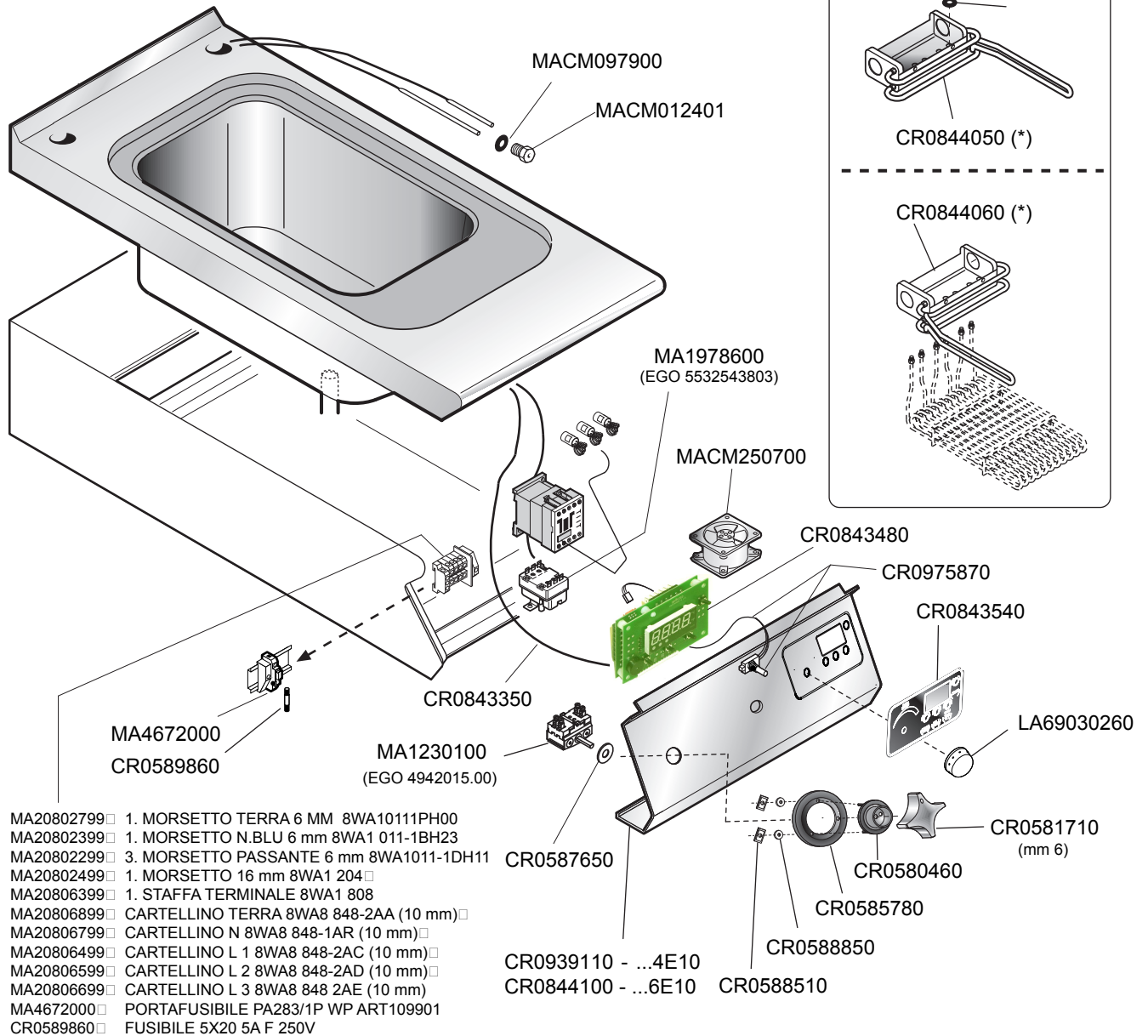

Mod. ...TKW

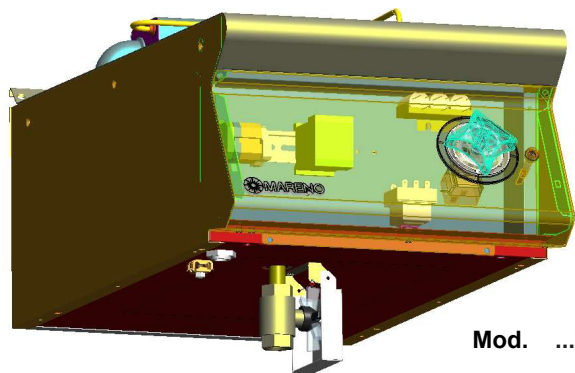

Mod. ...TK

 MARENO INDUSTRIE ALI spa Mareno di Piave (TV)	ELABORATO:	APPROVATO:	GRUPPO:	DENOMINAZIONE:		
			Serie NP70 (Vasche 10 litri)	Impianto elettrico e controllo digitale		
	DATA:	DATA:	PARTICOLARE:	REV. N.	DEL	Disegno N.
	01 Giu 2013	01 Giu 2013	Disegno esploso per ricambi	Z01	0414	3.P70K.44 3/3
SOST. DIS.						