

NP90-07

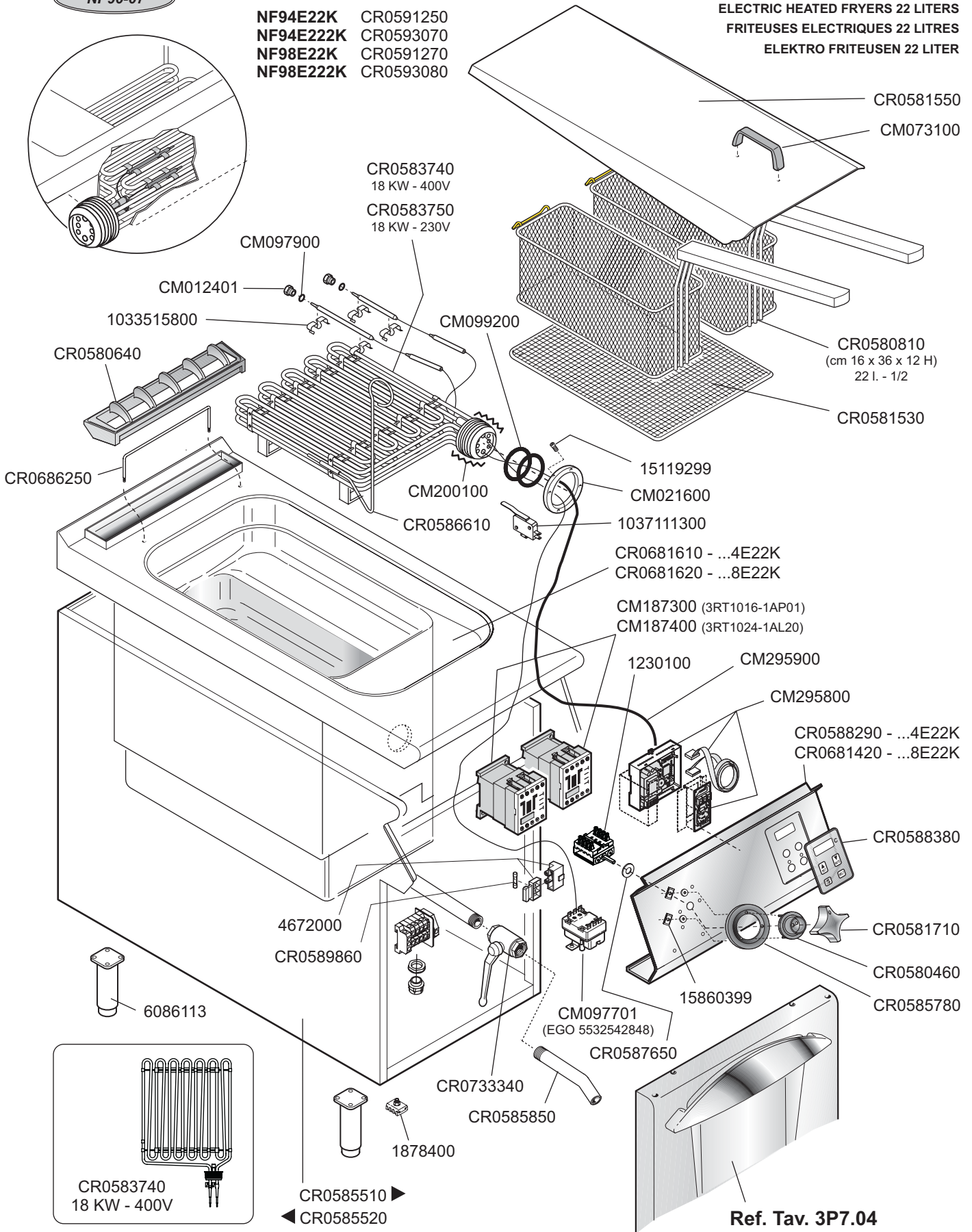

MOD.

NF94E22K CR0591250
 NF94E222K CR0593070
 NF98E22K CR0591270
 NF98E222K CR0593080

FRIGGITRICI ELETTRICHE 22 LITRI DIGITALI
 ELECTRIC HEATED FRYERS 22 LITERS
 FRITEUSES ELECTRIQUES 22 LITRES
 ELEKTRO FRITEUSEN 22 LITER



Ref. Tav. 3P7.04

 MARENO INDUSTRIE ALI spa Mareno di Piave (TV)	ELABORATO:	APPROVATO:	GRUPPO:	DENOMINAZIONE:		
			Serie NP90 (Vasche 22 litri)	Impianto elettrico e mobile		
	DATA:	DATA:	PARTICOLARE:	REV. N.	DEL	DISEGNO N.
	29 Ago 2007	29 Ago 2007	Disegno esploso per ricambi 	▼ 200	▼ 0710	▼ 3.P907.33
SOST. DIS.						