

SERIE 1100
EFET2110

FRIGGITRICI ELETTRICHE - 10 LITRI
ELECTRIC HEATED FRYERS - 10 LITERS
FRITEUSES ELECTRIQUES - 10 LITRES
ELEKTROBEHEIZTE FRITUSEN - 10 LITERS

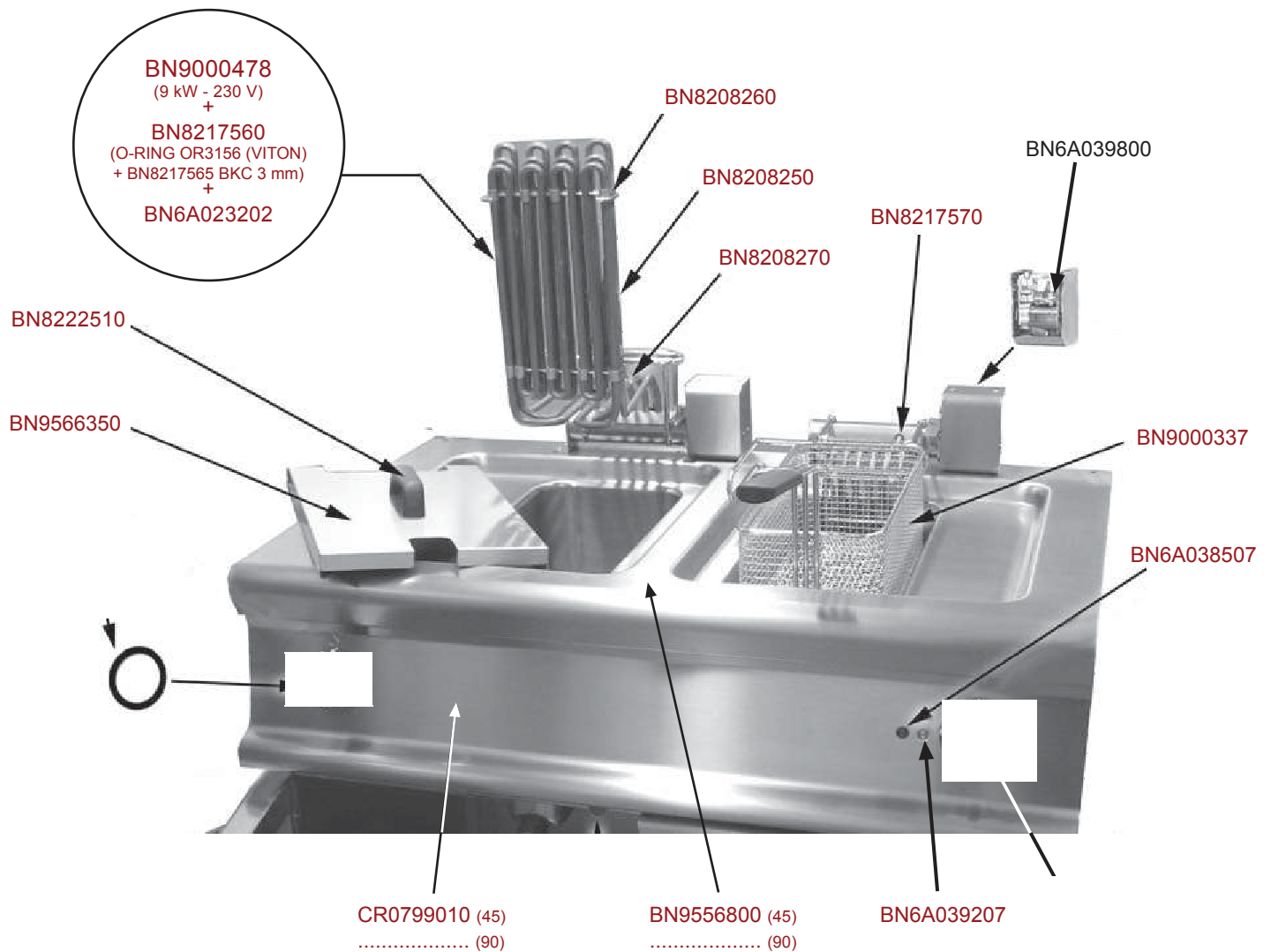

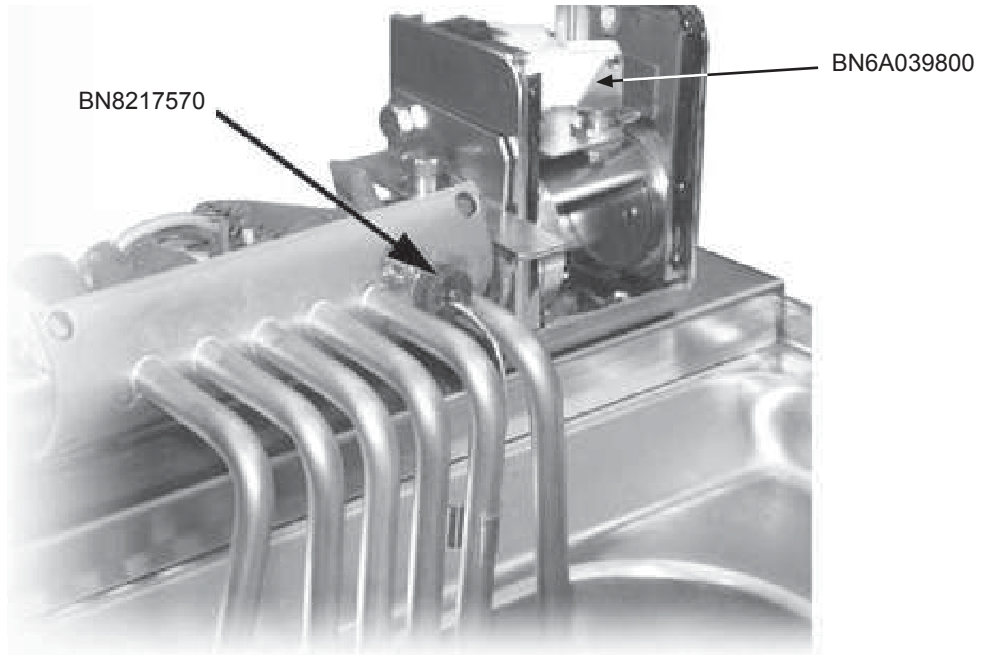
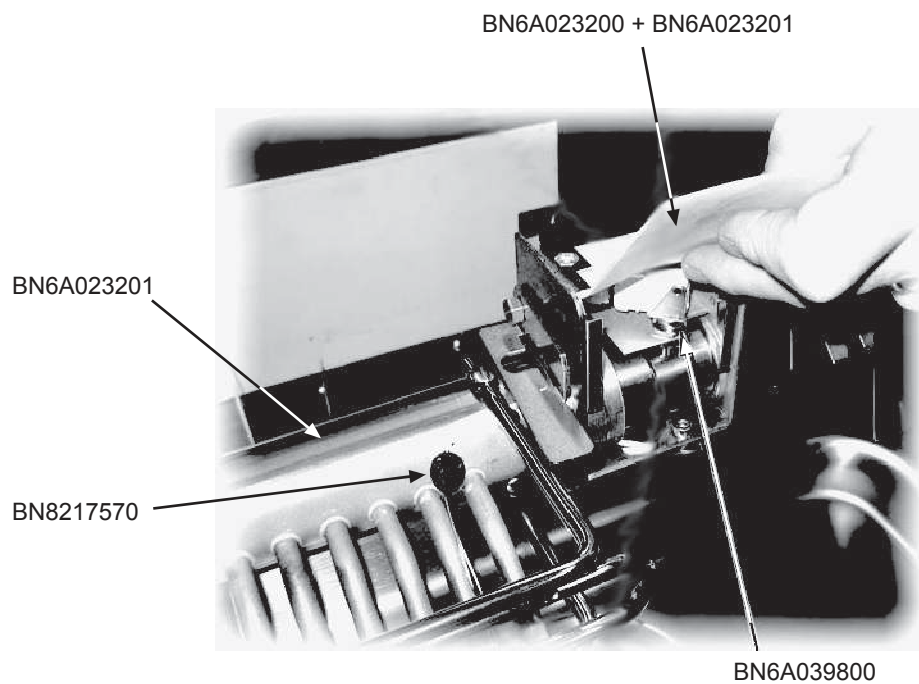

FRIGGITRICI ELETTRICHE - 10 LITRI
ELECTRIC HEATED FRYERS - 10 LITERS
FRITEUSES ELECTRIQUES - 10 LITRES
ELEKTROBEHEIZTE FRITEUSEN - 10 LITERS

BN8219602
(EGO 5532545800)
+
BN8219600

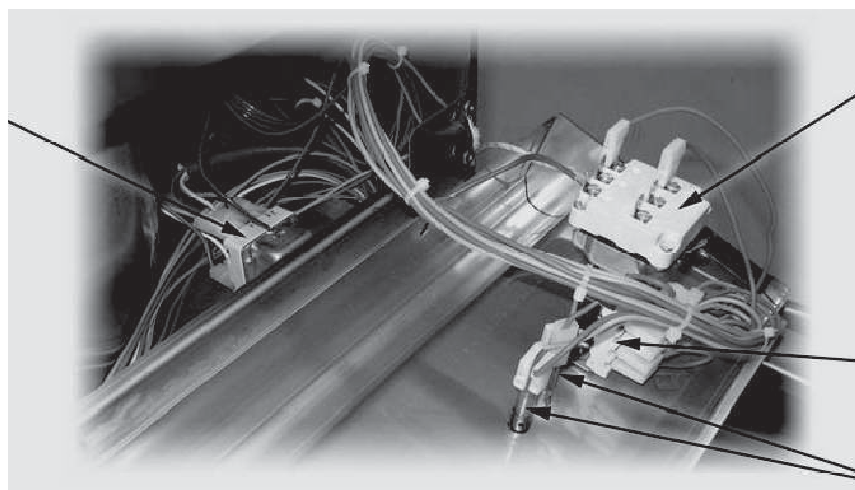

BN8219601
(EGO 5534039800)
+
MA1988500

MA1037313200
(EGO 4921015600)
250V 6A

BN6A038506

BN9000390



FRIGGITRICI ELETTRICHE - 10 LITRI
 ELECTRIC HEATED FRYERS - 10 LITERS
 FRITEUSES ELECTRIQUES - 10 LITRES
 ELEKTROBEHEIZTE FRITUSEN - 10 LITERS

