

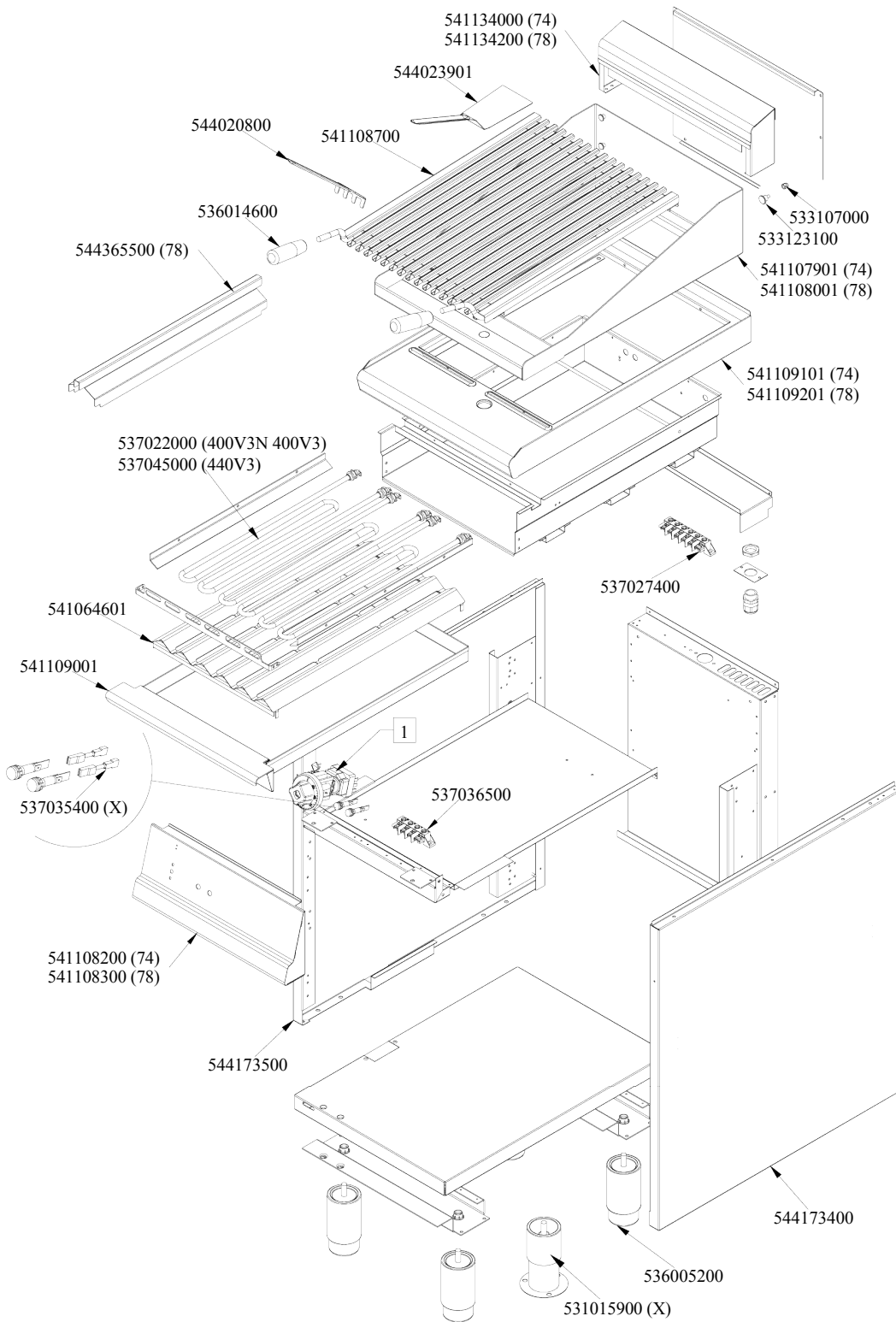

CW-78ET (SN>=1201<=1604)
Tav. 560011101M02P00





CW-78ET (SN>=1201<=1604) - CUOCI WURSTEL CW-78ET

Codice	Descrizione
544365500	TEGOLO CENTRALE PARASPR.CW-78
541134200	ASS.DIST.S70 BASS.7 8 0 NEUTRO
541108001	ASS.PARASP.CW-78
541109201	ASS.PIANO S70 CW-78G/E VEDI 544
537027400	MORSETT.6 POLI 40A VITE-VITE
544023901	PALETTA FRY-TOP
544020800	RASCHIETTO GRIGLIA CW S70/90
536014600	IMPUGNAT.Ø28X90XM10 CW
541064601	ASS.RIFLETTENTE CW-74E
541109001	ASS.CASS.RACC.SUGO CW-74E
541108700	ASS.GRIGLIA CW-74 TEGOLO S
541108300	ASS.CRUSC.S607090 CW-78/98E
544173500	FIANCO APP.S70M SX
544173400	FIANCO APP.S70M DX
536005200	PIEDE Ø2" 120-180 M10 INOX
537036500	MORSETT.4 POLI 40A VITE-VITE
537022000	RES.COR.CW S70 2000W 1-230V
533123100	CODICE IN ELABORAZIONE
533107000	CODICE IN ELABORAZIONE
-	-



COMANDO CW-E FT-E BRF-E (SN<=1604)
Tav. 560100400M00P00

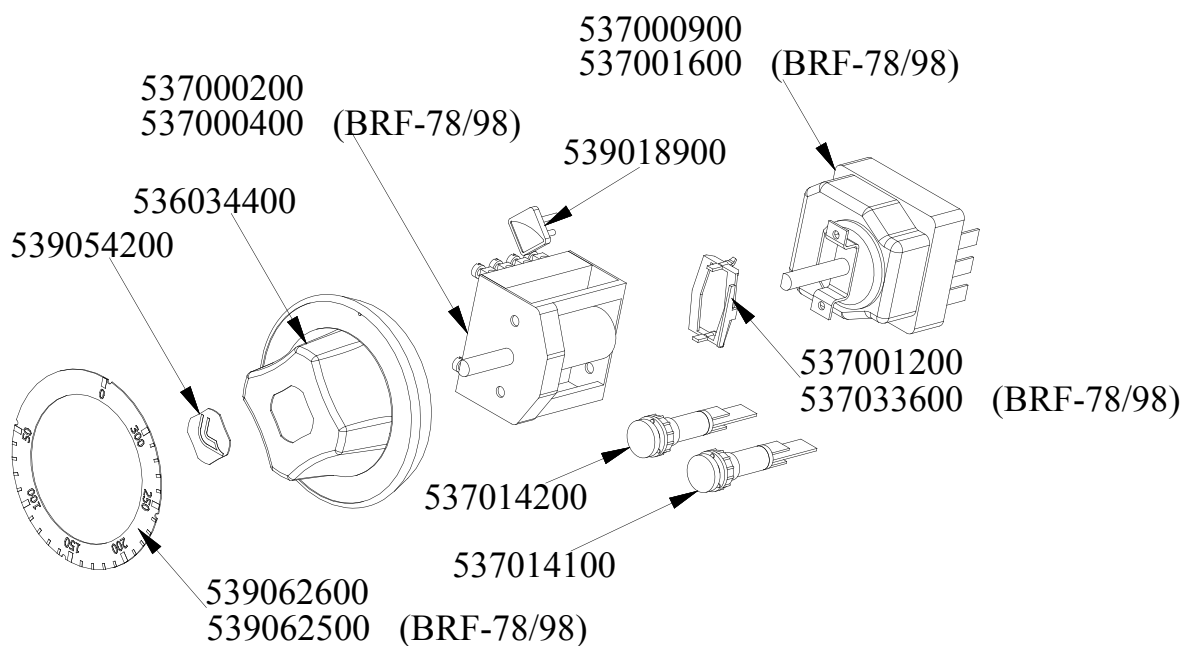

560100400 M00P00



COMANDO CW-E FT-E BRF-E (SN<=1604) - COMPONENTI COMUNI COMANDO_BRF-E

Codice	Descrizione
537000900	TERMOST.F.TRIF. 063-320°C GAMB.L
537001600	TERMOST.F.MONOF.055-320°C GAMB.L
537000200	COMM.1 POS.3F 16A
537000400	COMM.1 POS.1F 16A
539018900	INDICE MAN.C/FRECCIA ROSSA
536034400	MANOP.Ø77 4 P.Ø06X4,6 NERO C/M
539054200	BOLLINO Ø20,3 CR."L" LOTUS R.
537001200	STAFF.FISS.COMM.S49 TERMOST.3,5
537033600	STAFF.FISS.COMM.S49 TERMOST.8,5
537014200	SPIA G.B.VERDE 250VAC F.M.
537014100	SPIA G.B.BIANC.250VAC F.M.
539062600	DISC.72.FT-ET R. (050,300°)
539062500	DISC.72.FT-EM R. (050,300°)