

**Ersatzteilliste
Liste pieces de rechange
Liste dei pezzi di ricambio
Spare part list**

**BRAT-, BACK-, PATISSERIE SCHRÄNKE
FOURS A RÔTIR, A CUIRE ET A PATISSERIE
FORNI COMPONENTI PER COTTURA E PASTICCERIA
ROASTING, BAKING AND PASTRY OVENS**

BE

D	F	I	GB		
Baugruppe:	Unité:	Unità:	Unit:	Introduction	No.
Gerät BE 2W-C	appareil BE 2W-C	apparecchio BE 2W-C	appliance BE 2W-C	12.83	72.0821.01
Gerät BE 2A-C	appareil BE 2A-C	apparecchio BE 2A-C	appliance BE 2A-C	12.83	72.0821.03
Backofen	four	forno	baking oven	04.95	72.0821.05
Backofentüre	porte du four	porta del forno	baking oven door	04.95	72.0821.07
Reglerblende	bandeau de commande	pannello di comando	control panel BO	04.95	72.0821.09
Reglerblende	bandeau de commande	pannello di comando	control panel WS	04.95	72.0821.10
Wärmeschrank	armoire chauffante	armadio riscaldante	hot cupboard	04.95	72.0821.11
Abstellraum	compartiment de rangement.	spazio aperto	open compartment	04.95	72.0821.13
Schild	plaquette	placchetta	label	10.00	72.0821.20

72.0821.01
12.83

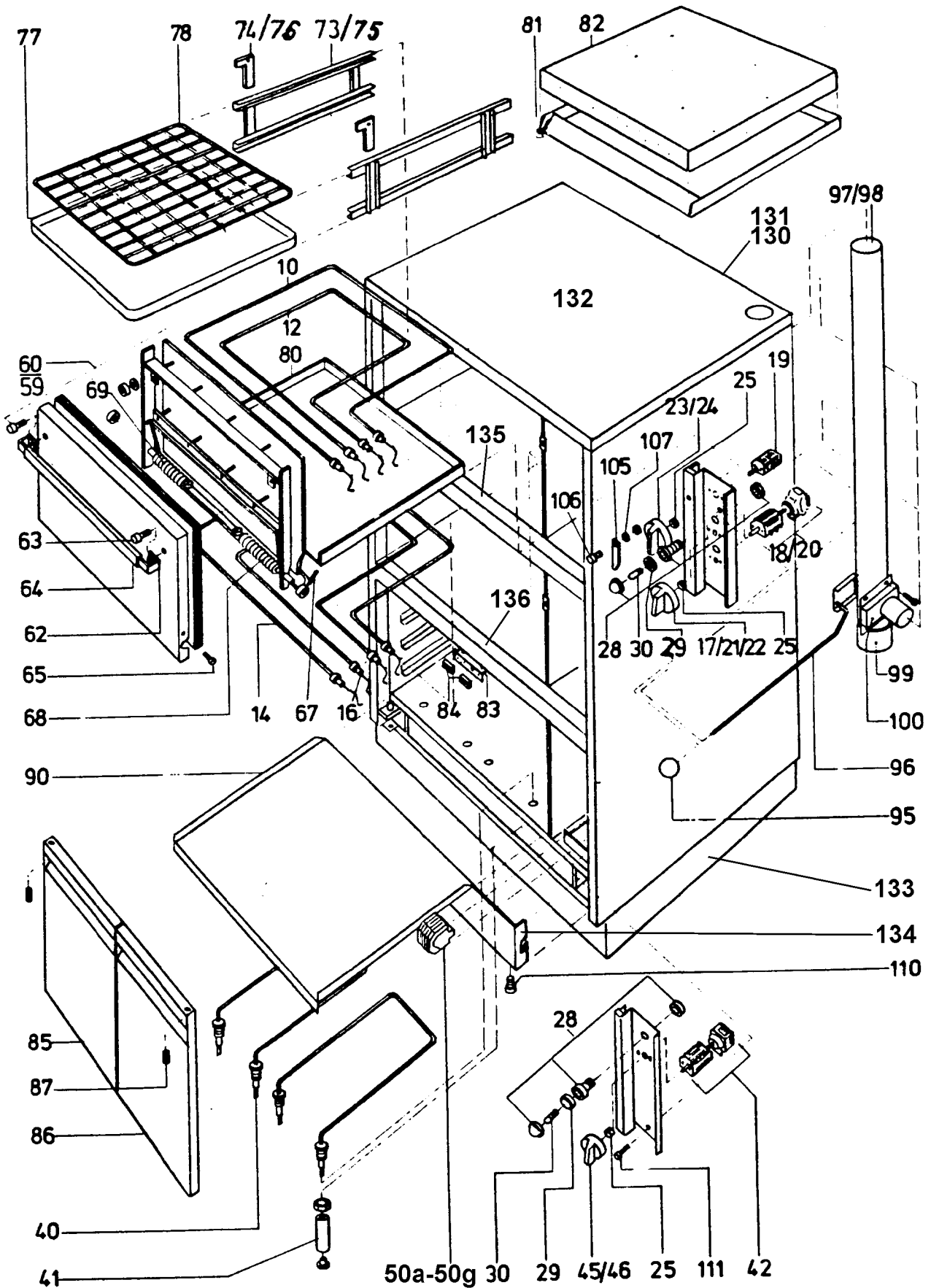

Doc. No.	Issue	DE	FR	IT	GB	Seite/ Page/ Pagina/ Page
72.0821.01	09.98	Baugruppe	Unité	Unità	Unit	1
		Gerät BE 2W-C	Appareil BE 2W-C	Apparecchio BE 2W-C	Appliance BE 2W-C	

Pos.	Product No.	Service No.	Bezeichnung	Désignation	Designazione	Designation		BO	WS	Intro- duction
10	719 020 102		Heizkörper	élément de chauffe	elemento riscaldante	heating element	230V	1		12.83
	719 020 094	1800 1820	Heizkörper	élément de chauffe	elemento riscaldante	heating element	400V	1		12.83
	719 020 098		Heizkörper	élément de chauffe	elemento riscaldante	heating element	440V	1		12.83
12	719 020 096		Heizkörper	élément de chauffe	elemento riscaldante	heating element	230V	1		12.83
	719 020 100	1800 1825	Heizkörper	élément de chauffe	elemento riscaldante	heating element	400V	1		12.83
	719 020 104		Heizkörper	élément de chauffe	elemento riscaldante	heating element	440V	1		12.83
14	719 020 107		Heizkörper	élément de chauffe	elemento riscaldante	heating element	230V	1		12.83
	719 020 095	1800 1821	Heizkörper	élément de chauffe	elemento riscaldante	heating element	400V	1		12.83
	719 020 099		Heizkörper	élément de chauffe	elemento riscaldante	heating element	440V	1		12.83
16	719 020 097		Heizkörper	élément de chauffe	elemento riscaldante	heating element	230V	1		12.83
	719 020 106	1800 1824	Heizkörper	élément de chauffe	elemento riscaldante	heating element	400V	1		12.83
	719 020 108		Heizkörper	élément de chauffe	elemento riscaldante	heating element	440V	1		12.83
17	712 344 766	1901 6031	Reglergriff	poignée du régulateur	manetta del regolatore	regulator knob	350°C	2		3.85
18	712 844 014	1801 5456	Regler	régulateur	regolatore	regulator	350°C	2		3.85
19	712 344 150	1800 5014	Schalter	interrupteur	interruttore	switch		2		12.83
20	712 844 009	1801 5428	Regler	régulateur	regolatore	regulator	300°C	1		12.83
21	712 344 748	1900 6035	Reglergriff schwarz	poignée du régulateur noir	manetta del regolatore nero	regulator knob black	300°C	2		12.83
22			Reglergriff grau	poignée du régulateur gris	manetta del regolatore grigio	regulator knob grey	300°C	2		12.83
23	712 344 749	1900 6039	Griff schwarz	poignée noir	manetta nero	knob black		1		12.83
24	712 344 757	1901 6036	Griff grau	poignée gris	manetta grigio	knob grey		1		12.83
25	712 344 728	1901 6029	Feder	ressort	molla	spring		3		12.83
28	712 340 079	1800 3952	Lampenfassung	douille de lampe	supporto d. lampada	lamp socket		2		12.83
29	712 044 491	1900 6541	Dichtung	joint	guarnizione	sealing		2		12.83
30		1800 3900	Lampe	lampe	lampada	lamp	230V	2		12.83
		1800 3901	Lampe	lampe	lampada	lamp	400V	2		12.83

BO	Backofen	four	forno	baking oven
WS	Wärmeschrank	armoire chauffante	armadio riscaldante	hot cupboard

Doc. No.	Issue	DE	FR	IT	GB	Seite/ Page/ Pagina/ Page
72.0821.01	09.98	Baugruppe	Unité	Unità	Unit	2
		Gerät BE 2W-C	Appareil BE 2W-C	Apparecchio BE 2W-C	Appliance BE 2W-C	

Pos.	Product No.	Service No.	Bezeichnung	Désignation	Designazione	Designation		BO	WS	Intro- duction
40	719 020 035	1800 1776	Heizkörper	élément de chauffe	elemento riscaldante	heating element	400V		2	12.83
	719 020 077		Heizkörper	élément de chauffe	elemento riscaldante	heating element	440V		2	12.83
41	705 040 283	1800 2208	Schutzhülse	douille de protection	manicotto di protezione	protection sleeve			4	12.83
42	712 844 006	1801 5427	Regler	régulateur	regolatore	regulator	110°C		1	12.83
45	712 344 747	1900 6034	Reglergriff schwarz	poignée du régulateur noir	manetta del regolatore nero	regulator knob black			1	12.83
46	712 344 751	1900 6036	Reglergriff grau	poignée du régulateur gris	manetta del regolatore grigio	regulator knob grey			1	12.83
50	712 044 623	1800 0529	Anschlussklemme	borne de raccordement	morsa di contatto	connection terminal		1	1	12.83
50a	705 830 300		Klemmenhalter	support de bornes	supporto di morsa	terminal support		1	1	12.83
50b	75.2010.41		Nulleiterklemme	borne du fil neutre	morsa di terra	earth terminal		1	1	12.83
50c	75.2011.03		Schutzleiterklemme	borne de protection	morsa di protezione	protection terminal		1	1	12.83
50d	75.2010.40		Reihenklemme	barette à bornes	morsa	phase terminal		3	3	12.83
50e	75.2013		Arretierstück	pièce d'arrête	parte d'arresto	stopper part		1	1	12.83
50f	705 840 171		Erdungskabel	câble de mise à terre	cavo di terra	earth cable		1	1	12.83
50g	72.1426		Schutzblech	tôle de protection	lamiera di protezione	protection sheet		1	1	12.83
59	719 810 081		Backofentüre	porte du four	porta del forno	baking oven door		1		3.85
60	719 810 050		Backofentüre	porte du four	porta del forno	baking oven door		1		12.83
62	191 930	1900 6199	Griffhalter	fixation de poignée	supporto della manetta	knob support		2		12.83
63	054 253	1900 0741	Schraube	vis	vite	screw		2		12.83
64	704 044 287	1901 6114	Türgriff	poignée de porte	manetta della porta	door handle		1		12.83
65	1101 8605		Schraube	vis	vite	screw		2		12.83
67	103 236	1900 0365	Zylinderstift	goupille cylindrique	pignone cilindrico	cylindric bolt		2		12.83
68	719 040 139	1900 1767	Türfeder rechts	ressort de porte droit	molla della porta destra	door spring right		1		12.83
69	719 040 138	1900 1766	Türfeder links	ressort de porte gauche	molla della porta sinistra	door spring left		1		12.83
73	719 830 034	1900 9224	Rostführung	guide de grille	guida per gratella	grid guide		2		3.85
74	719 040 164	1900 9225	Arretierung	arrêt	arresto	stopper		2		3.85
75	719 830 034	1900 9224	Rostführung	guide de grille	guida per gratella	grid guide		2		12.83
76	719 040 164	1900 9225	Arretierung	arrêt	arresto	stopper		2		12.83
77	193 425	1900 1106	Kuchenblech	plaque à gâteau	pasticciera	baking sheet		X		12.83

Doc. No.	Issue	DE	FR	IT	GB	Seite/ Page/ Pagina/ Page
72.0821.01	09.98	Baugruppe	Unité	Unità	Unit	3
		Gerät BE 2W-C	Appareil BE 2W-C	Apparecchio BE 2W-C	Appliance BE 2W-C	

Pos.	Product No.	Service No.	Bezeichnung	Désignation	Designazione	Designation		BO	WS	Intro- duction
78	1110 1300	1900 1138	Rost	grille	gratella	grid		X		12.83
80	719 830 077.01		Einlegeplatte	plaque insérée	placca	plate		1		12.83
81	719 830 077.02		Einlegeplatte für Chamottplatte	plaque insérée pour plaque de chamotte	placca per placca in refrattario	plate for stone plate		1		12.83
82	719 030 110.01	1900 4601	Chamottplatte	plaque de chamotte	placca in refrattario	stone plate		1		12.83
83	705 040 364		Halter	fixation	sostegno	support			1	12.83
84	1115 1152		Magnetschnäpper	pêne magnétique	lancetta magnetica	magnetic catch			2	12.83
85	719 820 030	1900 9238	Flügeltüre links	porte à battant gauche	porta a battenti sinistra	wing door left			1	12.83
86	719 820 031	1900 9239	Flügeltüre rechts	porte à battant droit	porta a battenti destra	wing door right			1	12.83
87		1900 1238	Schraube	vis	vite	screw			2	12.83
90	719 820 029		Tablar	rayonnage	mensola	shelf			1	12.83
95	712 344 733.05	1900 6069	Kugelgriff	poignée à boule	manetta a pomello	ball handle		1		12.83
96	719 820 022	1900 0583	Schieber komplett	curseur complet	corsore completo	draught valve complete		1		12.83
97	719 820 021		Dampfrohr	tuyau de vapeur	tubo per vapore	steam	BE 3/2	1		12.83
98	719 830 043		Dampfrohr	tuyau de vapeur	tubo per vapore	steam	BE 1	1		12.83
99	719 840 026		Kondenstopf	pot de condenseur	vaso del condensatore	condens drain		1		12.83
100	719 830 037	1900 0582	Schiebergehäuse	boîtier de curseur	base del corsore	draught valve casing		1		12.83
105	193 222		Riegel	verrou	chiavistello	bar		1		12.83
106	192 282		Schraube	vis	vite	screw		1		12.83
107	1701 3513		Scheibe	disque	disco	disk		1		12.83
110	1701 7542		Schraube	vis	vite	screw	4,8x22	X	X	12.83
111	1701 7539		Schraube	vis	vite	screw	4,8x22	X	X	12.83
130	719 820 023		Rückwand	paroi arrière	parete posteriore	rear panel			1	12.83
131	719 020 032		Rückwand	paroi arrière	parete posteriore	rear panel		1		12.83
132	719 020 028		Deckel	couvercle	coperchio	lid		1		12.83
133	719 820 033		Sockel	socle	zoccolo	plinth	100		1	12.83
134	72.4583		Anschlussdeckel	couvercle de raccordement	coperchio di raccordo	connection cover			1	12.83
135	719 030 081		Traverse	traverse	traversa	crosshead		1		12.83
136	719 030 088		Traverse	traverse	traversa	crosshead			1	12.83

Doc. No.	Issue	DE	FR	IT	GB	Seite/ Page/ Pagina/ Page
72.0821.01	09.98	Baugruppe	Unité	Unità	Unit	1
		Gerät BE 2A-C	Appareil BE 2A-C	Apparecchio BE 2A-C	Appliance BE 2A-C	

Pos.	Product No.	Service No.	Bezeichnung	Désignation	Designazione	Designation		BO	AR	Intro- duction
10	719 020 102		Heizkörper	élément de chauffe	elemento riscaldante	heating element	230V	1		12.83
	719 020 094	1800 1820	Heizkörper	élément de chauffe	elemento riscaldante	heating element	400V	1		12.83
	719 020 098		Heizkörper	élément de chauffe	elemento riscaldante	heating element	440V	1		12.83
12	719 020 096		Heizkörper	élément de chauffe	elemento riscaldante	heating element	230V	1		12.83
	719 020 100	1800 1825	Heizkörper	élément de chauffe	elemento riscaldante	heating element	400V	1		12.83
	719 020 104		Heizkörper	élément de chauffe	elemento riscaldante	heating element	440V	1		12.83
14	719 020 107		Heizkörper	élément de chauffe	elemento riscaldante	heating element	230V	1		12.83
	719 020 095	1800 1821	Heizkörper	élément de chauffe	elemento riscaldante	heating element	400V	1		12.83
	719 020 099		Heizkörper	élément de chauffe	elemento riscaldante	heating element	440V	1		12.83
16	719 020 097		Heizkörper	élément de chauffe	elemento riscaldante	heating element	230V	1		12.83
	719 020 106	1800 1824	Heizkörper	élément de chauffe	elemento riscaldante	heating element	400V	1		12.83
	719 020 108		Heizkörper	élément de chauffe	elemento riscaldante	heating element	440V	1		12.83
17	712 344 766	1901 6031	Reglergriff	poignée du régulateur	manetta del regolatore	regulator knob	350°C	2		3.85
18	712 844 014	1801 5456	Regler	régulateur	regolatore	regulator	350°C	2		3.85
19	712 344 150	1800 5014	Schalter	interrupteur	interruttore	switch		2		12.83
20	712 844 009	1801 5428	Regler	régulateur	regolatore	regulator	300°C	1		12.83
21	712 344 748	1900 6035	Reglergriff schwarz	poignée du régulateur noir	manetta del regolatore nero	regulator knob black	300°C	2		12.83
22			Reglergriff grau	poignée du régulateur gris	manetta del regolatore grigio	regulator knob grey	300°C	2		12.83
23	712 344 749	1900 6039	Griff schwarz	poignée noir	manetta nero	knob black		1		12.83
24	712 344 757	1901 6036	Griff grau	poignée gris	manetta grigio	knob grey		1		12.83
25	712 344 728	1901 6029	Feder	ressort	molla	spring		3		12.83
28	712 340 079	1800 3952	Lampenfassung	douille de lampe	supporto d. lampada	lamp socket		2		12.83
29	712 044 491	1900 6541	Dichtung	joint	guarnizione	sealing		2		12.83
30		1800 3900	Lampe	lampe	lampada	lamp	230V	2		12.83
		1800 3901	Lampe	lampe	lampada	lamp	400V	2		12.83

BO
AR

Backofen
Abstellraum

four
compartment de rangem.

forno
spazio aperto

baking oven
open compartment

Doc. No.	Issue	DE	FR	IT	GB	Seite/ Page/ Pagina/ Page
72.0821.01	09.98	Baugruppe	Unité	Unità	Unit	2
		Gerät BE 2A-C	Appareil BE 2A-C	Apparecchio BE 2A-C	Appliance BE 2A-C	

Pos.	Product No.	Service No.	Bezeichnung	Désignation	Designazione	Designation		BO	AR	Intro- duction
50	712 044 623	1800 0529	Anschlussklemme	borne de raccordement	morsa di contatto	connection terminal		1	1	12.83
50a	705 830 300		Klemmenhalter	support de bornes	supporto di morsa	terminal support		1	1	12.83
50b	75.2010.41		Nulleiterklemme	borne du fil neutre	morsa di terra	earth terminal		1	1	12.83
50c	75.2011.03		Schutzleiterklemme	borne de protection	morsa di protezione	protection terminal		1	1	12.83
50d	75.2010.40		Reihenklemme	barette à bornes	morsa	phase terminal		3	3	12.83
50e	75.2013		Arretierstück	piece d'arrête	parte d'arresto	stopper part		1	1	12.83
50f	705 840 171		Erdungskabel	câble de mise à terre	cavo di terra	earth cable		1	1	12.83
50g	72.1426		Schutzblech	tôle de protection	lamiera di protezione	protection sheet		1	1	12.83
59	719 810 081		Backofentüre	porte du four	porta del forno	baking oven door		1		3.85
60	719 810 050		Backofentüre	porte du four	porta del forno	baking oven door		1		12.83
62	191 930	1900 6199	Griffhalter	fixation de poignée	supporto della manetta	knob support		2		12.83
63	054 253	1900 0741	Schraube	vis	vite	screw		2		12.83
64	704 044 287	1901 6114	Türgriff	poignée de porte	manetta della porta	door handle		1		12.83
65	1101 8605		Schraube	vis	vite	screw		2		12.83
67	103 236	1900 0365	Zylinderstift	goupille cylindrique	pignone cilindrico	cylindric bolt		2		12.83
68	719 040 139	1900 1767	Türfeder rechts	ressort de porte droit	molla della porta destra	door spring right		1		12.83
69	719 040 138	1900 1766	Türfeder links	ressort de porte gauche	molla della porta sinistra	door spring left		1		12.83
73	719 830 034	1900 9224	Rostführung	guide de grille	guida per gratella	grid guide		2		3.85
74	719 040 164	1900 9225	Arretierung	arrêt	arresto	stopper		2		3.85
75	719 830 034	1900 9224	Rostführung	guide de grille	guida per gratella	grid guide		2		12.83
76	719 040 164	1900 9225	Arretierung	arrêt	arresto	stopper		2		12.83
77	193 425	1900 1106	Kuchenblech	plaque à gâteau	pasticciera	baking sheet		X		12.83
78	1110 1300	1900 1138	Rost	grille	gratella	grid		X		12.83
80	719 830 077.01		Einlegeplatte	plaque insérée	placca	plate		1		12.83
81	719 830 077.02		Einlegeplatte für Chamottplatte	plaque insérée pour plaque de chamotte	placca per placca in refrattario	plate for stone plate		1		12.83
82	719 030 110.01	1900 4601	Chamottplatte	plaque de chamotte	placca in refrattario	stone plate		1		12.83
87		1900 1238	Schraube	vis	vite	screw			2	12.83
90	719 820 029		Bodenblech	tôle de fond	lamiera del suolo	bottom plate			1	12.83
95	712 344 733.05	1900 6069	Kugelgriff	poignée à boule	manetta a pomello	ball handle		1		12.83

Doc. No.	Issue	DE	FR	IT	GB	Seite/ Page/ Pagina/ Page
72.0821.01	09.98	Baugruppe	Unité	Unità	Unit	3
		Gerät BE 2A-C	Appareil BE 2A-C	Apparecchio BE 2A-C	Appliance BE 2A-C	

Pos.	Product No.	Service No.	Bezeichnung	Désignation	Designazione	Designation		BO	AR	Intro- duction
96	719 820 022	1900 0583	Schieber komplett	curseur complet	corsore completo	draught valve complete		1		12.83
97	719 820 021		Dampfrohr	tuyau de vapeur	tubo per vapore	steam	BE 3/2	1		12.83
98	719 830 043		Dampfrohr	tuyau de vapeur	tubo per vapore	steam	BE 1	1		12.83
99	719 840 026		Kondenstopf	pot de condenseur	vaso del condensatore	condens drain		1		12.83
100	719 830 037	1900 0582	Schiebergehäuse	boîtier de curseur	base del corsore	draught valve casing		1		12.83
105	193 222		Riegel	verrou	chiavistello	bar		1		12.83
106	192 282		Schraube	vis	vite	screw		1		12.83
107	1701 3513		Scheibe	disque	disco	disk		1		12.83
110	1701 7542		Schraube	vis	vite	screw	4,8x22	X	X	12.83
111	1701 7539		Schraube	vis	vite	screw	4,8x22	X	X	12.83
130	719 820 023		Rückwand	paroi arrière	parete posteriore	rear panel			1	12.83
131	719 020 032		Rückwand	paroi arrière	parete posteriore	rear panel		1		12.83
132	719 020 028		Deckel	couvercle	coperchio	lid		1		12.83
133	719 820 033		Sockel	socle	zoccolo	plinth	100		1	12.83
134	72.4583		Anschlussdeckel	couvercle de raccordement	coperchio di raccordo	connection cover			1	12.83
135	719 030 081		Traverse	traverse	traversa	crosshead		1		12.83
136	719 030 088		Traverse	traverse	traversa	crosshead			1	12.83

Pos.	Produkt Nr.	Service Nr.	Bezeichnung	désignation	designazione	designation	Introd.	Z
			Baugruppe	unité	unità	unit	72.0821.05	
			Backofen	four,	forno	baking oven		1
			elektrisch	electrique	elettriche	electric		04.95
1	72.0801		Gehäuse	boîtier, bâti	base/involucro	housing		1
3	719 010 021		Rahmen	cadre	telaio	frame		1
4	72.0746.01		Isolation	isolation	isolazione	insulation		1
	72.0746.02		ohne Dampfrohr	sans tuyau de vapeur	senza tubo per vapore	without steam tube		
			Isolation	isolation	isolazione	insulation		1
			mit Dampfrohr	avec tuyau de vapeur	con tubo per vapore	with steam tube		
6	1201 1688		Alu-Klebeband	bande adhésive	nastro adesivo	adhesive strip		1
7	72.0744		Befestigung	fixation	lamiera	fixation		1
8	GR40186.1		Schraube	vis	vite	screw	M6x15	3
9	712 044 120.06	1101 8577	Kepsmutter	écrou	dado	capture nut	M6	2
10	719 040 247		Halter	fixation	sostegno	support		2
11	1701 2509		Schraube	vis	vite	screw	M5x12	4
12	1701 5004		Federring	anneau de ressort	anello di molla	spring ring	M5	4
12.1	719 040 166		Scheibe	disque	disco	disk	M5	4
13	72.1797.01		Heizung	chauffage	riscaldamento	heating	200V	2
	72.1797.02		Heizung	chauffage	riscaldamento	heating	230V	2
	72.1797.03	1800 1816	Heizung	chauffage	riscaldamento	heating	400V	2
	72.1797.04		Heizung	chauffage	riscaldamento	heating	415V	2
	72.1797.05		Heizung	chauffage	riscaldamento	heating	440V	2
13a	72.5282.01		Kabel, oben	câble, en haut	cavo, sopra	cable, above	01/98	1
	72.5282.02		Kabel, unten	câble, au-dessous	cavo, in basso	cable, below	01/98	1
	72.5266.01	Marine	Kabel, oben	câble, en haut	cavo, sopra	cable, above	01/98	1
	72.5266.02	Marine	Kabel, unten	câble, au-dessous	cavo, in basso	cable, below	01/98	1
14	72.1968		Träger hinten	porteur derrière	portatore dietro	girder back		4
15	72.1969		Träger vorne	porteur devant	portatore davanti	girder front		2
16	72.0545		Abstützung	support	supporto	support		1
18	719 830 077.02		Einlegeplatte	plaque insérée	placca	plate		1
19	719 030 110.01	1900 4601	Schamottplatte	plaque en chamotte	suolo con refrattario	fire clay plate		1
20	719 830 077.01		Einlegeplatte	plaque insérée	placca	plate		1
21	719 040 244	1900 9225	Arretierung	arrêt	arresto	stopper		2
22	719 830 071	1900 9223	Rostführung	guide de grille	guida di gratella	grid guide		1
23	193 425.01	1900 1106	Kuchenblech	plaque à gâteau	pasticciera	baking sheet		1
24	1110 1300	1900 1138	Rost	grille	gratella	grid		1

72.0821.07
04.95

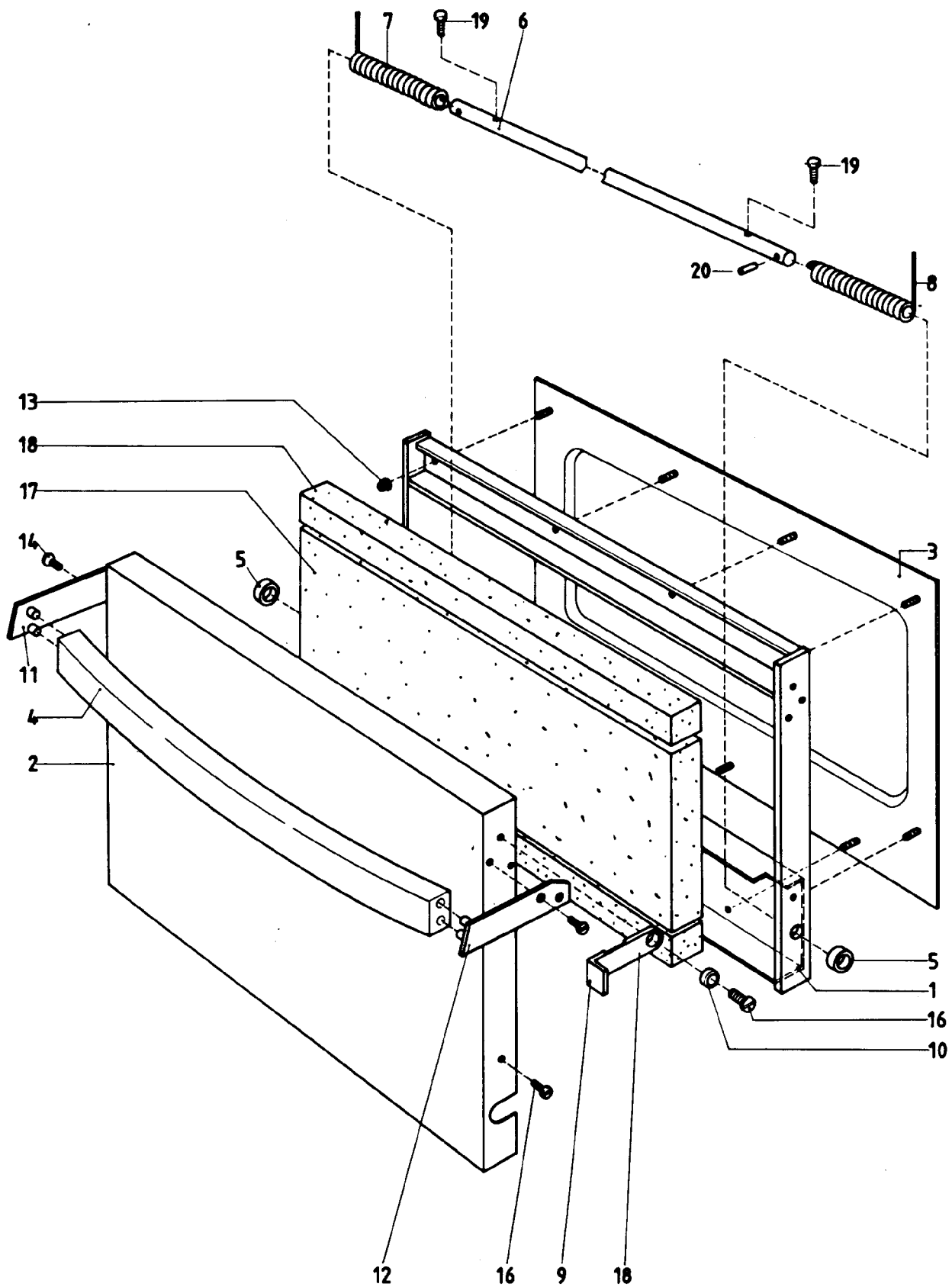

Pos.	Produkt Nr.	Service Nr.	Bezeichnung	désignation	designazione	designation	
			Baugruppe Backofentüre	unité porte du four	unità porta di forno	unit baking oven door	72.0821.07 1 04.95
	72.2709		Backofentüre komplett	porte du four complet	porta del forno completo	baking oven door complete	1
1	719 830 079		Türfüllung	remplissage de porte	empimento di porta	door filling	1
2	719 010 030		Türblech aussen	tôle de porte	lamiera di porta	door panel	1
3	719 810 080		Türblech innen	tôle de porte	lamiera di porta	door panel	1
4	72.2195	1900 6115	Stange	tige	asta	rod	1
5	719 040 197		Ring	anneau, bague	anello	ring	2
6	719 040 200		Welle	axe	albero	shaft	6
7	719 040 138	1900 1766	Feder links	ressort gauche	molla sinistra	spring left	1
8	719 040 139	1900 1767	Feder rechts	ressort droite	molla destra	spring right	1
9	719 040 262		Riegel	verrou	chiavistello	bar	1
10	719 040 263	1900 0381	Ring	anneau, bague	anello	ring	1
11	72.2824		Seitenteil links	fixation, gauche	sostegno, sinistra	support, left	1
12	72.2823		Seitenteil rechts	fixation, droite	sostegno, destra	support, right	1
13	712 044 120.06	1101 8577	Kepsmutter	écrou	dado	capture nut	16
14	1 106 1122		Schraube	vis	vite	screw	4
16	10 3179		Schraube	vis	vite	screw	3
17	719 030 159		Isolation	isolation	isolazione	insulation	1
18	719 030154		Isolation	isolation	isolazione	insulation	2
19	1701 2602		Schraube	vis	vite	screw	2
20	1701 7063		Stift	broche	spina	pivot	1

72.0821.07a
11.99

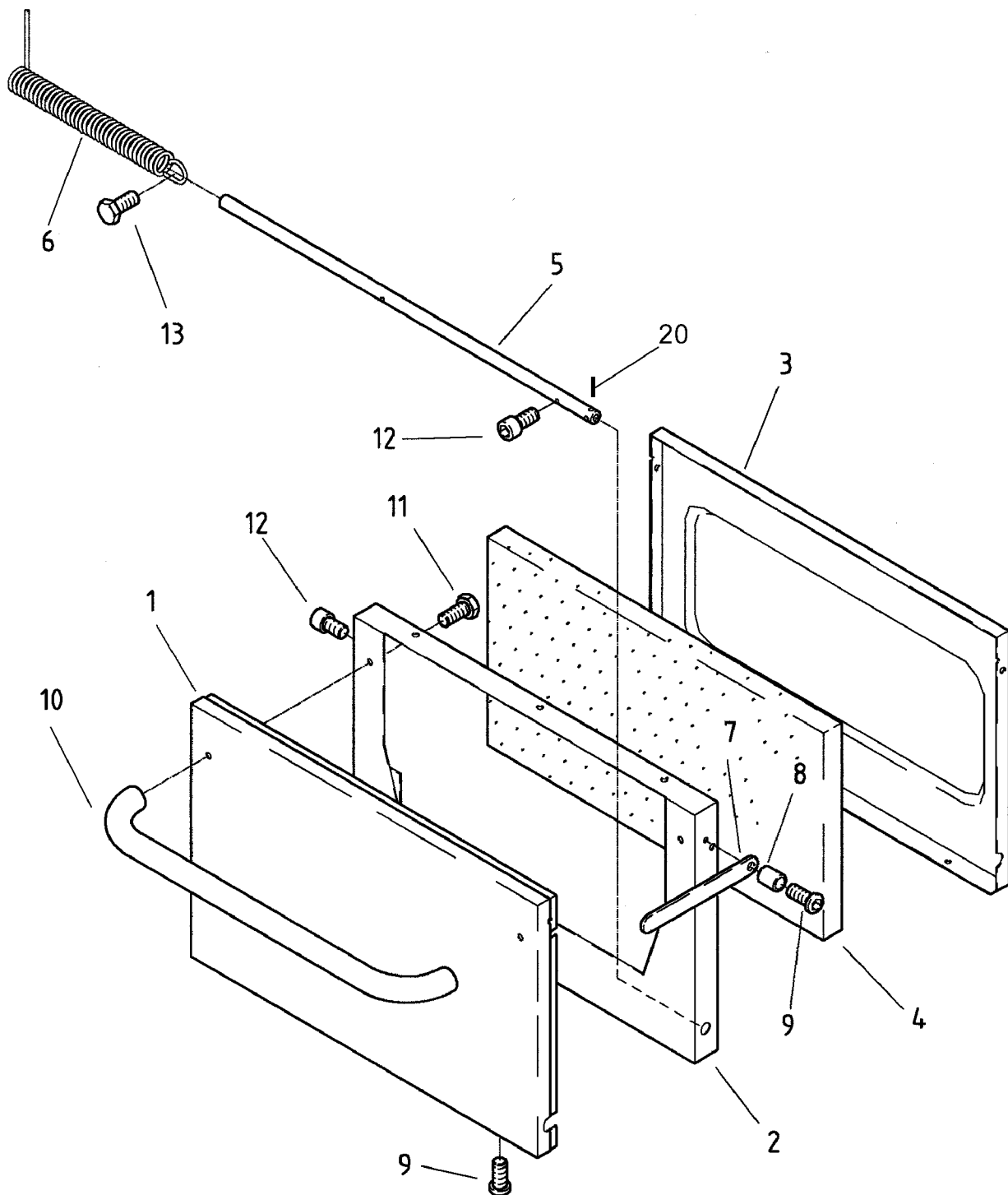

							72.0821.07a
							1
							11.99
Pos.	Produkt Nr.	Service Nr.	Bezeichnung	désignation	designazione	designation	
			Baugruppe Backofentüre	unité porte du four	unità porta di forno	unit baking oven door	
1	72.5897		Türblech aussen	tôle de porte	lamiera di porta	door panel	1
2	72.5895		Rahmen	cadre	telaio	frame	1
3	72.5898		Türblech innen	tôle de porte	lamiera di porta	door panel	1
4	72.5896		Isolation	isolation	isolazione	insulation	1
5	72.5899		Welle	axe	albero	shaft	1
6	72.5891		Feder	ressort	molla	spring	1
7	72.5958		Riegel	verrou	chiavistello	bar	1
8	72.5959		Hülse	douille	manicotto	sleeve	1
9	103179		Schraube	vis	vite	screw	4
10	72.5970		Griffstange	tige de poignée	asta della manetta	handle rod	1
11	1701 2567		Schraube	vis	vite	screw	2
12	1101 8123		Schraube	vis	vite	screw	1
13	1701 2602		Schraube	vis	vite	screw	1
20	1701 1098		Stift	broche	spina	pivot	1
1-13	72.5900		Türe komplett	porte complet	porta completo	door complete	

72.0821.09
72.0821.10
04.95

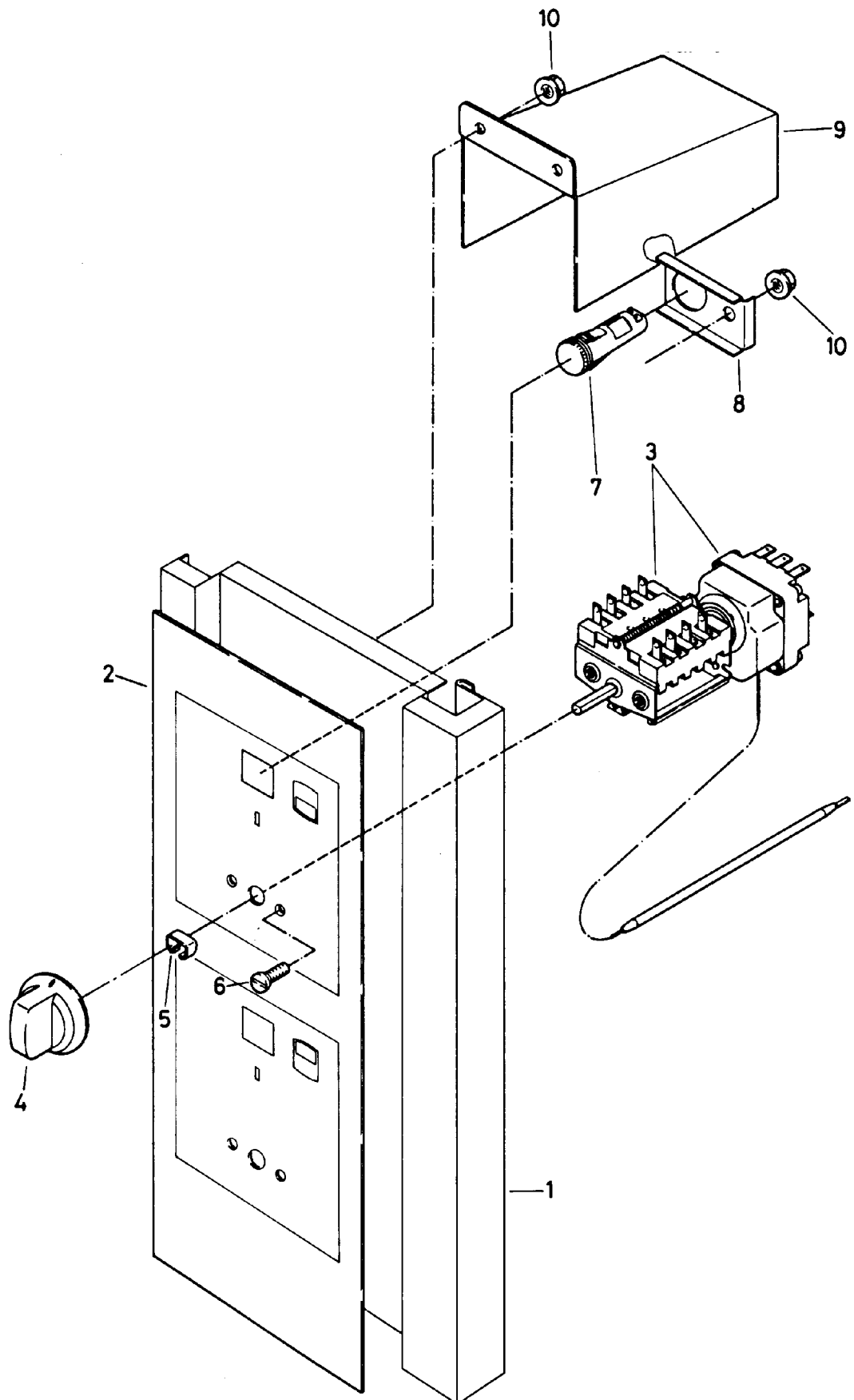

Pos.	Produkt Nr.	Service Nr.	Bezeichnung	désignation	designazione	designation	Introduction
			Baugruppe	unité	unità	unit	72.0821.09
			Reglerblende	bandeau de commande	pannello di comando	control panel	1
			Backofen	four	forno	baking oven	04.95
1	719 820 024		Reglerblende	bandeau de commande	pannello di comando	control panel	1
1a	719 030 082		Blende	bandeau	copertura	filler	1
			links	gauche	sinistra	left	
2	75.6510		Folie	film	lamiera	foil	1
	72.6370		Folie	film	lamiera	foil	1
						Electrolux	09.00
3	712 844 013	1801 5456	Regler	régulateur	regolatore	regulator	2
4	72.2259.02	1900 6116	Griff	poignée	manetta	knob	2
5	712 344 728	1901 6029	Feder	ressort	molla	spring	2
6	1701 1006		Schraube	vis	vite	screw	4
						M4x10	
7	70.0319.02		Reglerlampe	lampe de commande	lampada di comando	control lamp	2
	70.0319.10		Reglerlampe	lampe de commande	lampada di comando	control lamp	2
	70.0319.17		Reglerlampe	lampe de commande	lampada di comando	control lamp	2
						110V	
8	72.0557		Lampenhalter	fixation de lampe	sostegno di lampada	lamp support	2
9	705 040 109		Abdeckung	couvercle	copertura	cover	2
10	712 044 120.05	1101 8576	Kepsmutter	écrou	dado	capture nut	6

Pos.	Produkt Nr.	Service Nr.	Bezeichnung	désignation	designazione	designation	Introd.
			Baugruppe	unité	unità	unit	72.0821.10
			Reglerblende	bandeau de commande	pannello di comando	control panel	1
			Wärmeschrank	armoire chauffante	armadio riscaldante	hot cupboard	04.95
1	719 820 026		Reglerblende	bandeau de commande	pannello di comando	control panel	1
2	75.6505		Folie	film	lamiera	foil	1
	72.6365		Folie	film	lamiera	foil	Electrolux
3	712 844006	1 801 5427	Regler mit Vorsetzschalter	régulateur avec interrupteur amont	regolatore con interruttore aggiunto	regulator with series switch	1
4	72.2256.01		Griff	poignée	manetta	knob	1
5	712 344728	1 901 6029	Feder	ressort	molla	spring	1
6	1 701 1006		Schraube	vis	vite	screw	M4x8
7	70.0319.02		Reglerlampe	lampe de commande	lampada di comando	control lamp	200/230V
	70.0319.10		Reglerlampe	lampe de commande	lampada di comando	control lamp	400-440V
	70.0319.17		Reglerlampe	lampe de commande	lampada di comando	control lamp	110V
8	72.0557		Lampenhalter	fixation de lampe	sostegno di lampada	lamp support	1
9	705 040 109		Abdeckung	couvercle	copertura	cover	1
10	712 044120.05	1 1101 8576	Kepsmutter	écrou	dado	capture nut	3

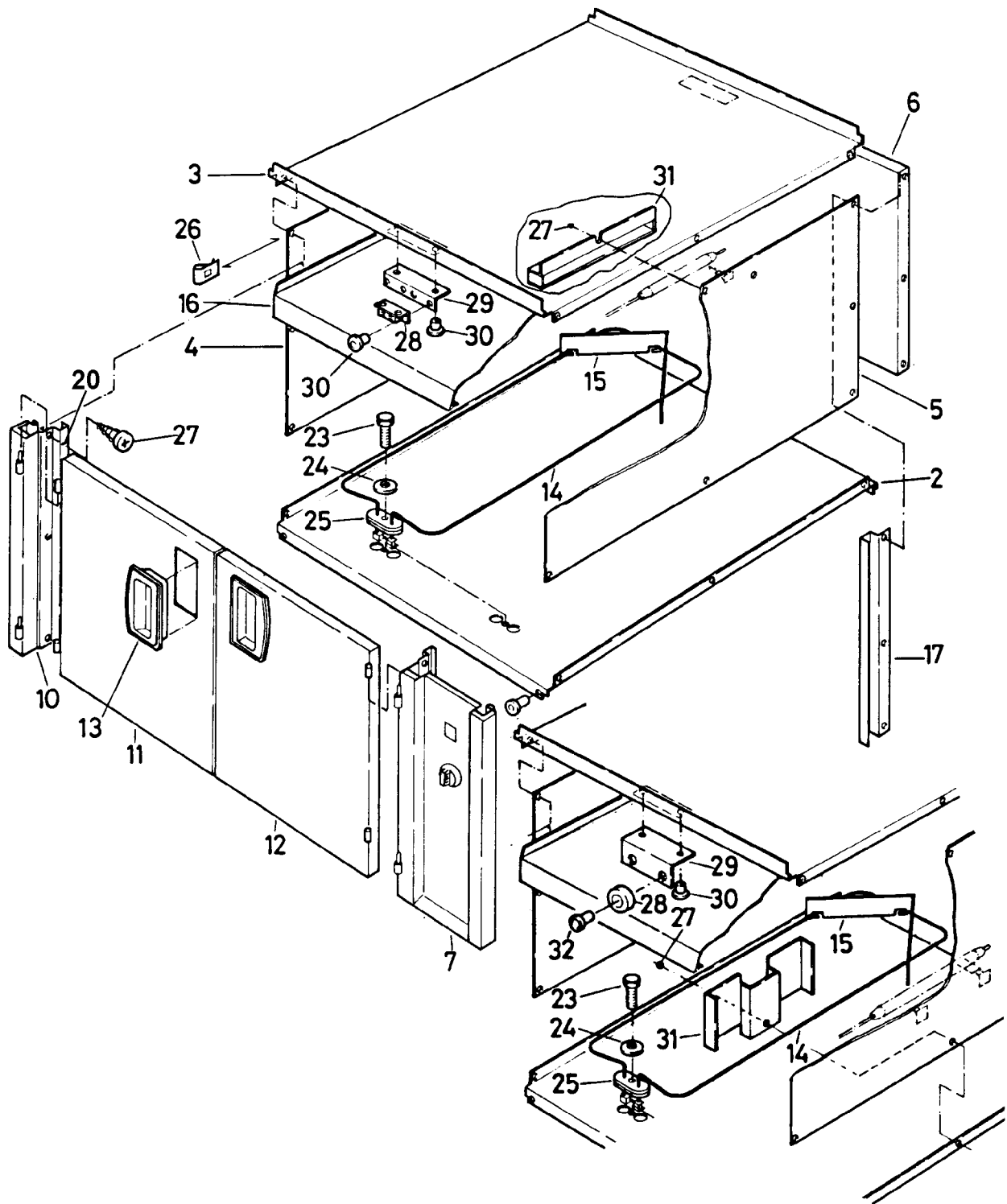

Pos.	Produkt Nr.	Service Nr.	Bezeichnung	désignation	designazione	designation	
			Baugruppe Wärmeschrank WS	unité armoire chauffante rangement AC	unità armadio riscaldante AC	unit hot ccabinet HC	72.0821.11 1 04.95
2	719 820 027		Boden	fond	fondo	base	1
3	719 820 028		Deckel	couvercle	coperchio	lid	1
4	719 830 040		Seitenwand	paroi latérale	parete laterale	side panel	1
5	719 830 039		Seitenwand	paroi latérale	parete laterale	side panel	1
6	719 020 038		Rückwand	paroi arrière	parete posteriore	rear panel	1
7	(*)		Reglerblende	bandeau de commande	pannello di comando	control panel	1
10	719 820 025		Eckpfosten links	jambage d'angle gauche	palo d'angolo sinistra	edge pole left	1
11	72.4096		Flügeltüre links	porte à battant gauche	porta a battenti sinistra	wing door left	1
12	72.4097		Flügeltüre rechts	porte à battant droit	porta a battenti destra	wing door right	1
13	72.2099	1900 6086	Griff	poignée	manetta	knob	2
14	719 020 035.05		Heizung	chauffage	riscaldamento	heating	200V 0.7kW
	719 020 035.04		Heizung	chauffage	riscaldamento	heating	230V 0.7kW
	719 020 035.03		Heizung	chauffage	riscaldamento	heating	400V 0.7kW
	719 020 035.02		Heizung	chauffage	riscaldamento	heating	415V 0.7kW
	719 020 035.01		Heizung	chauffage	riscaldamento	heating	440V 0.7kW
15	772 030 045		Halter	fixation	sostegno	support	2
16	719 820 029		Tablar	rayonnage	mensola	shelf	1
17	705 020 112		Stelleiste	litage de réglage	listello di regolazione	adjust strip	2
20	705 040 611	1900 1261	Tablarträger	support pour rayonnage	portatore di tavola	shelf support	4
23	1101 8165		Schraube	vis	vite	screw	2
24	1701 5047		Federscheibe	rondelle à ressort	disco a molla	spring disk	2
25	72.1120	1801 1709	Dichtung	joint	guarnizione	washer	2
26	1701 7538		Springmutter	écrou savonnette	dado puntellata	snap nut	16
27	1701 7541		Schraube	vis	vite	screw	16
28	1115 1152	1900 1265	Magnet	aimant	magnete	magnet	2
28a	72.7151		Magnet	aimant	magnete	magnet	09/97
29	705 040 364		Winkel	angle	angolo	angle	1
29a	72.4990		Winkel	angle	angolo	angle	09/97
30	1701 6515		Niete	rivet	rivetta	rivet	8
31	72.4138		Schutz	protection	protezione	protection	1
31a	705 020 247		Schutz	protection	protezione	protection	09/97
32	1701 1094		Niete	rivet	rivetta	rivet	09/97
		(*)	siehe 72.0821.10	voir 72.0821.10	vedere 72.0821.10	see 72.0821.10	

72.0821.13
04.95

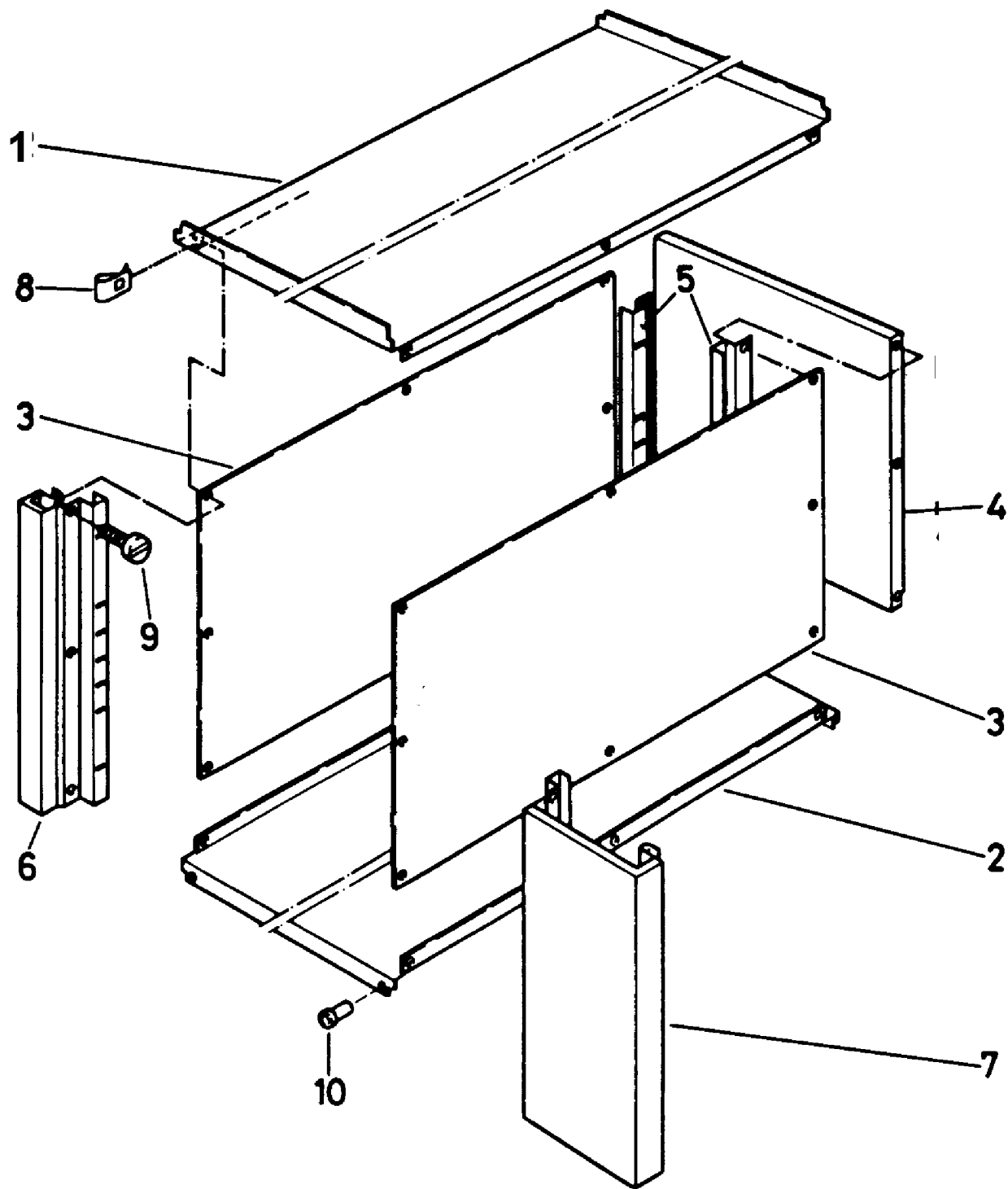

Pos.	Produkt Nr.	Service Nr.	Bezeichnung	désignation	designazione	designation	
			Baugruppe Abstellraum	unité compartiment de rangement	unità spazio aperto	unit open compartment	72.0821.13 1 04.95
1	719 020 037		Deckel	couvercle	coperchio	lid	1
2	719 020 063		Boden	fond	fondo	base	1
3	719 830 040		Seitenwand	paroi latérale	parete laterale	side panel	2
4	719 020 038		Rückwand	paroi arrière	parete posteriore	rear panel	1
5	705 020 112		Stelleiste	litéau de réglage	listello di regolazione	adjust strip	2
6	719 020 061		Eckpfosten	jambage d'angle	palo d'angolo	edge pole	1
7	719 020 062		Blende	bandeau	copertura	filler	1
8	1701 7538		Springmutter	écrou savonnette	dado puntellata	snap nut	16
9	1701 7541		Schraube	vis	vite	screw	16
10	1701 6515		Niete	rivet	rivetta	rivet	4

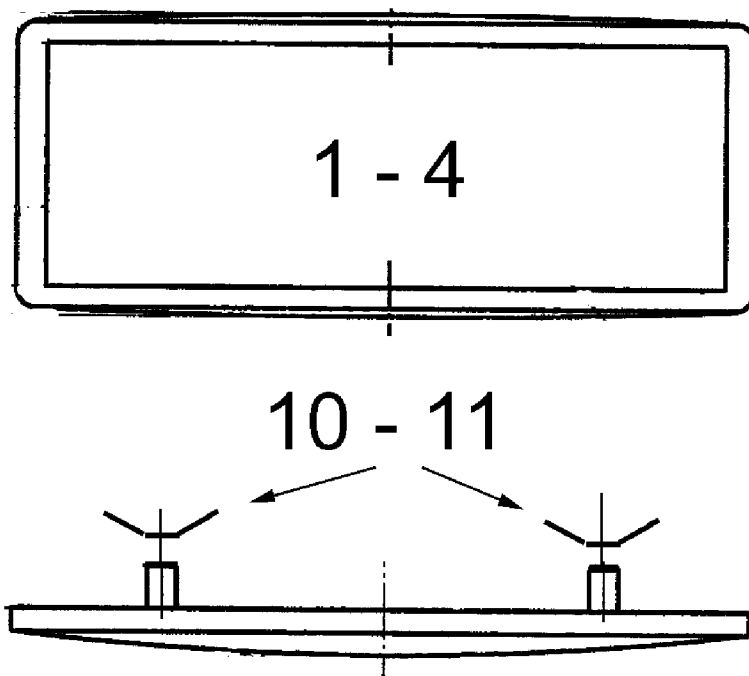

Pos.	Produkt Nr.	Service Nr.	Bezeichnung	désignation	designazione	designation		
			Baugruppe Schild	unité plaquette	unità placchetta	unit label		72.0821.20 1 10.00
1	72.2252		THERMA					1
2	72.6384		THERMALINE					1
3	76.3177		JUNOLINE					1
4	1201 2031		ELECTROLUX					1
10	1701 5072		Haltering	anneau de fixation	anello di sostegno	retaining ring	Pos. 1÷3	2
11	1201 2032		Haltering	anneau de fixation	anello di sostegno	retaining ring	Pos. 4	2